

AD9779A	Dual 16-Bit, 1 GSPS DAC
ADL5373	2300 MHz to 3000 MHz I/Q Modulator

## Interfacing the ADL5373 I/Q Modulator to the AD9779A Dual-Channel, 1 GSPS High Speed DAC

### CIRCUIT FUNCTION AND BENEFITS

This circuit provides a simple, elegant interface between the ADL5373 I/Q modulator and the AD9779A high speed DAC. The ADL5373 and the AD9779A are well-matched devices because they have the same bias levels and similarly high signal-to-noise ratios (SNR). The matched bias levels of 500 mV allow for a “glueless” interface—there is no requirement for a level shifting network that would add noise and insertion loss along with extra components. The addition of the swing-limiting resistors (RSLI, RSLQ) allows the DAC swing to be scaled appropriately without loss of resolution or of the 0.5 V bias level. The high SNR of each device preserves a high SNR through the circuit.

### CIRCUIT DESCRIPTION

The ADL5373 is designed to interface with minimal components to members of Analog Devices family of TxDAC® converters (AD97xx). The baseband inputs of the ADL5373 require a dc common-mode bias voltage of 500 mV. With each AD9779A output swinging from 0 mA to 20 mA, a single 50 Ω resistor to ground from each of the DAC outputs provides the desired 500 mV dc bias. With just the four 50 Ω resistors in place, the voltage swing on each pin is 1 V p-p. This results in a differential voltage swing of 2 V p-p on each input pair.

By adding resistors RSLI and RSLQ to the interface, the output swing of the DAC can be reduced without any loss of DAC resolution. The resistor is placed as a shunt between each side of

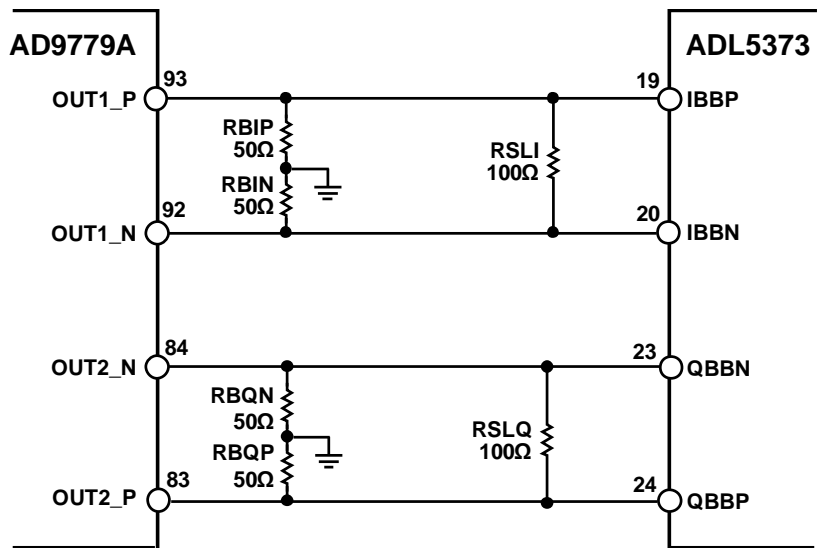

Figure 1. Interface Between the AD9779A and ADL5373 with 50 Ω Resistors to Ground to Establish the 500 mV DC Bias for the ADL5373 Baseband Inputs (Simplified Schematic)

### Rev. A

“Circuits from the Lab” from Analog Devices have been designed and built by Analog Devices engineers. Standard engineering practices have been employed in the design and construction of each circuit, and their function and performance have been tested and verified in a lab environment at room temperature. However, you are solely responsible for testing the circuit and determining its suitability and applicability for your use and application. Accordingly, in no event shall Analog Devices be liable for direct, indirect, special, incidental, consequential or punitive damages due to any cause whatsoever connected to the use of any “Circuit from the Lab”. (Continued on last page)

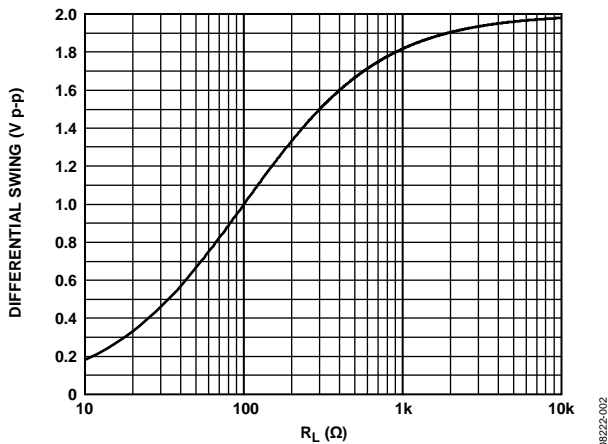

Figure 2. Relationship Between the AC Swing-Limiting Resistor and the Peak-to-Peak Voltage Swing with 50 Ω Bias-Setting Resistors

the differential pair, as shown in Figure 1. It has the effect of reducing the ac swing without changing the dc bias already established by the 50 Ω resistors and the DAC output current.

The value of this ac swing-limiting resistor is chosen based on the desired ac voltage swing. Figure 2 shows the relationship between the swing-limiting resistor and the peak-to-peak ac swing that it produces when 50 Ω bias-setting resistors are used. Note that all Analog Devices I/Q modulators present a relatively high input impedance on their baseband inputs (typically >1 kΩ). As a result, the input impedance of the I/Q modulator will have no effect on the scaling of the DAC output signal.

It is generally necessary to low-pass filter the DAC outputs to remove image frequencies when driving a modulator. The above interface lends itself well to the introduction of such a filter. The filter can be inserted between the dc bias setting resistors and the ac swing-limiting resistor. Doing so establishes the input and output impedances for the filter.

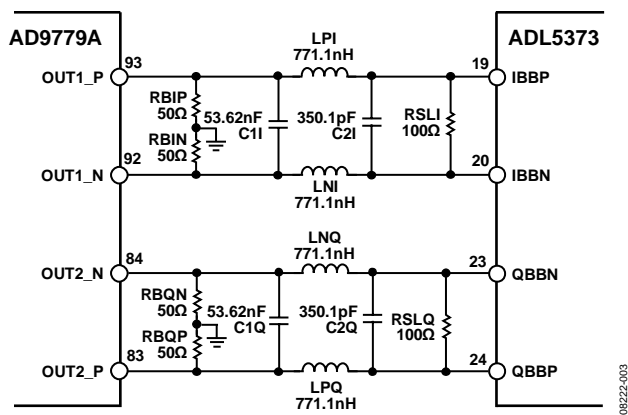

Figure 3. DAC Modulator Interface with 3 MHz Third-Order, Low-Pass Filter (Calculated Component Values)

A simulated filter example is shown in Figure 3 with a third-order elliptical filter with a 3 dB frequency of 10 MHz. Matching input and output impedances makes the filter design easier, so the shunt resistor chosen is 100 Ω, producing an ac swing of 1 V p-p differential for a 0 mA to 20 mA DAC full-scale output current. The simulated frequency response of this filter is shown in Figure 4. In a practical application, the use of standard value components along with the input impedance of the I/Q modulator (2900 kΩ in parallel with a few picofarads of input capacitance), will slightly change the frequency response.

All the power supply pins of the ADL5373 must be connected to the same 5 V source. Adjacent pins of the same name can be tied together and decoupled to a large area ground plane with a 0.1 μF capacitor. These capacitors should be located as close as possible to the device. The power supply can range between 4.75 V and 5.25 V.

The COM1 pin, COM2 pin, COM3 pin, and COM4 pin should be tied to the same ground plane through low impedance paths. The exposed paddle on the underside of the package should also be soldered to a low thermal and electrical impedance ground plane. If the ground plane spans multiple layers on the circuit board, they should be stitched together with nine vias under the exposed paddle. The AN-772 application note discusses the thermal and electrical grounding of the LFCSP\_VQ in greater detail.

**COMMON VARIATIONS**

The interface described here can be used to interface any TxDAC converter with ground referenced 0 mA to 20 mA output currents to any I/Q modulator with a 0.5 V input bias level. For zero-IF applications, the AD9783 dual DAC provides an LVDS interface, while the CMOS-driven AD9788 dual DAC can generate a fine resolution complex IF input to the I/Q modulator. The ADL5370/ADL5371/ADL5372/ADL5373/

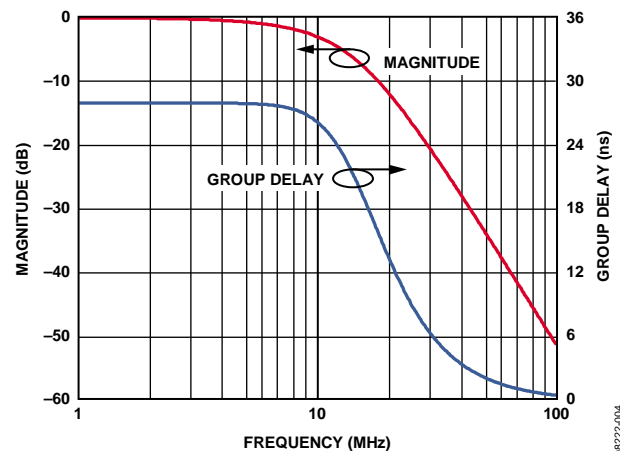

Figure 4. Simulated Frequency Response for DAC Modulator Interface with 10 MHz Third-Order Bessel Filter

ADL5374 family of I/Q modulators provides narrow-band operation with high output 1 dB compression point and OIP3, whereas the ADL5375 provides broadband high performance operation from 400 MHz to 6 GHz. The ADL5385 I/Q modulator uses a  $2 \times$  LO and operates from 50 MHz to 2.2 GHz.

## LEARN MORE

AN-772 Application Note, *A Design and Manufacturing Guide for the Lead Frame Chip Scale Package (LFCSP)*. Analog Devices.

MT-016 Tutorial, *Basic DAC Architectures III: Segmented DACs*. Analog Devices.

MT-017 Tutorial, *Oversampling Interpolating DACs*. Analog Devices.

MT-031 Tutorial, *Grounding Data Converters and Solving the Mystery of 'AGND' and 'DGND'*. Analog Devices.

MT-080 Tutorial, *Mixers and Modulators*. Analog Devices.

MT-101 Tutorial, *Decoupling Techniques*. Analog Devices.

Zumbahlen, Hank. 2006. *Basic Linear Design*. Analog Devices. ISBN 0915550281. Chapters 4 and 11. Also available as *Linear Circuit Design Handbook*. Elsevier-Newnes, 2008, ISBN 0750687037, Chapters 4 and 11.

## Data Sheets

AD9779A Data Sheet.

ADL5373 Data Sheet.

## REVISION HISTORY

5/09—Rev. 0 to Rev. A

Updated Format..... Universal

10/08—Revision 0: Initial Version

(Continued from first page) "Circuits from the Lab" are intended only for use with Analog Devices products and are the intellectual property of Analog Devices or its licensors. While you may use the "Circuits from the Lab" in the design of your product, no other license is granted by implication or otherwise under any patents or other intellectual property by application or use of the "Circuits from the Lab". Information furnished by Analog Devices is believed to be accurate and reliable. However, "Circuits from the Lab" are supplied "as is" and without warranties of any kind, express, implied, or statutory including, but not limited to, any implied warranty of merchantability, noninfringement or fitness for a particular purpose and no responsibility is assumed by Analog Devices for their use, nor for any infringements of patents or other rights of third parties that may result from their use. Analog Devices reserves the right to change any "Circuits from the Lab" at any time without notice, but is under no obligation to do so. Trademarks and registered trademarks are the property of their respective owners.