



ZPT-3528C-14-Z2

Technical Data Sheet

Top Phototransistor

Descriptions

ZPT-3528C-14-Z2 is a high speed silicon NPN epitaxial planar phototransistor in a compact surface-mountable package. It's compatible with automatic placement equipment and can withstand IR reflow, vapor phase reflow, and wave solder processes.

Features

- High radiant power and high radiant intensity.
- Lens Appearance: Water clear.
- 3.5*2.8*1.35mm standard package.
- Suitable for all SMT assembly methods.
- Compatible with infrared and vapor phase reflow solder process.
- Compatible with automatic placement equipment.
- This product doesn't contain restriction Substance, comply ROHS standard.

Applications

- Lighting
- Automotive lighting.
- Backlighting: LCDs
- Status indicators: Consumer & industrial electronics.
- General use.



Package Dimensions

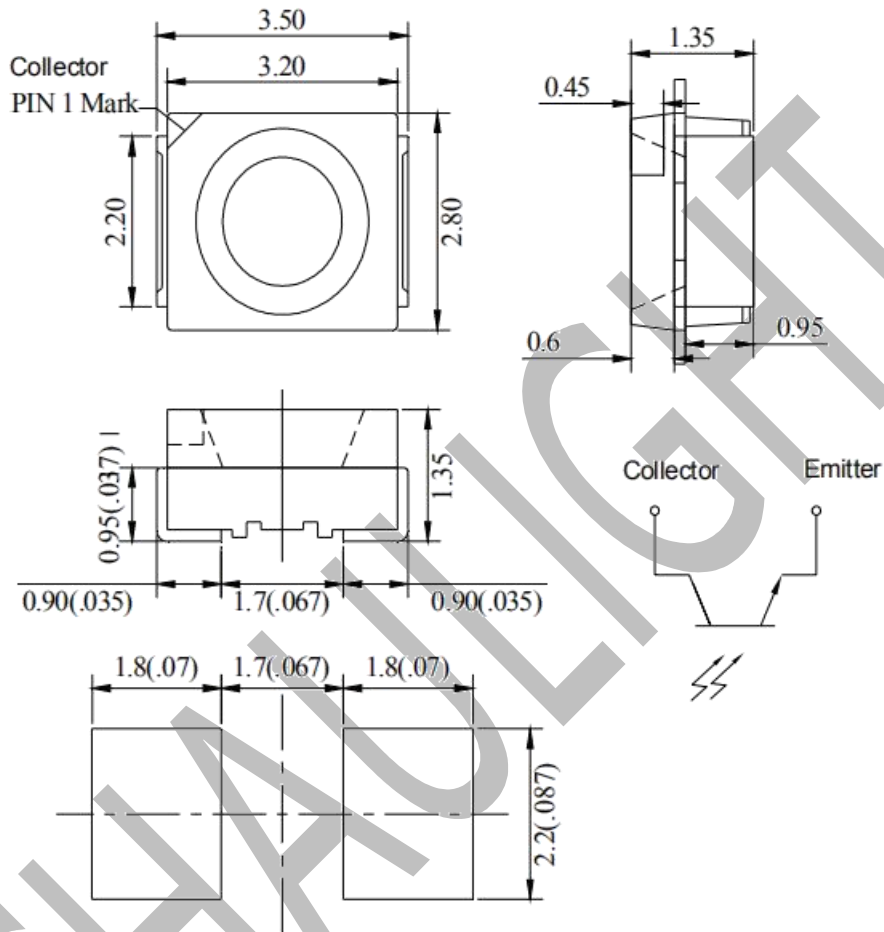

- Notes:
- 1.All dimensions are in millimeters.
 - 2.Tolerance is ± 0.10 mm unless otherwise specified.
 - 3.Specifications are subject to change without notice.



Absolute Maximum Ratings (Ta=25°C)

Parameter	Symbol	Rating	Unit
Power Dissipation	Pd	75	mW
Emitter-Collector Breakdown Voltage	BV _{CEO}	30	V
Emitter-Collector Breakdown Voltage	BV _{ECCO}	5	V
Operating Temperature	Topr	-40°C~80°C	-
Storage Temperature	Tstg	-40°C~100°C	-
Soldering Temperature	Tsol	See Page 6	-

Note : IFP is pulse of 1/10 duty at 1KHz

Electrical and optical characteristics (Ta=25°C)

Parameter	Symbol	Condition	Min.	Typ.	Max.	Unit
Spectrum Sensitivity	λ_d	I _F =50mA	500	-	1000	nm
Short Circuit Current	λ_p	I _F =50mA	-	940	-	nm
Collector Light Current	I _{C(ON)}	V _{CE} =5V, λ_p =940nm, H=1.0mw/cm ²	4.90	-	7.20	mA
Collector Dark Current	I _{CEO}	V _{CE} =20V	-	-	100	nA
Rise/Fall Time	T _r /T _f	V _{CE} =5V, I _c =1mA, R _L =1K Ω	-	15/15	-	us
Viewing Angle	2 $\theta_{1/2}$	I _F =50mA	-	120	-	deg

Rank

Condition : V_{CE}=5V, λ_p =940nm, H=1.0mw/cm²

BIN	MIN	MAX
P2	4.90	7.20

Tolerance for each Bin limit is $\pm 15\%$



Typical Electrical/Optical/Characteristics Curves

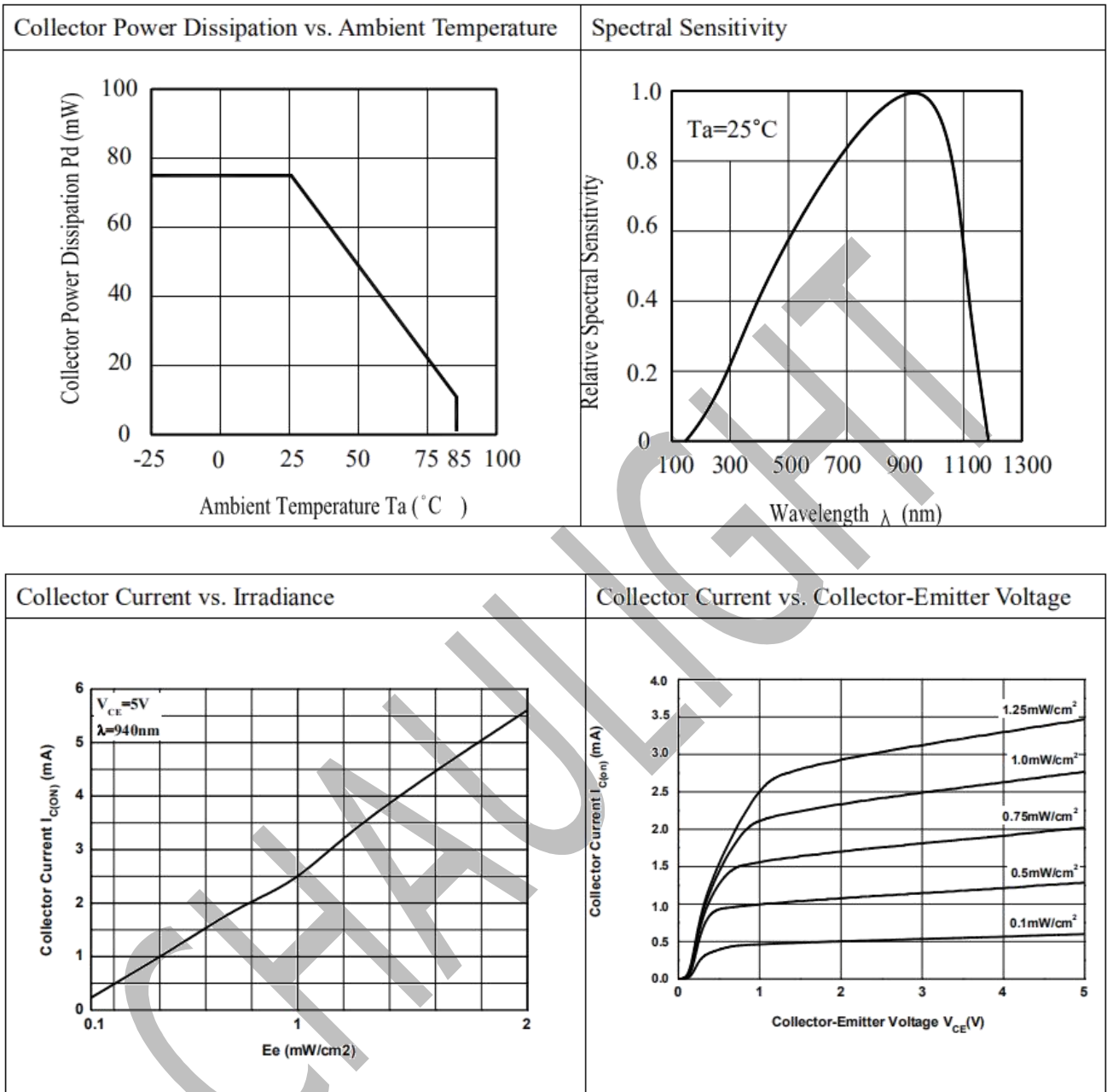

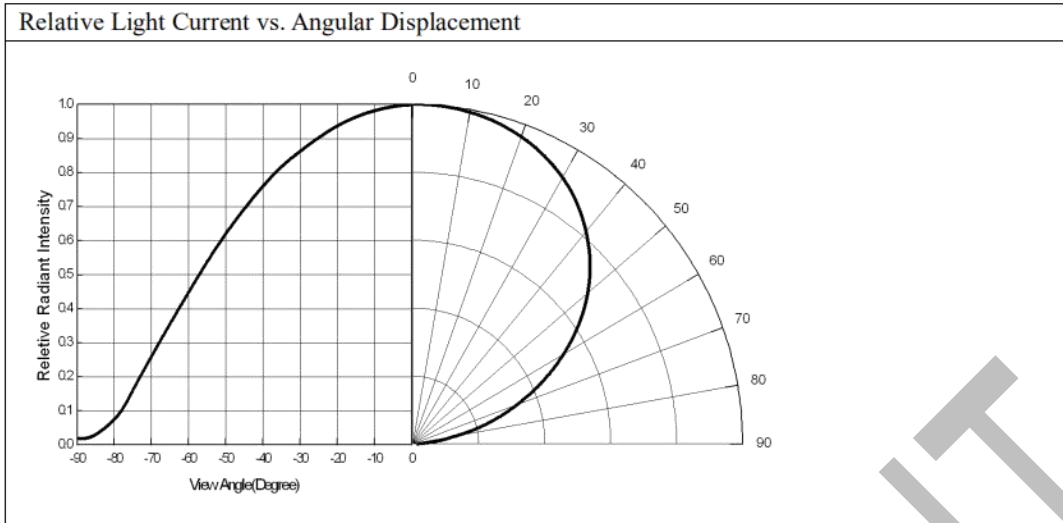

Precautions For Use

1. Over-current-proof

Customer must apply resistors for protection , otherwise slight voltage shift will cause big current change (Burn out will happen).

2. Storage

2.1 Do not open moisture proof bag before the products are ready to use.

2.2 Before opening the package, the Phototransistor should be kept at 30°C or less and 90%RH or less.

2.3 The Phototransistor should be used within a year.

2.4 After opening the package, the Phototransistor should be kept at 30°C or less and 60%RH or less.

2.5 The Phototransistor should be used within 72 hours (3 days) after opening the package

2.6 If the moisture absorbent material (silica gel) has faded away or the Phototransistor have exceeded the storage time, baking treatment should be performed using the following conditions. Baking treatment : 60±5°C for Min. Min. 24 hours.

3. Soldering Condition

3.1 Pb-free solder temperature profile

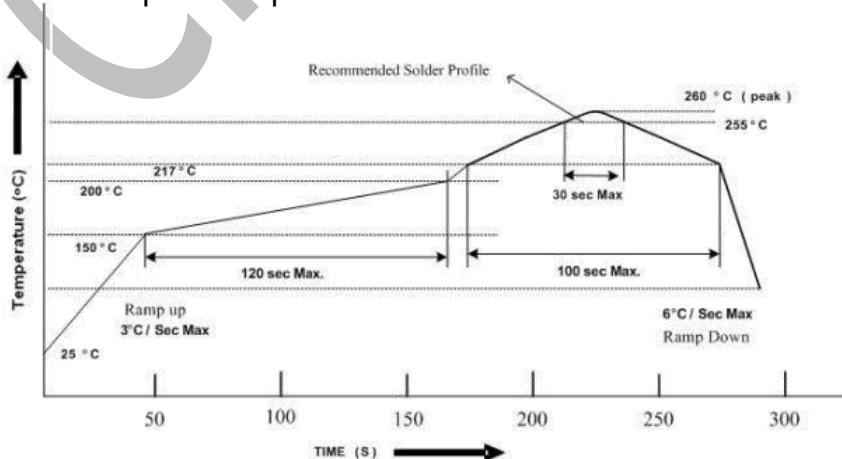



CHAU LIGHT Technical Data Sheet

3.2 Reflow soldering should not be done more than two times.

3.3 When soldering, do not put stress on the Phototransistor during heating.

3.4 After soldering, do not warp the circuit board.

4. Soldering Iron

Each terminal is to go to the tip of soldering iron temperature less than 350°C for 3 seconds within once in less than the soldering iron capacity 25W. Leave two seconds and more intervals, and do soldering of each terminal. Be careful because the damage of the product is often started at the time of the hand solder.

5. Repairing

Repair should not be done after the Phototransistor have been soldered. When repairing is unavoidable, a double-head soldering iron should be used (as below figure). It should be confirmed beforehand whether the characteristics of the Phototransistor will or will not be damaged by repairing.

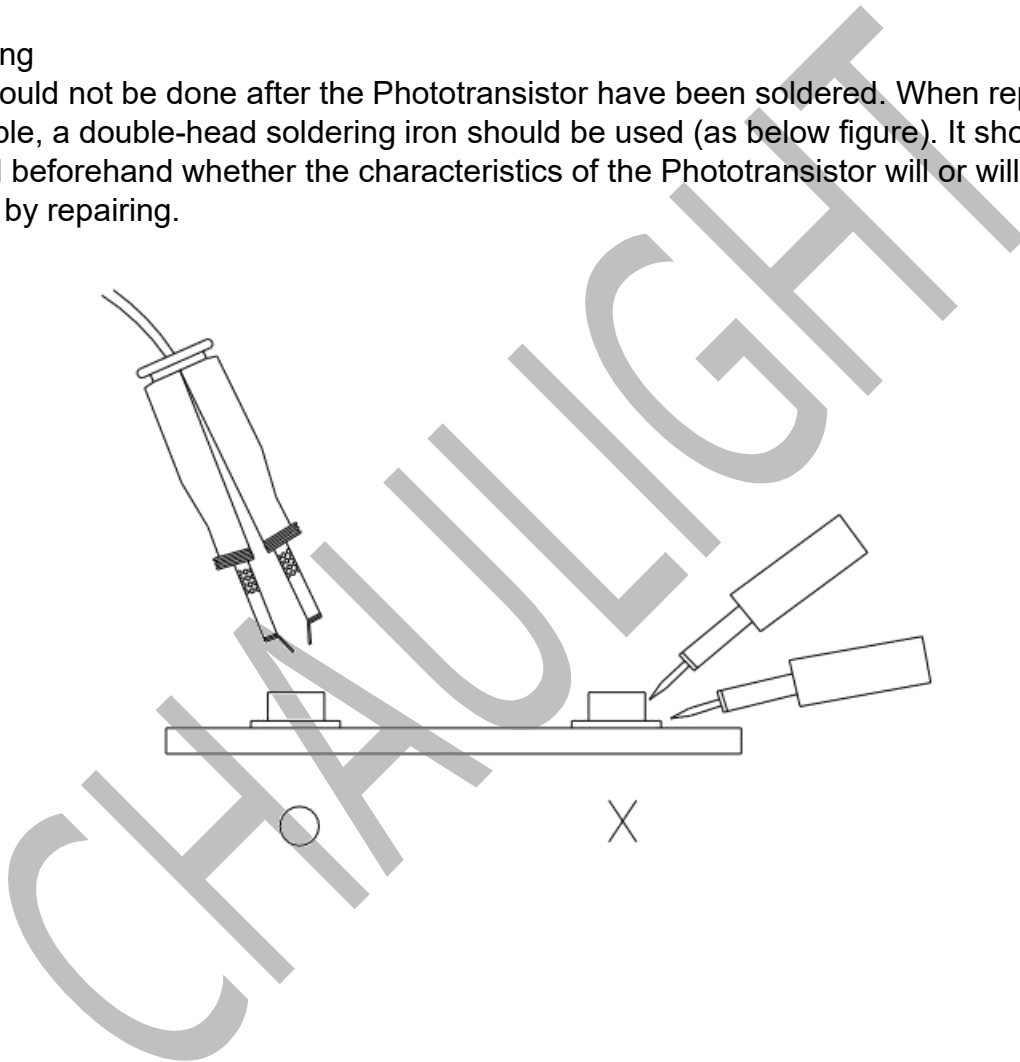



Package Dimensions

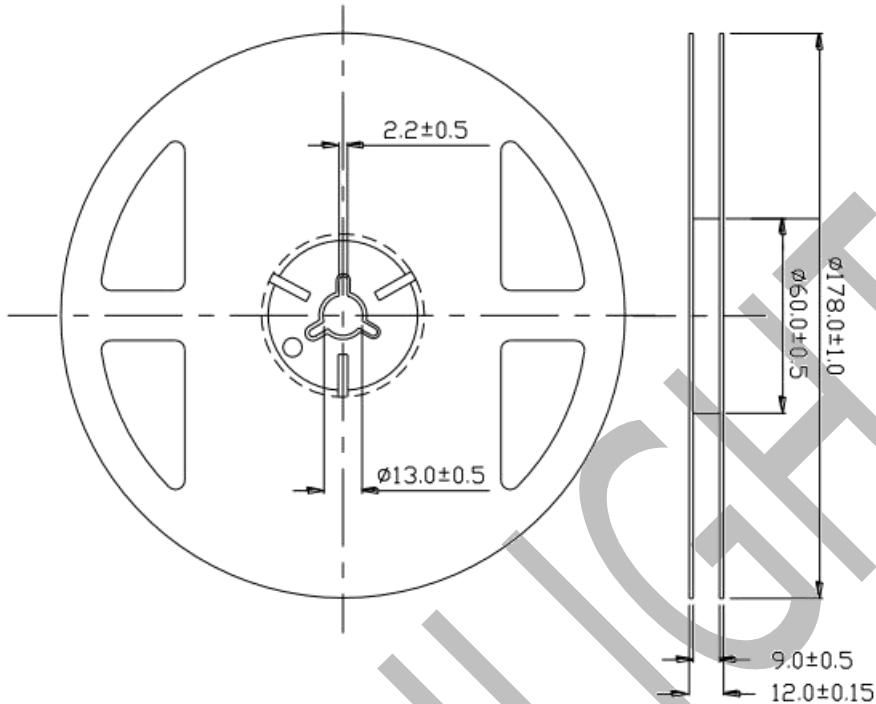

Note: The tolerances unless mentioned is ± 0.1 mm ,Unit = mm

Carrier Tape Dimensions:(Quantity: 2000pcs/reel)

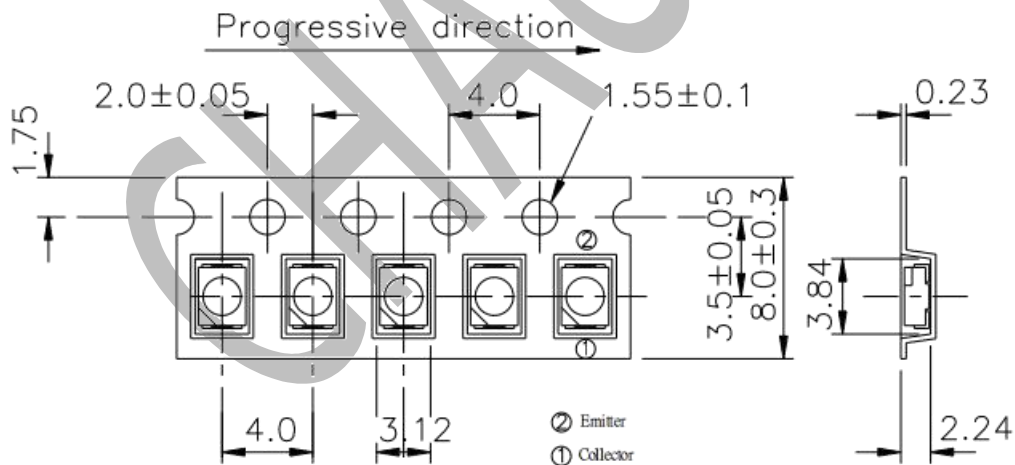

TOLERANCES UNLESS DIMENSION ± 0.1
ANGLE ± 0.5
UNIT:mm

Note: The tolerances unless mentioned is ± 0.1 mm ,Unit = mm



Packing Procedure

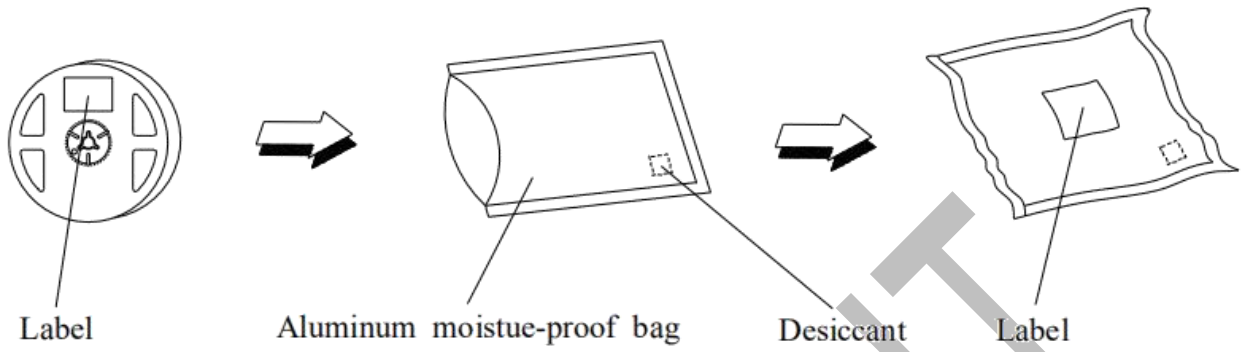

CHAU LIGHT