

Plug-in Signal Conditioners K-UNIT

SIGNAL TRANSMITTER

(isolated)

Functions & Features

- Converting a DC input into a standard process signal
- Isolation up to 2000 V AC
- Fast response type available
- High-density mounting

Typical Applications

- Isolation between control room and field instrumentation

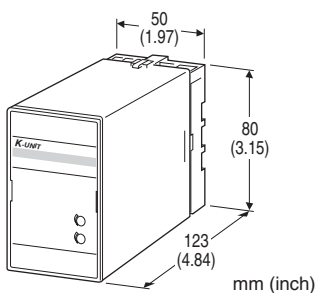

MODEL: KVS-[1][2]-[3][4]

ORDERING INFORMATION

- Code number: KVS-[1][2]-[3][4]
- Specify a code from below for each of [1] through [4].
(e.g. KVS-6A-B/K/Q)
- Special input and output ranges (For codes Z & 0)
 - Specify the specification for option code /Q
(e.g. /C01/V01/S01)

[1] INPUT

Current

- A: 4 - 20 mA DC (Input resistance 250 Ω)
- A1: 4 - 20 mA DC (Input resistance 50 Ω)
- B: 2 - 10 mA DC (Input resistance 500 Ω)
- C: 1 - 5 mA DC (Input resistance 1000 Ω)
- D: 0 - 20 mA DC (Input resistance 50 Ω)
- E: 0 - 16 mA DC (Input resistance 62.5 Ω)
- F: 0 - 10 mA DC (Input resistance 100 Ω)
- G: 0 - 1 mA DC (Input resistance 1000 Ω)
- H: 10 - 50 mA DC (Input resistance 100 Ω)
- J: 0 - 10 μA DC (Input resistance 1000 Ω)
- K: 0 - 100 μA DC (Input resistance 1000 Ω)
- GW: -1 - +1 mA DC (Input resistance 1000 Ω)
- FW: -10 - +10 mA DC (Input resistance 100 Ω)
- Z: Specify current (See INPUT SPECIFICATIONS)

Voltage

- 1: 0 - 10 mV DC (Input resistance 10 kΩ min.)
- 15: 0 - 50 mV DC (Input resistance 10 kΩ min.)
- 16: 0 - 60 mV DC (Input resistance 10 kΩ min.)
- 2: 0 - 100 mV DC (Input resistance 100 kΩ min.)
- 3: 0 - 1 V DC (Input resistance 1 MΩ min.)
- 4: 0 - 10 V DC (Input resistance 1 MΩ min.)
- 5: 0 - 5 V DC (Input resistance 1 MΩ min.)
- 6: 1 - 5 V DC (Input resistance 1 MΩ min.)
- 4W: -10 - +10 V DC (Input resistance 1 MΩ min.)
- 5W: -5 - +5 V DC (Input resistance 1 MΩ min.)
- 0: Specify voltage (See INPUT SPECIFICATIONS)

[2] OUTPUT

Current

- A: 4 - 20 mA DC (Load resistance 750 Ω max.)
- B: 2 - 10 mA DC (Load resistance 1500 Ω max.)
- C: 1 - 5 mA DC (Load resistance 3000 Ω max.)
- D: 0 - 20 mA DC (Load resistance 750 Ω max.)
- E: 0 - 16 mA DC (Load resistance 900 Ω max.)
- F: 0 - 10 mA DC (Load resistance 1500 Ω max.)
- G: 0 - 1 mA DC (Load resistance 15 kΩ max.)
- Z: Specify current (See OUTPUT SPECIFICATIONS)

Voltage

- 1: 0 - 10 mV DC (Load resistance 10 kΩ min.)
- 2: 0 - 100 mV DC (Load resistance 100 kΩ min.)
- 3: 0 - 1 V DC (Load resistance 100 Ω min.)
- 4: 0 - 10 V DC (Load resistance 1000 Ω min.)
- 5: 0 - 5 V DC (Load resistance 500 Ω min.)
- 6: 1 - 5 V DC (Load resistance 500 Ω min.)
- 4W: -10 - +10 V DC (Load resistance 2000 Ω min.)
- 5W: -5 - +5 V DC (Load resistance 1000 Ω min.)
- 0: Specify voltage (See OUTPUT SPECIFICATIONS)

[3] POWER INPUT

AC Power

- B: 100 V AC
- C: 110 V AC
- D: 115 V AC
- F: 120 V AC
- G: 200 V AC
- H: 220 V AC
- J: 240 V AC

DC Power

- S: 12 V DC
- R: 24 V DC

[4] OPTIONS (multiple selections)

Response Time (0 - 90 %)

- blank: Standard (≤ 0.5 sec.)
- /K: Fast Response (Approx. 25 msec.)

Other Options

blank: none

/Q: Option other than the above (specify the specification)

SPECIFICATIONS OF OPTION: Q (multiple selections)

COATING (For the detail, refer to M-System's web site.)

/C01: Silicone coating

/C02: Polyurethane coating

/C03: Rubber coating

ADJUSTMENT

/V01: Multi-turn fine adjustment

TERMINAL SCREW MATERIAL

/S01: Stainless steel

GENERAL SPECIFICATIONS

Construction: Plug-in

Connection: M3.5 screw terminals

Screw terminal: Chromated steel (standard) or stainless steel

Housing material: Flame-resistant resin (black)

Isolation: Input to output to power

Overrange output: Approx. -10 to +120 % at 1 - 5 V

Zero adjustment: -5 to +5 % (front)

Span adjustment: 95 to 105 % (front)

INPUT SPECIFICATIONS

■ DC Current:

Shunt resistor attached to the input terminals (0.5 W)

Specify input resistance value for code Z.

■ DC Voltage: -300 - +300 V DC

Minimum span: 3 mV

Offset: Max. 1.5 times span

Input resistance

Span 3 - 10 mV : $\geq 10 \text{ k}\Omega$

Span 10 - 100 mV : $\geq 10 \text{ k}\Omega$

Span 0.1 - 1 V : $\geq 100 \text{ k}\Omega$

Span $\geq 1 \text{ V}$: $\geq 1 \text{ M}\Omega$

OUTPUT SPECIFICATIONS

■ DC Current: 0 - 20 mA DC

Minimum span: 1 mA

Offset: Max. 1.5 times span

Load resistance: Output drive 15 V max.

■ DC Voltage: -10 - +12 V DC

Minimum span: 5 mV

Offset: Max. 1.5 times span

Load resistance: Output drive 10 mA max.; 5 mA for negative voltage output; at $\geq 0.5 \text{ V}$

INSTALLATION

Power input

• **AC:** Operational voltage range: rating $\pm 10 \%$, 50/60 $\pm 2 \text{ Hz}$, approx. 2 VA

• **DC:** Operational voltage range: rating $\pm 10 \%$, ripple 10 %p-p max., approx. 2 W (80 mA at 24 V)

Operating temperature: -5 to +55°C (23 to 131°F)

Operating humidity: 30 to 90 %RH (non-condensing)

Mounting: Surface or DIN rail

Weight: 400 g (0.88 lb)

PERFORMANCE in percentage of span

Accuracy: $\pm 0.1 \%$

Temp. coefficient: $\pm 0.02 \text{ \%}/^\circ\text{C}$ ($\pm 0.01 \text{ \%}/^\circ\text{F}$)

Line voltage effect: $\pm 0.1 \%$ over voltage range

Insulation resistance: $\geq 100 \text{ M}\Omega$ with 500 V DC

Dielectric strength: 2000 V AC @1 minute (input to output to power to ground)

EXTERNAL DIMENSIONS unit: mm (inch)

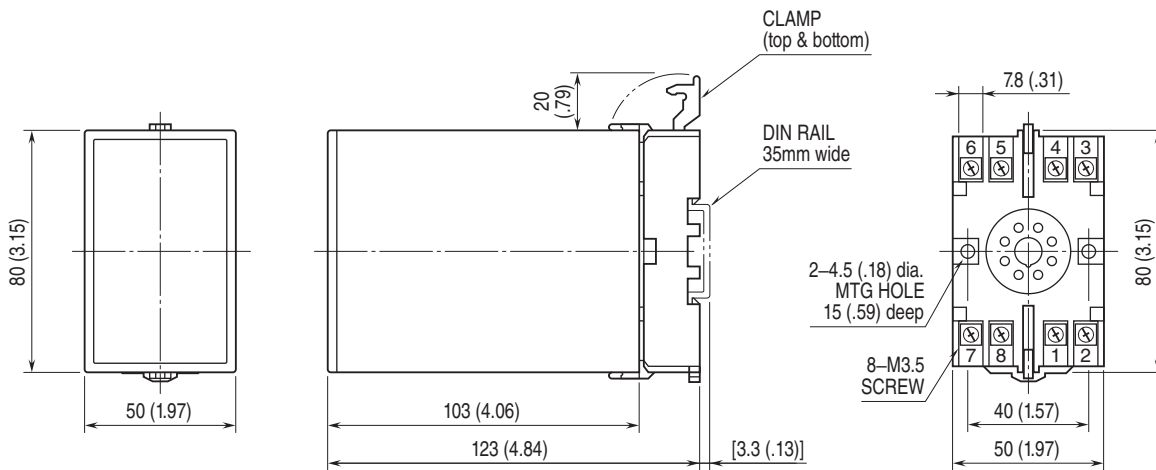

• When mounting, no extra space is needed between units.

TERMINAL ASSIGNMENTS unit: mm (inch)

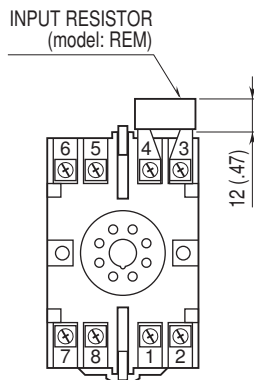

Input shunt resistor attached for current input.

SCHEMATIC CIRCUITRY & CONNECTION DIAGRAM

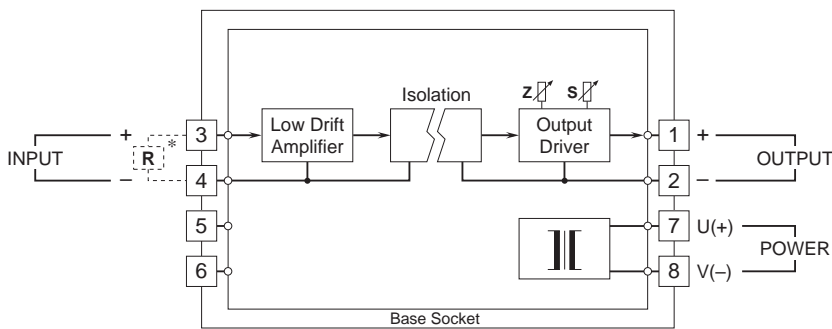

*Input shunt resistor attached for current input.



Specifications are subject to change without notice.