

Dual Output Super-mini Signal Conditioners Pico-M Series

THERMOCOUPLE CONVERTER

(PC programmable, CE)

Functions & Features

- Converts a wide variety of thermocouple input into two isolated, linearized process signals
- PC programmable
- Cold junction compensation
- Linearization
- Burnout protection
- User's temperature table can be used
- Space-saving, easy-to-maintain, multi-channel installation base

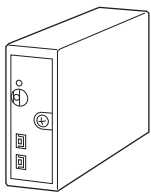

MODEL: M8XT3-[1][2]-R[3]

ORDERING INFORMATION

- Code number: M8XT3-[1][2]-R[3]

Specify a code from below for each of [1] through [3].

- (e.g. M8XT3-2V2V2-R/Q)
- Input range (e.g. 0 - 800°C)
- Output 1 / Output 2 (e.g. 1 - 5 V / 1 - 5 V DC)

K thermocouple setting will be used if the input code is not specified. If no I/O specifications are specified, model M8XT3-2V2V2-R/Q will be shipped.

For the input suffix code 0, use Ordering Information Sheet (No. ESU-5470).

- Specify the specification for option code /Q (e.g. /C01)

[1] INPUT THERMOCOUPLE

- 1: (PR) (Usable Range 0 to 1760°C, 32 to 3200°F)
- 2: K (CA) (Usable range -270 to +1370°C, -454 to +2498°F)
- 3: E (CRC) (Usable range -270 to +1000°C, -454 to +1832°F)
- 4: J (IC) (Usable range -210 to +1200°C, -346 to +2192°F)
- 5: T (CC) (Usable range -270 to +400°C, -454 to +752°F)
- 6: B (RH) (Usable range 0 to 1820°C, 32 to 3308°F)
- 7: R (Usable range -50 to +1760°C, -58 to +3200°F)
- 8: S (Usable range -50 to +1760°C, -58 to +3200°F)
- 9: C (WRe 5-26) (Usable range 0 to 2315°C, 32 to 4199°F)
- N: N (Usable range -270 to +1300°C, -454 to +2372°F)
- U: U (Usable Range -200 to +400°C, -328 to +752°F)

- L: L (Usable Range -200 to +900°C, -328 to +1652°F)
- P: P (Platinel II) (Usable Range 0 to 1395°C, 32 to 2543°F)
- 0: Specify (Configurator software is used to change the input type and range.)

[2] OUTPUT 1 / OUTPUT 2

V2Z1: Range -10 - +10 V DC / Range 0 - 20 mA DC

V2V2: Range -10 - +10 V DC / Range -10 - +10 V DC

(Configurator software is used to change output over the described range of the selected suffix code.

For changing between suffix codes, set the Output Range Selector on the side of unit before software adjustment.)

POWER INPUT

DC Power

R: 24 V DC

(Operational voltage range 24 V ±10 %, ripple 10 %p-p max.)

[3] OPTIONS

blank: none

/Q: With options (specify the specification)

SPECIFICATIONS OF OPTION: Q

COATING (For the detail, refer to M-System's web site.)

/C01: Silicone coating

/C02: Polyurethane coating

/C03: Rubber coating

RELATED PRODUCTS

- Installation Base or Single Mount Base Socket (model: M8BSx)

This unit must be mounted on dedicated base or socket except Model M8BS-1-1 socket.

- PC configurator software (model: JXCON)

Downloadable at M-System's web site.

A dedicated cable is required to connect the module to the PC. Please refer to the internet software download site or the users manual for the PC configurator for applicable cable types.

GENERAL SPECIFICATIONS

Construction: Plug-in

Mounting screw: M3 screw (torque 0.3 N·m)

Housing material: Flame-resistant resin (black)

Power supply: Via the Installation Base terminals (model: M8BSx)

Isolation: Input to output 1 to output 2 to power

Overrange output: Approx. -15 to +115 %

Manual zero adjustments: -5 to +5 %

(factory setting: 0 %)

Manual span adjustments: 95 to 105 %

(factory setting: 100 %)

Programming: Downloaded from PC; T/C type, temp. range, output range, zero and span, simulating output, user's temperature table, linearization, etc.

Burnout protection: Upscale standard; downscale or no burnout optional by programming

(Set to "no burnout" when the unit is connected with another instrument in parallel.)

Cold junction compensation: CJC sensor attached to the input terminals

Status indicator LED: Blinking patterns indicate different operating status of the transmitter.

Configurator connection: 2.5 dia. miniature jack; RS-232-C level

INPUT SPECIFICATIONS

Input resistance: 1 M Ω min.

Burnout sensing: 45 nA \pm 10 %

Minimum span: 20°C or 36°F

Offset: Lower range can be any specific value within the input range provided that the minimum span is maintained.

For temperatures ranges near lower limit of the usable range, the transmitter may not satisfy the described accuracy. Consult M-System.

If not specified, the input range is shown below.

1 PR: 0-1600°C

2 K: 0-1000°C

3 E: 0-500°C

4 J: 0-500°C

5 T: 0-300°C

6 B: 0-1800°C

7 R: 0-1600°C

8 S: 0-1600°C

9 C: 0-2000°C

N N: 0-1000°C

U U: 0-300°C

L L: 0-500°C

P P: 0-1200°C

OUTPUT SPECIFICATIONS

■ **DC Current:** 0 - 20 mA DC

Operational range: 0 - 24 mA DC

Minimum span: 1 mA

Offset: Lower range can be any specific value within the output range provided that the minimum span is maintained.

Load resistance: Output drive 6 V max.

(e.g. 4 - 20 mA: 300 Ω [6 V \div 20 mA])

■ **DC Voltage:** -10 - +10 V DC

Operational range: -11.5 - +11.5 V DC

Minimum span: 1 V

Offset: Lower range can be any specific value within the output range provided that the minimum span is maintained.

Load resistance: Output drive 1 mA max.

(e.g. 1 - 5 V: 5000 Ω [5 V \div 1 mA])

If not specified, the output range is shown below.

V2Z1: 1 - 5 V / 4 - 20 mA DC

V2V2: 1 - 5 V / 1 - 5 V DC

INSTALLATION

Current consumption: Approx. 50 mA (70 mA for current output)

Operating temperature: 0 to 55°C (32 to 131°F)

Operating humidity: 30 to 95 %RH (non-condensing)

Mounting: Installation Base (model: M8BSx)

Weight: 70 g (2.5 oz)

PERFORMANCE

Accuracy: Input accuracy + output accuracy
Inversely proportional to the span.

See HOW TO CALCULATE THE ACCURACY.

• **Input accuracy:** (% of input range)

(PR): \pm 0.04 %

K (CA): \pm 0.01 %

E (CRC): \pm 0.02 %

J (IC): \pm 0.02 %

T (CC): \pm 0.03 %

B (RH): \pm 0.06 %

R: \pm 0.04 %

S: \pm 0.04 %

C (WRe 5-26): \pm 0.02 %

N: \pm 0.02 %

U: \pm 0.02 %

L: \pm 0.02 %

P (Platinel II): \pm 0.02 %

• **Output accuracy:** (% of output range)

-10 - +10 V: \pm 0.02 %

0 - 20 mA: \pm 0.04 %

Cold junction compensation error: \pm 0.5°C or \pm 0.9°F

(at 20°C \pm 10°C or 68°F \pm 18°F)

Temp. coefficient: \pm 0.015 %/°C (\pm 0.008 %/°F) of I/O range at 0 to 55°C [32 to 131°F]

Response time: \leq 0.9 sec. (0 - 90 %)

Burnout response: \leq 10 sec.

Line voltage effect: \pm 0.1 % over voltage range

Insulation resistance: \geq 100 M Ω with 500 V DC

Dielectric strength:

1500 V AC @1 minute (input to output 1 or output 2 or power to ground)
 500 V AC @1 minute (output 1 to output 2 to power)

EN 50581

HOW TO CALCULATE THE ACCURACY

■ Overall Accuracy

[Example] K, 0 - 1000°C, 1 - 5 V output

Input Accuracy

$$\begin{aligned}
 &= \text{Max. Range} \div \text{Input Span} \times \text{Input Accuracy} \\
 &= 1640 \div 1000 \times 0.01 \\
 &= 0.02
 \end{aligned}$$

Output Accuracy

$$\begin{aligned}
 &= \text{Max. Range} \div \text{Output Span} \times \text{Output Accuracy} \\
 &= 20 \div 4 \times 0.02 \\
 &= 0.1
 \end{aligned}$$

Overall Accuracy

$$\begin{aligned}
 &= 0.02 + 0.1 \\
 &= \pm 0.12 \%
 \end{aligned}$$

■ Accuracy with a User's Temperature Table

Custom input accuracy + output accuracy
 (Inversely proportional to the span)

Input Accuracy: $100 \% \times 5 \mu\text{V} \div \text{Input Span}$

The accuracy applies only at the user's calibration points.

Data between each point is approximated with a linear line, thus is not applicable.

Output Accuracy: $\leq \pm 0.04 \%$

[Example] 10000 μV span input, 1 - 5 V output

Custom input Accuracy = $5 \div 10000 \times 100 = 0.05$

Output Accuracy = $20 \div 4 \times 0.04 = 0.2$

Overall Accuracy = $0.05 + 0.2 = \pm 0.25 \%$

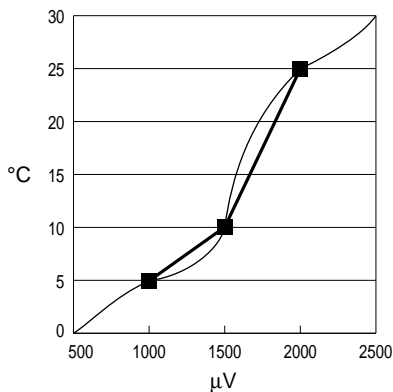

Approximated Line Actual Line
 Data Point

STANDARDS & APPROVALS

EU conformity:

EMC Directive

EMI EN 61000-6-4

EMS EN 61000-6-2

RoHS Directive

EXTERNAL VIEWS

■ SIDE VIEW

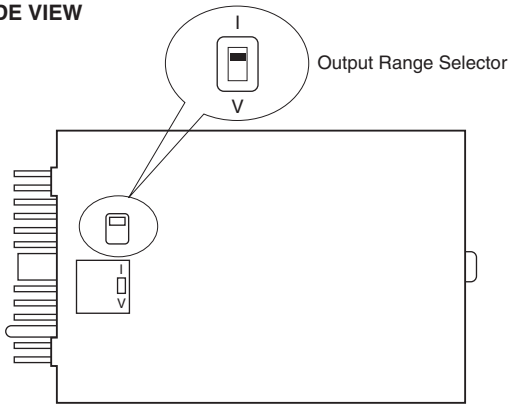

■ FRONT VIEW

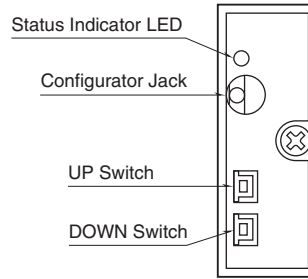

■ BOTTOM VIEW

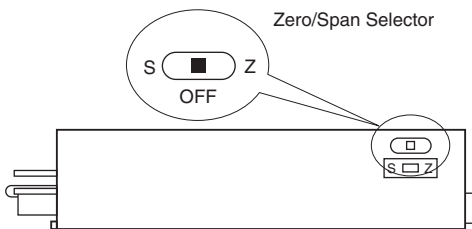

Output Range Selector

(SW POSITION: RANGE)

I: V2Z1 (-10 - +10 V / 0 - 20 mA DC)

V: V2V2 (-10 - +10 V / -10 - +10 V DC)

Zero/Span Selector

(SW POSITION: MODE)

S: SPAN

Center: OFF

Z: ZERO

Zero/Span is calibrated by using UP/DOWN switches when the calibration mode is set. Refer to the instruction manual for detailed procedures.

EXTERNAL DIMENSIONS unit: mm (inch)

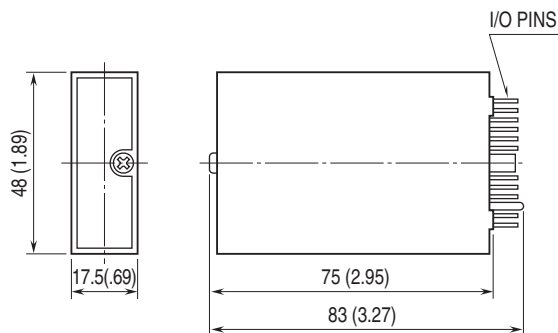

SCHEMATIC CIRCUITRY & CONNECTION DIAGRAM

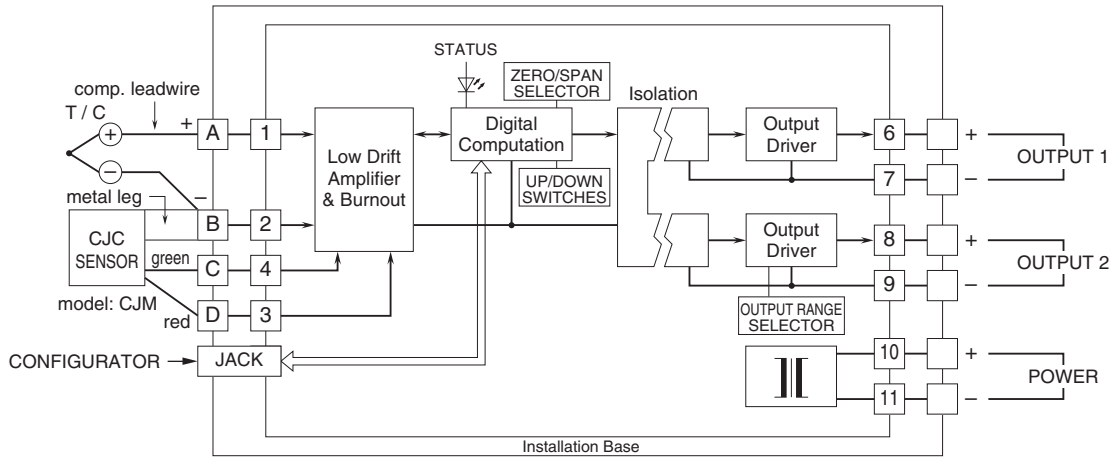

Specifications are subject to change without notice.