

FEATURES

- State-of-the-Art Broadband Detector Technology
- Schottky Diode Front End with on-Chip Linearization
- Boardband 50 ohm Input Impedance
- Accurate Response from 0.5 GHz to 40 GHz
- Input Range of -30 dBm to +15 dBm re 50Ω
- Unity Gain Scaled Linear in V/V Output
- Fast Incremental Envelope Response: >20MHz
- Low Power Consumption: 3.0 mA at 5V
- 2 mm × 2 mm, 6-lead LFCSP package

APPLICATIONS

- High-precision Microwave Instrumentation
- Point-to-Point Power-Level Control
- Collision-Avoidance Systems

GENERAL DESCRIPTION

The ADL6010 is a versatile, broadband RF envelope detector. The envelope output voltage is presented as a voltage that is proportional to the envelope of the input signal. Absolute power measurement can be made with a simple low pass filter design at the output of the ADL6010.

The ADL6010 provides state-of-the-art accuracy and stability over time and temperature, in a simple 6-pin format. It features a novel detector cell using Schottky diodes and a proprietary linearizing system. The device has a specified input power, relative to a 50-Ω environment ranges, of -30 dBm to +15 dBm. Traditional diode-based detectors exhibit significant even-order nonlinearity, due to source loading, generating distortion

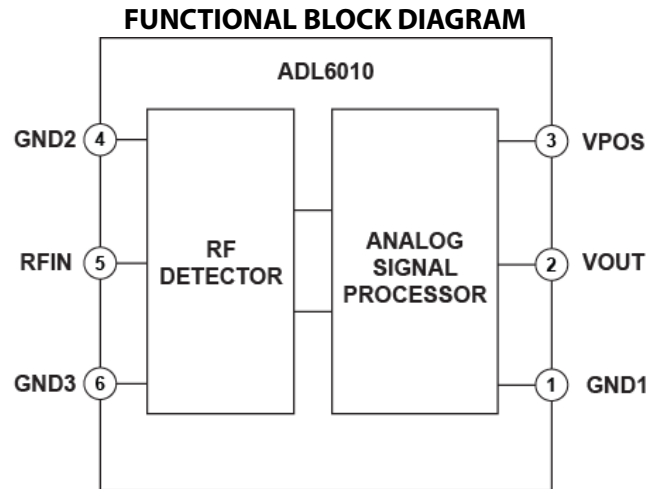

Figure 1. Functional block diagram

components which are reflected into the signal source. The ADL6010 detector does not exhibit this behavior – an important benefit in applications where a low-ratio coupler is used to extract a sample of the primary signal.

The supply voltage may range from 3.3 V up to 5.5 V, with no degradation in the response accuracy. The zero-signal current consumption is less than 3 mA.

The ADL6010 operates from -55°C to +125°C and is available in a 6-lead, 2 mm × 2 mm LFCSP package.

Rev. PrB

Information furnished by Analog Devices is believed to be accurate and reliable. However, no responsibility is assumed by Analog Devices for its use, nor for any infringements of patents or other rights of third parties that may result from its use. Specifications subject to change without notice. No license is granted by implication or otherwise under any patent or patent rights of Analog Devices. Trademarks and registered trademarks are the property of their respective owners.

TABLE OF CONTENTS

Features	1	Thermal Resistance	5
Applications.....	1	ESD Caution.....	5
Functional Block Diagram	1	Pin Configuration and Function Descriptions.....	6
General Description	1	Typical Performance Characteristics	7
Revision History	Error! Bookmark not defined.	Outline Dimensions	10
Specifications.....	3	Ordering Guide.....	10
Absolute Maximum Ratings.....	5		

SPECIFICATIONS

T_A = 25°C, VPOS = 5V, unless otherwise stated.

Table 1.

Parameter	Test Conditions	Min	Typ	Max	Unit
FREQUENCY RANGE	Input RFIN	500		40	MHz GHz
RF INPUT Input Impedance			50		Ω
f = 1 GHz	Input RFIN to output VOUT				
Dynamic Range					
±0.5 dB Error	CW input, T _A = +25°C		40		dB
±1 dB Error	CW input, T _A = +25°C		45		dB
Maximum Input Level, ±1 dB			15		dBm
Minimum Input Level, ±1 dB			-30		dBm
Conversion Gain	VOUT = (Gain × V _{IN}) + Intercept		1		V/V rms
Output Intercept			0		V
Output Voltage, High Power In	P _{in} = +15 dBm		4		V
Output Voltage, Low Power In	P _{in} = -30 dBm		0.03		V
f = 10 GHz	Input RFIN to output VOUT				
Dynamic Range					
±0.5 dB Error	CW input, T _A = +25°C		40		dB
±1 dB Error	CW input, T _A = +25°C		45		dB
Maximum Input Level, ±1 dB			18		dBm
Minimum Input Level, ±1 dB			-30		dBm
Conversion Gain	VOUT = (Gain × V _{IN}) + Intercept		1		V/V rms
Output Intercept			0		V
Output Voltage, High Power In	P _{in} = +15 dBm		4		V
Output Voltage, Low Power In	P _{in} = -30 dBm		0.03		V
f = 20 GHz	Input RFIN to output VOUT				
Dynamic Range					
±0.5 dB Error	CW input, T _A = +25°C		40		dB
±1 dB Error	CW input, T _A = +25°C		45		dB
Maximum Input Level, ±1 dB			15		dBm
Minimum Input Level, ±1 dB			-30		dBm
Conversion Gain	VOUT = (Gain × V _{IN}) + Intercept		1		V/V rms
Output Intercept			0		V
Output Voltage, High Power In	P _{in} = +15 dBm		4		V
Output Voltage, Low Power In	P _{in} = -30 dBm		0.02		V
f = 30 GHz	Input RFIN to output VOUT				
Dynamic Range					
±0.5 dB Error	CW input, T _A = +25°C		40		dB
±1 dB Error	CW input, T _A = +25°C		45		dB
Maximum Input Level, ±1 dB			15		dBm
Minimum Input Level, ±1 dB			-30		dBm
Conversion Gain	VOUT = (Gain × V _{IN}) + Intercept		1		V/V rms
Output Intercept			0		V
Output Voltage, High Power In	P _{in} = +15 dBm		4		V
Output Voltage, Low Power In	P _{in} = -30 dBm		0.03		V
f = 40 GHz	Input RFIN to output VOUT				

Dynamic Range					
±0.5 dB Error	CW input, $T_A = +25^\circ\text{C}$	30			dB
±1 dB Error	CW input, $T_A = +25^\circ\text{C}$	35			dB
Maximum Input Level, ±1 dB		15			dBm
Minimum Input Level, ±1 dB		-25			dBm
Conversion Gain	$V_{OUT} = (\text{Gain} \times V_{IN}) + \text{Intercept}$	1			V/V rms
Output Intercept		0			V
Output Voltage, High Power In	$P_{in} = +15 \text{ dBm}$	4			V
Output Voltage, Low Power In	$P_{in} = -30 \text{ dBm}$	0.05			V
VOUT OUTPUT	Pin VOUT				
Maximum Output Voltage		4			V
Output Offset	No signal at RFIN	TBD			mV
Available Output Current		TBD			mA
Envelope Modulation Bandwidth		50			MHz
POWER SUPPLIES					
Operating Range	$-55^\circ\text{C} \leq T_A \leq 125^\circ\text{C}$	2.7	5.0	5.5	V
Quiescent Current			3.0		mA

ABSOLUTE MAXIMUM RATINGS

Table Summary

Table 2.

Parameter	Rating
Supply Voltage, VPOS	TBD
RFIN	TBD
Maximum Junction Temperature	TBD
Operating Temperature Range	TBD
Storage Temperature Range	TBD

Stresses above those listed under Absolute Maximum Ratings may cause permanent damage to the device. This is a stress rating only; functional operation of the device at these or any other conditions above those indicated in the operational section of this specification is not implied. Exposure to absolute maximum rating conditions for extended periods may affect device reliability.

THERMAL RESISTANCE

θ_{JA} is specified for the worst-case conditions, that is, a device soldered in a circuit board for surface-mount packages.

Table 3. Thermal Resistance

Package Type	θ_{JA}	θ_{JC}	Unit
TBD	TBD	TBD	°C/W

ESD CAUTION



ESD (electrostatic discharge) sensitive device. Charged devices and circuit boards can discharge without detection. Although this product features patented or proprietary protection circuitry, damage may occur on devices subjected to high energy ESD. Therefore, proper ESD precautions should be taken to avoid performance degradation or loss of functionality.

PIN CONFIGURATION AND FUNCTION DESCRIPTIONS

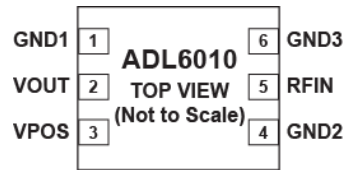

Figure 2. Pin Configuration

Table 4. Pin Function Descriptions

Pin No.	Mnemonic	Description
1, 4, 6, EPAD	GND	Device Ground Pins. Pin 1, 4 and 6 are ground pins and the metal slug on the underside of the chip must be connected to a low impedance ground plane.
2	VOUT	Envelop Peak Output.
3	VPOS	Supply Voltage Pin. The operational range is from 2.5 V to 5.5 V.
5	RFIN	Signal Input Pin. This pin is ac-coupled and has an input impedance of approximately 50 ohms.

TYPICAL PERFORMANCE CHARACTERISTICS

$V_{pos} = 5V$; single-ggended input drive, $T_A = -40^\circ C$ (Blue), $+25^\circ C$ (Green) and $+85^\circ C$ (Red), input signal is a sine wave (CW), unless otherwise indicated.

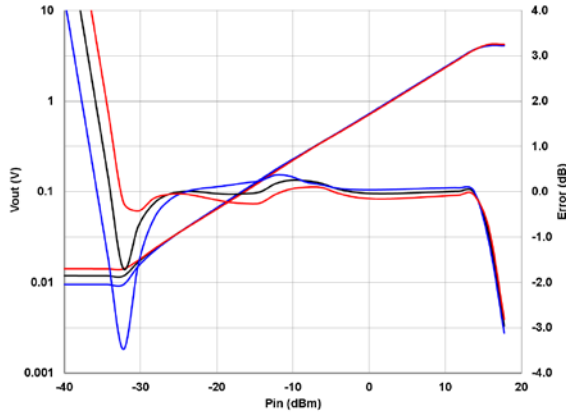

Figure 3 V_{OUT} and Conformance Error vs. P_{in} and Temperature at 1GHz.

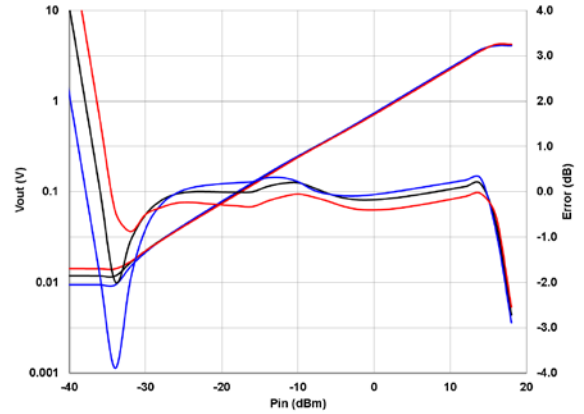

Figure 5 V_{OUT} and Conformance Error vs. P_{in} and Temperature at 15GHz.

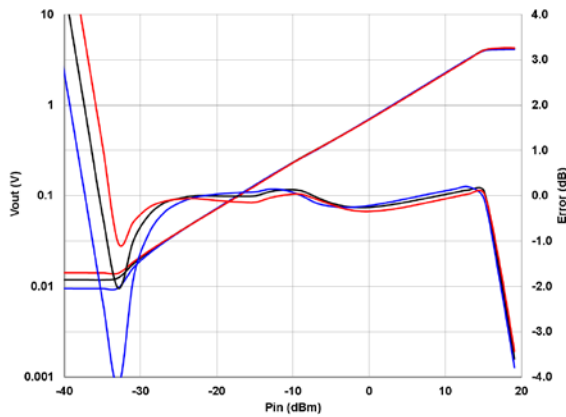

Figure 4 V_{OUT} and Conformance Error vs. P_{in} and Temperature at 5GHz.

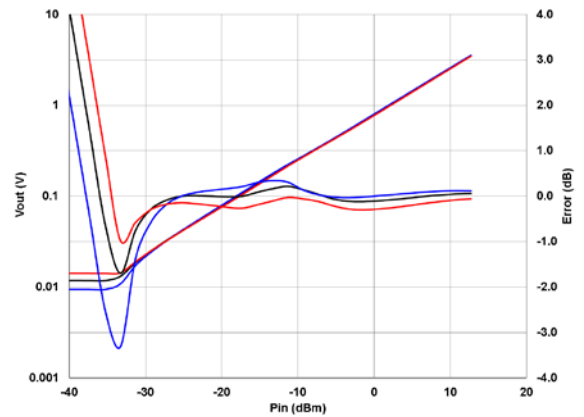

Figure 7 V_{OUT} and Conformance Error vs. P_{in} and Temperature at 20GHz (Data Truncated by Measurement Setup).

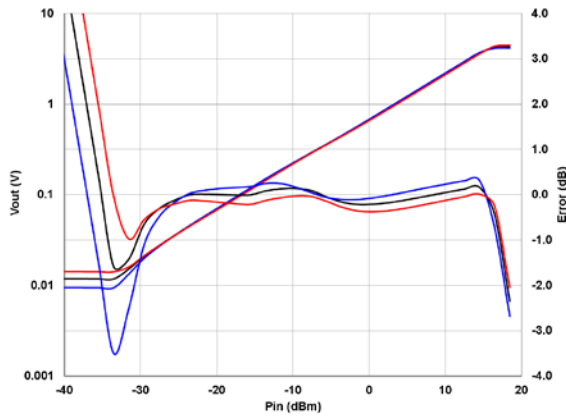

Figure 5 V_{OUT} and Conformance Error vs. P_{in} and Temperature at 10GHz.

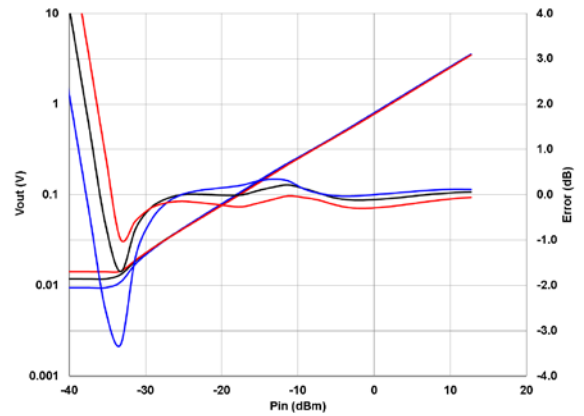

Figure 8 V_{OUT} and Conformance Error vs. P_{in} and Temperature at 25GHz. (Data Truncated by Measurement Setup).

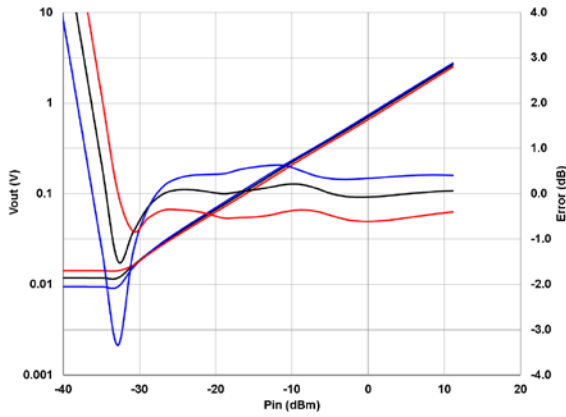

Figure 9 V_{OUT} and Conformance Error vs. P_{in} and Temperature at 30GHz (Data Truncated by Measurement Setup).

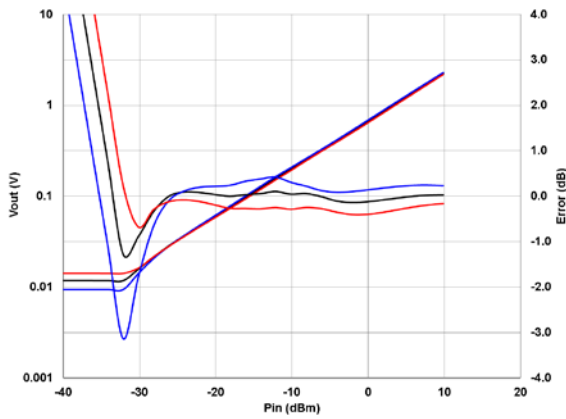

Figure 10 V_{OUT} and Conformance Error vs. P_{in} and Temperature at 35GHz (Data Truncated by Measurement Setup).

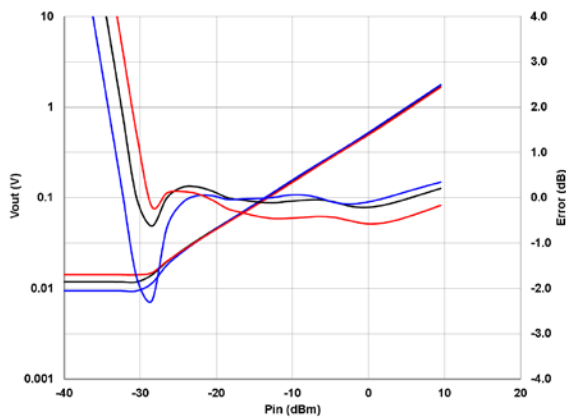

Figure 11 V_{OUT} and Conformance Error vs. P_{in} and Temperature at 40GHz (Data Truncated by Measurement Setup).

EVALUATION BOARD

The ADL6010-EVALZ is a fully populated, 4-layer, Rogers 4003-based evaluation board. For normal operation, it requires a 5V/27mA power supply. The 5V power supply must be connected to the VPOS and GND test loops. The RF input

signal is applied to the 2.92 mm connector (RFIN). The output voltage is available on the SMA connector (VOUT) or on the test loop (V_VOUT). Configuration options for the evaluation board are listed in Table 5.

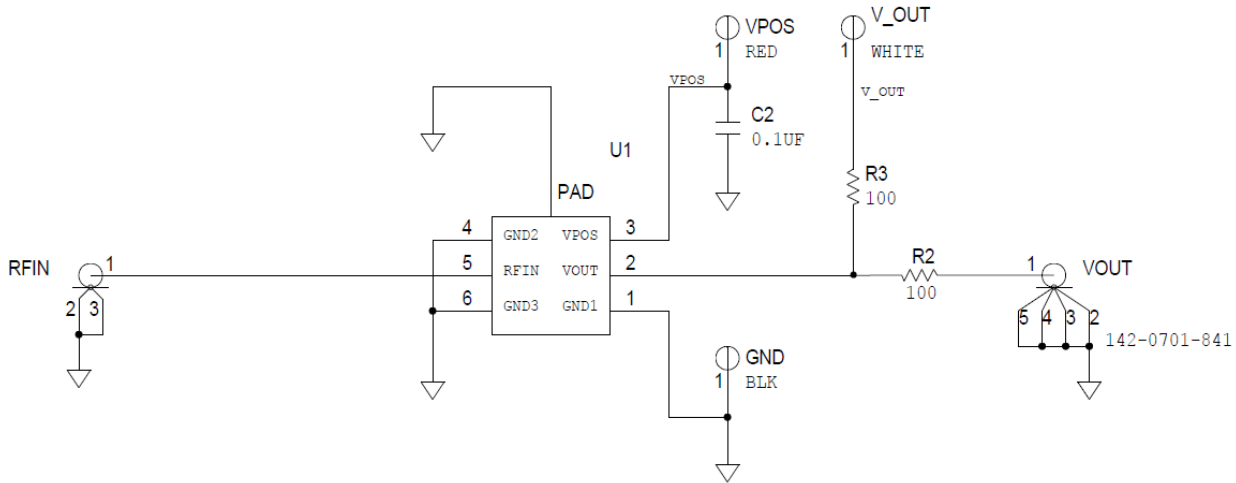

Figure 13 ADL6010 Evaluation Board Schematics

Table 5. Evaluation Board Configuration Options

Component	Function/Notes	Default Value
R2, R3	Output interface. A 100 ohm series resistor should be used in the presence of large capacitive loads. R3 can be replaced with a 0 ohm resistor.	R2 = 100 Ω (size: 0402) R3 = 100 Ω (size: 0402)
C2	Bypass capacitor. It provides supply ac decoupling by forming a return path for the ac signal and reduces the noise at the input end. The nominal value is 0.1µF.	C2 = 0.1µF (size: 0402)
RFIN	RF Input. Southwest microwave 2.92 mm connector is used for input interface.	

OUTLINE DIMENSIONS

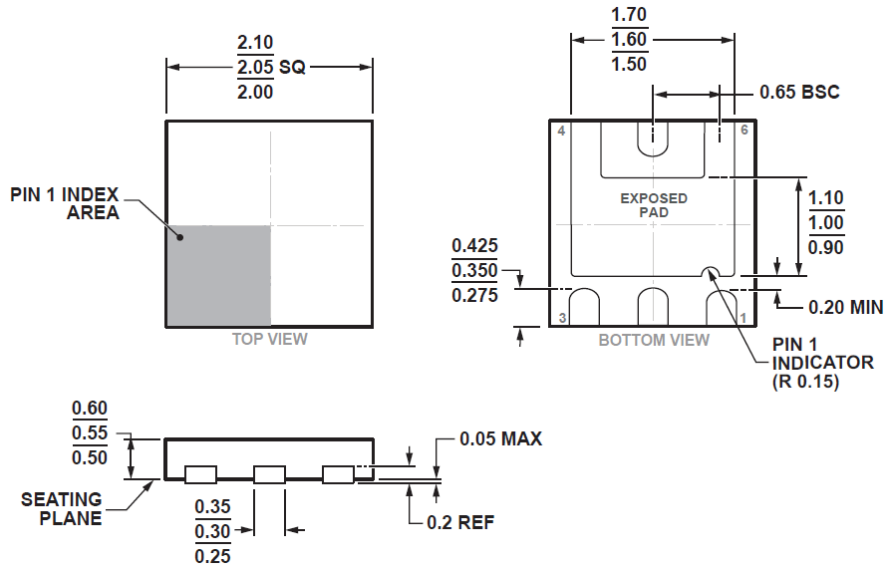

Figure 14. 6-Lead Lead Frame Chip Scale Package [LFCSP_UD]
 2 mm x 2 mm Body, Ultra Thin, Dual Lead (CP-6-7)
 Dimensions shown in millimeters.

ORDERING GUIDE

Model	Temperature Range	Package Description	Package Option	Ordering Quantity
ADL6010ACPZN-R2	-40°C to +85°C	6-Lead Lead Frame Chip Scale Package	CP-6-7	250
ADL6010ACPZN-R7	-40°C to +85°C	6-Lead Lead Frame Chip Scale Package	CP-6-7	1500
ADL6010SCPZN-R2	-55°C to +125°C	6-Lead Lead Frame Chip Scale Package	CP-6-7	250
ADL6010SCPZN-R7	-55°C to +125°C	6-Lead Lead Frame Chip Scale Package	CP-6-7	1500
ADL6010-EVALZ		Evaluation Board		1