



**SMD
BALUN
TRANSFORMERS**

Token Electronics Industry Co., Ltd.

Taiwan: No. 137, Sec. 1, Chung Shin Rd., Wu Ku Hsiang, Taipei Hsien, Taiwan, R.O.C
TEL: 886-2-2981 0109; FAX: 886-2-2988 7487

China: 12F, Zhongxing Industry Bld., Chuangye Rd., Nanshan District, Shenzhen, Guangdong
TEL: 86-755-2605 5363, 2605 5364; FAX: 86-755-2605 5365



<http://www.token.com.tw>



rfq@token.com.tw

Product Index

Information

●	General Information	01
---	---------------------------	----

RF Balun & SMD EMI Filters

●	TCB4F Series - SMD Common Mode Balun Transformers	03
●	TCB5F Series - Surface Mount RF Balun Transformer	09
●	TCB5FL Series - SMD Balun Transformer	13
●	TCPWC Series - EMI Filters SMD Common Mode Choke	16

Notice: Specification Changed or Version Updated will be posted at irregular intervals.
All Updated and Final Specifications, Please Confirm with TOKEN ELECTRONICS
REPRESENTATIVES.

✉ : rfq@token.com.tw

🏠 : <http://www.token.com.tw>

Surface Mount Balun Transformer General Information

What is Balun Transformer?

Balun is name of device that can be like a **common mode choke**, unbalance to balance transformer, or a step up or down transformer.

Balun is an acronym of **BAL**anced **UN**balanced, it's used to convert an unbalanced signal to a balanced one or vice versa. A balun transformer is a device that:

- joins a balanced line (one that has two conductors, with equal currents in opposite directions, such as a twisted pair cable).
- to an unbalanced line (one that has just one conductor and a ground, such as a coaxial cable).

Baluns isolate a transmission line and provide a balanced output. A typical use for a balun is in a television antenna.

Balanced: A method of transmitting signals using two signal lines. One line carries the source signal; the other carries a signal of opposite phase (antiphase).

Unbalanced: A method of transmitting signals using one signal line, with a ground line providing a reference potential.

Why Use a Balun?

Baluns are used for two primary reasons:

- One : Eliminate “common mode current” on the transmission line.
- Two : Matching antenna impedance to the transmission line.

Insertion Loss (dB)

Loss due to transmission from primary dot port to secondary dot port and secondary port. Most balun transformers are symmetrical through their central horizontal axis, therefore, an input can be applied at the primary dot port or the primary port with differential outputs at the secondary dot and secondary ports.

Basics of Broadband Transformers

There are two kinds of broadband transformers. One is known as a conventional type, which has separate primary and secondary windings, as do power and audio transformers. The other type is called a transmission-line transformer. It is believed that the latter variety is the most efficient of the two. Transmission-line transformers are wound with twisted or parallel windings and produce specific integers of impedance transformation, such as 4:1, 9:1, and 16:1. Conventional transformers permit you to obtain any transformation ratio you need.

Applications of Balun Transformers

In a **balun transformer**, one pair of terminals is balanced, that is, the currents are equal in magnitude and opposite in phase. The other pair of terminals is unbalanced; one side is connected to electrical ground and the other carries the signal. Balun transformers can be used between various parts of a wireless or cable communications system. Some common applications denotes as following:

- Television receiver (Balanced) - coaxial cable network or Coaxial antenna system (Unbalanced)
- FM broadcast receiver (Balanced) - Coaxial antenna system (Unbalanced)
- Dipole antenna (Balanced) - Coaxial transmission line (Unbalanced)
- Parallel-wire transmission line (Balanced) - Coaxial transmitter output, or Coaxial receiver input (Unbalanced)

Token's baluns provide impedance transformation in addition to conversion between balanced and unbalanced signal modes. Most television and FM broadcast receivers are designed for 300-ohm balanced systems, while coaxial cables have characteristic impedances of 50 or 75 ohms. Impedance-transformer baluns with larger ratios are available and used to match high-impedance balanced antennas to low-impedance unbalanced wireless receivers, transmitters, or transceivers.

SMD Common Mode Balun Transformers

SMD Common Mode Balun Transformers For USB - TCB4F Series

Surface Mount Common Mode Balun Transformer (TCB4F) For USB

► Preview

Token Electronics has introduced SMD common mode transformers (balun transformers) in 3.8 x 4.4 mm compact size, which are used to convert between unbalanced-balanced signals in the antenna inputs of tuner circuits for terrestrial digital broadcast compatible compact devices. Up to now balun transformers have been made by winding wire around a spectacle-shaped ferrite core, and are widely used in electronic devices such as TVs and desktop PCs.

Token SMD choke coils common mode TCB4F series are primarily designed for choking power lines and conform to the RoHS compliant and Lead-free. SMD TCB4F can be customized designs and tighter tolerances available on request.

Windings use paired or and triple wires for high uniformity. Base pins are end processed to allow direct mounting on PCB. Ideal for use in double balanced mixers, and as broad band transformers, transistors and for impedance conversion. Application of SMD choke coils specific designs also available including different inductance values and Q specifications adjusted to frequency requirements.

Token is equipped to design and produce custom components to meet many design and reliability demands. Custom parts are available on request. Token will also produce devices outside these specifications to meet specific customer requirements, please contact our sales for more information.

Features :

- Pair and triple wire coil for high stability and high balance.
- Available in tape & reel for automatic surface mounting..

Applications :

- Double Balance Mixers.
- Broad-Band Transformers.
- Impedance Transformers.
- Common Mode Filter, Balun Transformers.



www.token.com.tw

Configurations & Dimensions

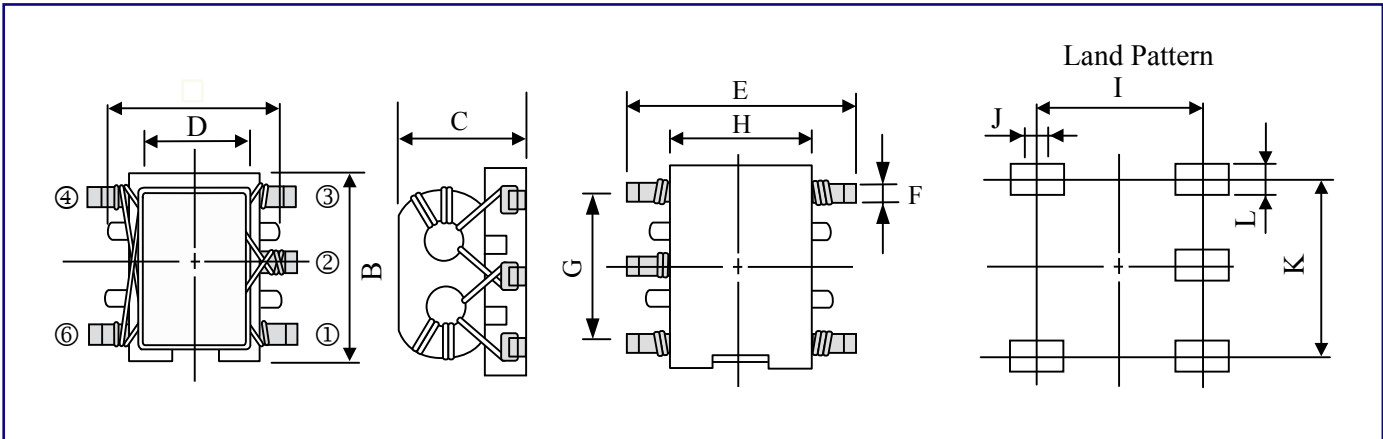

Type	A	B(max)	C(max)	D	E(max)	F	G	H	I	J	K	L
TCB4F	3.8	4.4	3.2	2.0	5.5	0.45	3.0	2.7	4.4	1.3	3.0	1.0

Note: Design as Customer's Requested Specifications.

(TCB4F - 617DB) Electrical Characteristics A

Part Number	Winding Turns 1-6=2-4=2-6=3-4	μiac
TCB4F - 617DB1673	2 1/2 T	300
TCB4F - 617DB1674	3 1/2 T	300
TCB4F - 617DB1675	4 1/2 T	300
TCB4F - 617DB1714	5 1/2 T	300

(TCB4F - 617DB) Test Circuit A

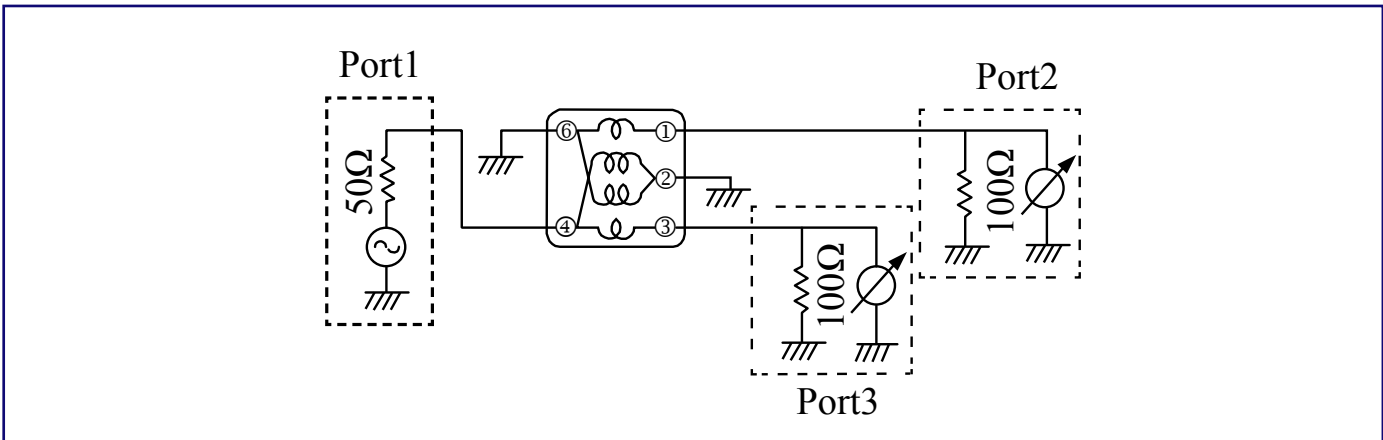

▶ (TCB4F - 617DB) Typical Characteristics A

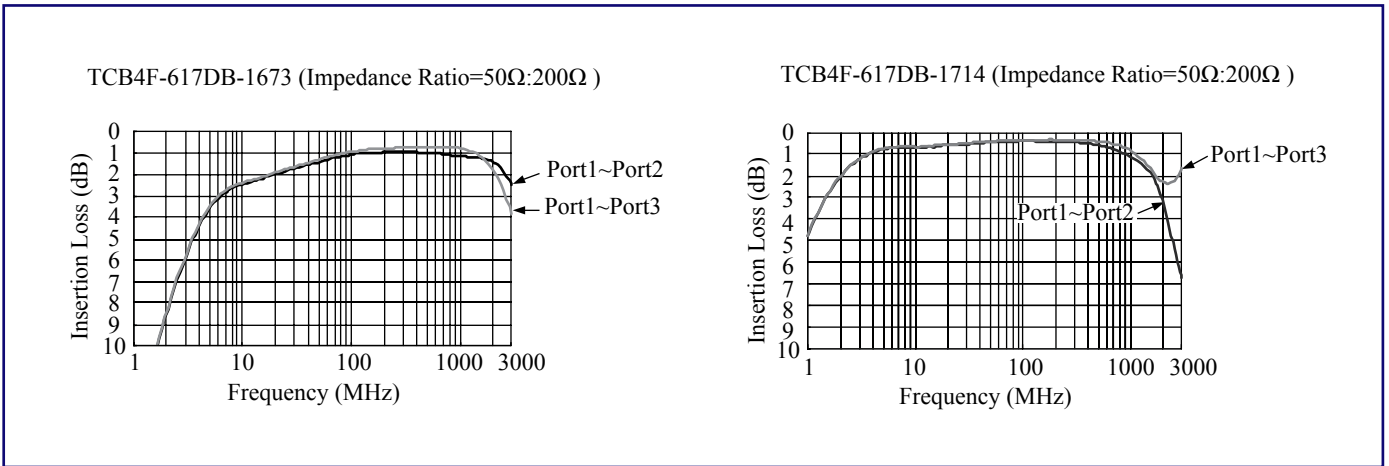

▶ (TCB4F - 617DB) Electrical Characteristics B

Part Number	Winding Turns	μiac
TCB4F - 617DB1653	2 1/2 T	300
TCB4F - 617DB1654	3 1/2 T	300
TCB4F - 617DB1655	4 1/2 T	300
TCB4F - 617DB1724	5 1/2 T	300

▶ (TCB4F - 617DB) Test Circuit B

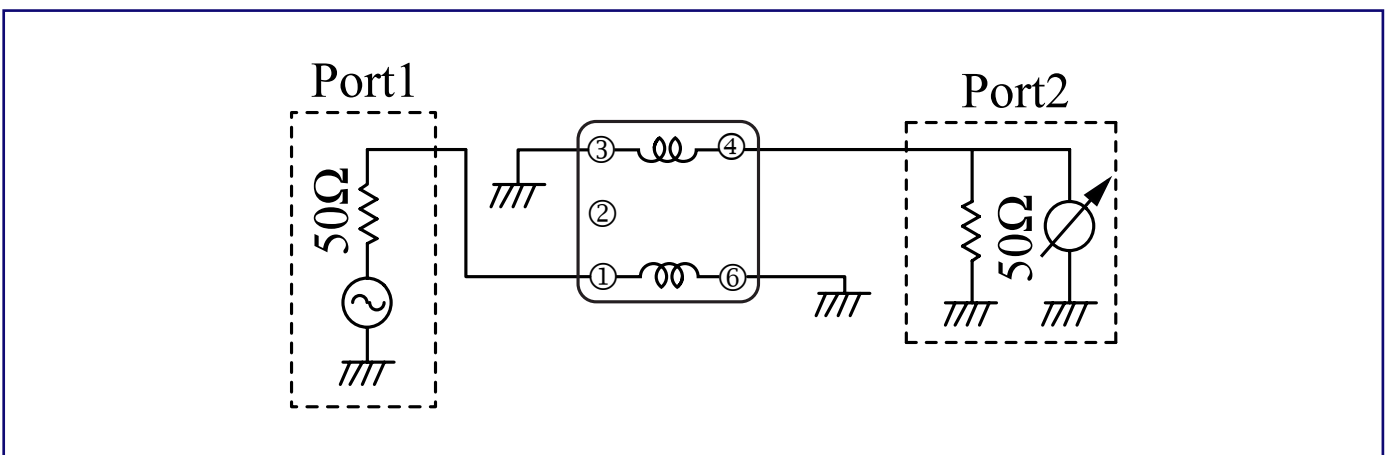

(TCB4F - 617DB) Typical Characteristics B

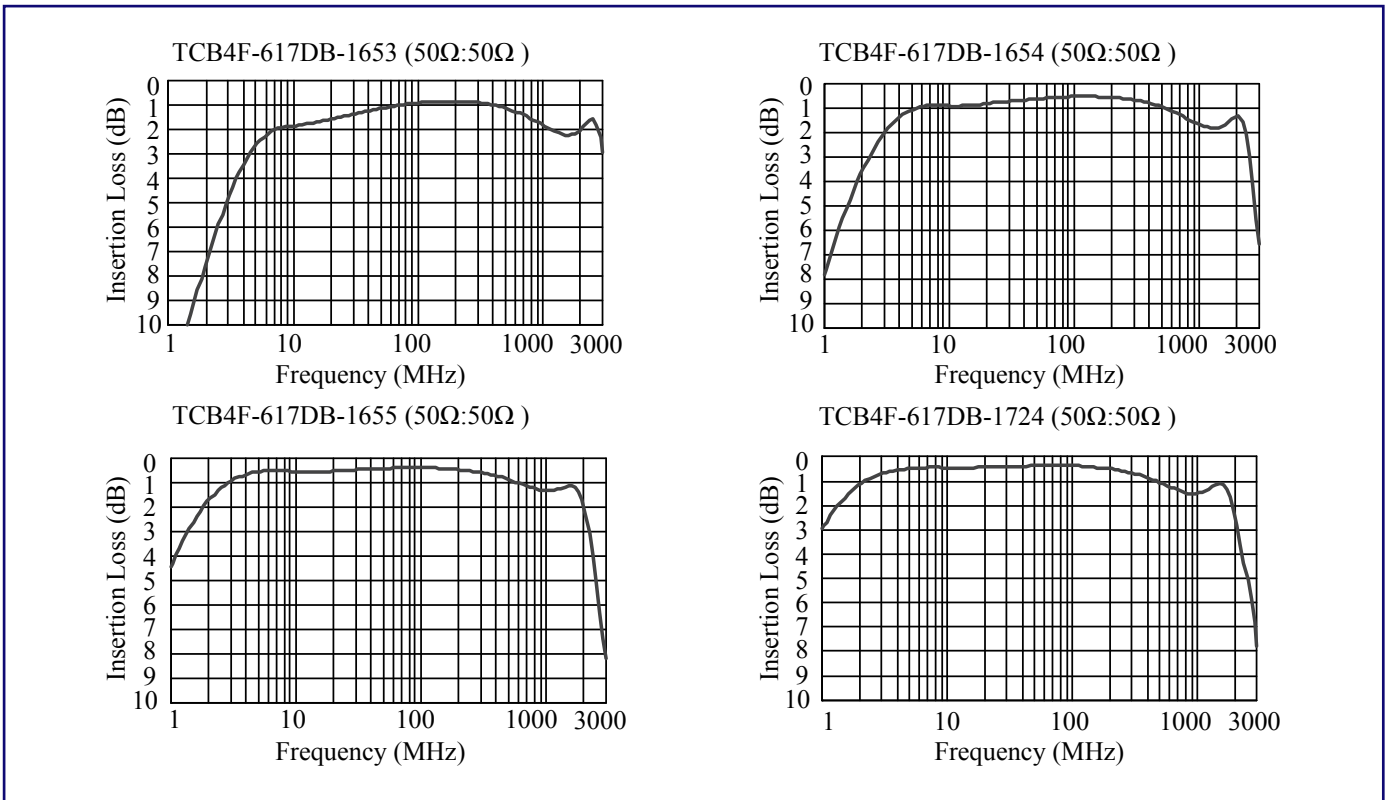

(TCB4F - 617DB) Electrical Characteristics C

Part Number	Winding Turns	μiac
TCB4F - 617DB1643	2 1/2 T	1500
TCB4F - 617DB1644	3 1/2 T	1500
TCB4F - 617DB1645	4 1/2 T	1500
TCB4F - 617DB1646	5 1/2 T	1500

(TCB4F - 617DB) Electrical Characteristics C

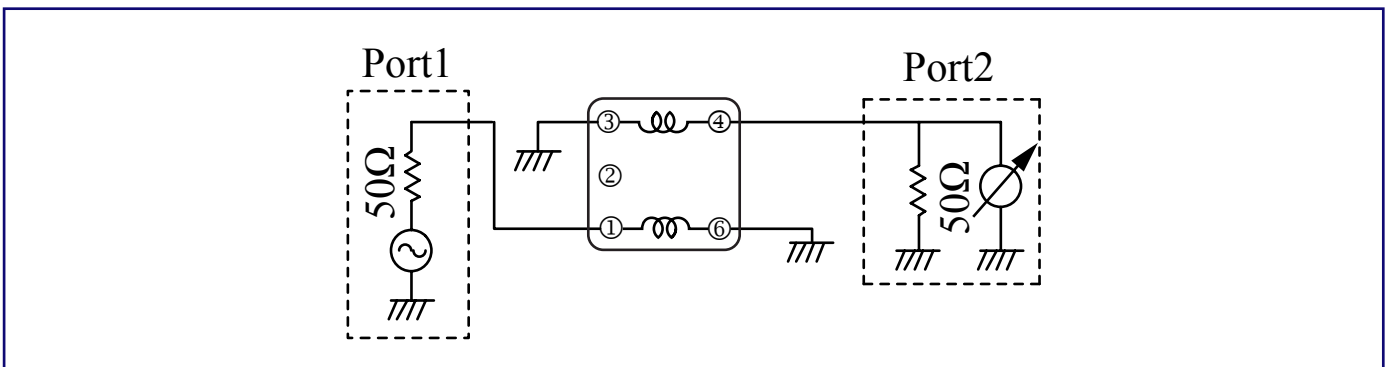

▶ (TCB4F - 617DB) Typical Characteristics C

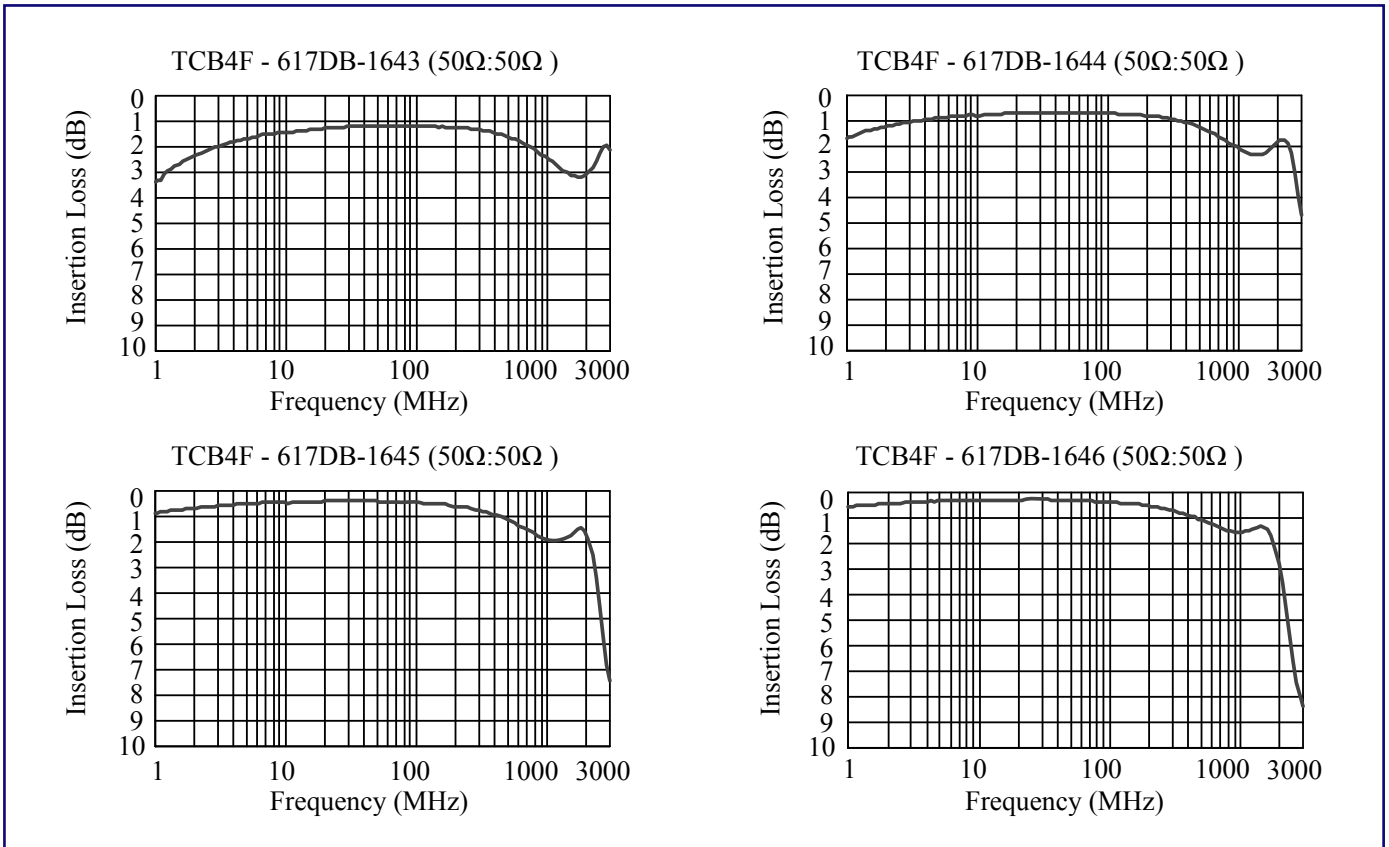

▶ (TCB4F - 617PT) Electrical Characteristics

Part Number	Winding Turns 1-2=2-3=4-6	μiac
TCB4F - 617PT1667	2T	300
TCB4F - 617PT1669	3T	300
TCB4F - 617PT1699	4T	300
TCB4F - 617PT1664	5T	300

▶ (TCB4F - 617PT) Test Circuit

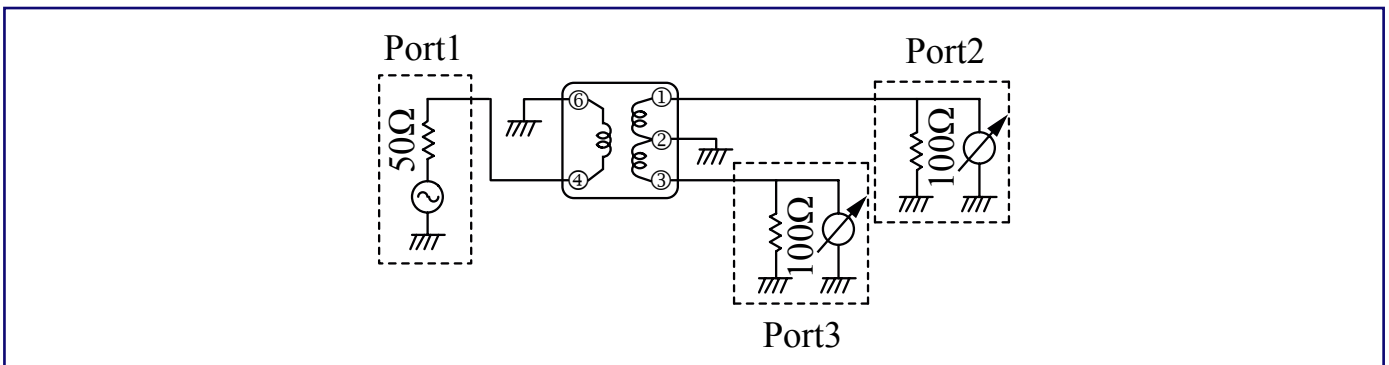

▶ (TCB4F - 617PT) Typical Characteristics

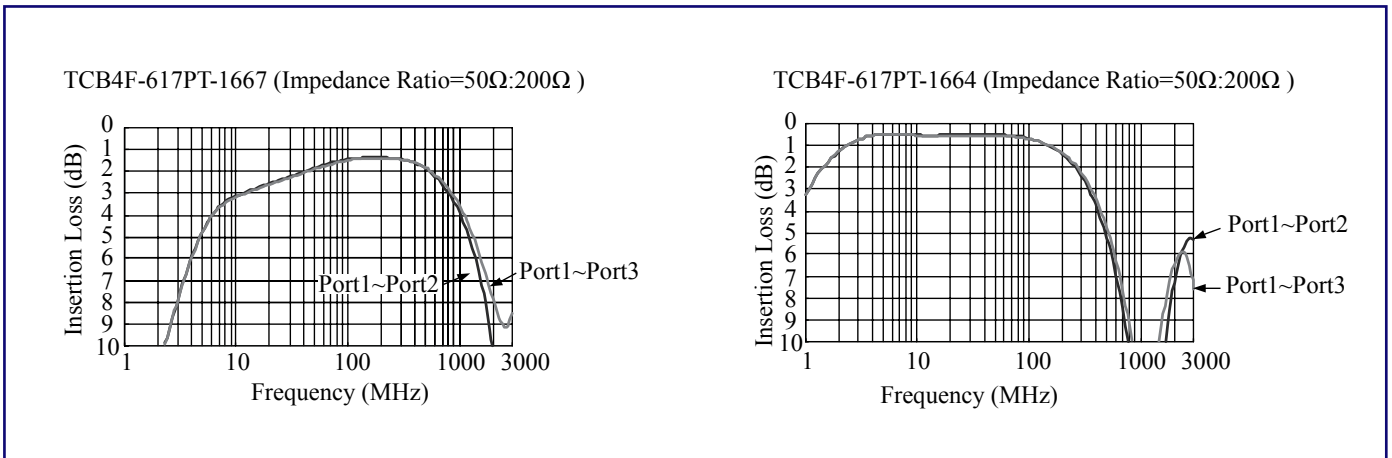

▶ How to Order

TCB4F

❶

617DB1673

❷

❶ Part Number: TCB4F

❷ Type

Code	Type
617DB1673	Frequency mixer
617PT1667	Frequency mixer
617DB1653	Balun Transformers
617DB1643	Balun Transformers

Back to 1st Page - SMD Common Mode Balun Transformers (TCB4F)

Surface Mount RF Balun Transformers

Surface Mount RF Balun Transformer (TCB5F) Common Mode

► Preview

Token utilizes the latest winding technology using paired wires for high uniformity and enabling the most cost-effective designs in manufacturing common mode surface mount RF balun transformer products.

Base pins are end processed to allow direct mounting on PCB. Ideal for use in double balanced mixers, and as broad band transformers, transistors and for impedance conversion.

Token RF Balun Transformer TCB5F series are primarily designed for choking power lines and conform to the RoHS compliant and Lead-free. SMD TCB5F feature with ultra-compact size, wide inductance selection, and low-resistance coils. SMD choke coils can be customized designs and tighter tolerances available on request.

Application of Balun Transformer specific designs also available including different inductance values and Q specifications adjusted to frequency requirements.

Token is equipped to design and produce custom components to meet many design and reliability demands. Custom parts are available on request. Token will also produce devices outside these specifications to meet specific customer requirements, please contact our sales for more information.

Features :

- Pair wire coil for high stability.

Applications :

- Double Balance Mixers, Broad-Band Transformers;
- Impedance Transformers, Balun Transformers.



www.token.com.tw

Configurations & Dimensions

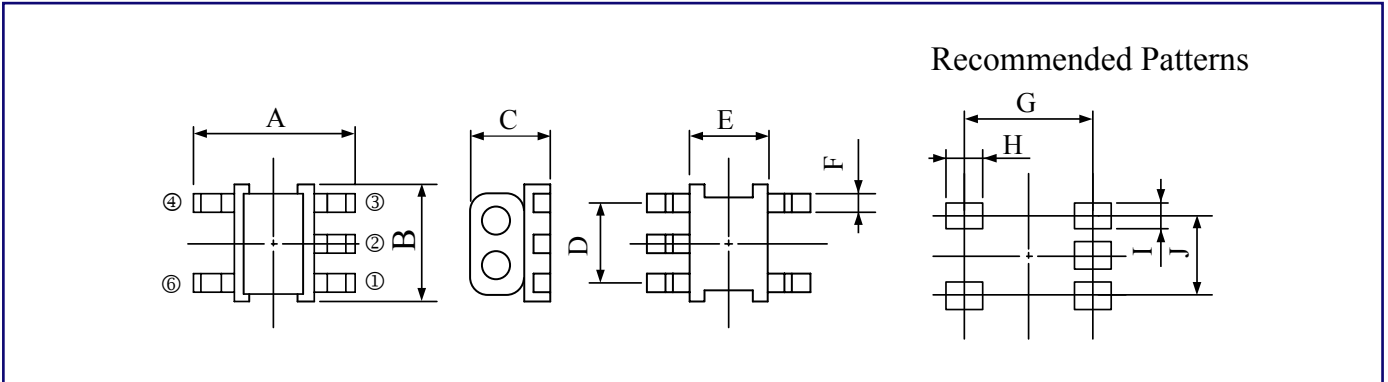

Type	A (max)	B (max)	C (max)	D	E	F	G	H	I	J
TCB5F	6.9	6.9	4.4	4.0	3.8	0.6	5.7	1.7	1.2	4.0

Note: Design as Customer's Requested Specifications.

(TCB5F - 458DB) Electrical Characteristics

Part Number	Winding Turns 1-6=2-4=2-6=3-4	μiac
TCB5F - 458DB1614	2 1/2 T	300
TCB5F - 458DB1615	3 1/2 T	300
TCB5F - 458DB1616	4 1/2 T	300

(TCB4F - 617DB) Test Circuit A

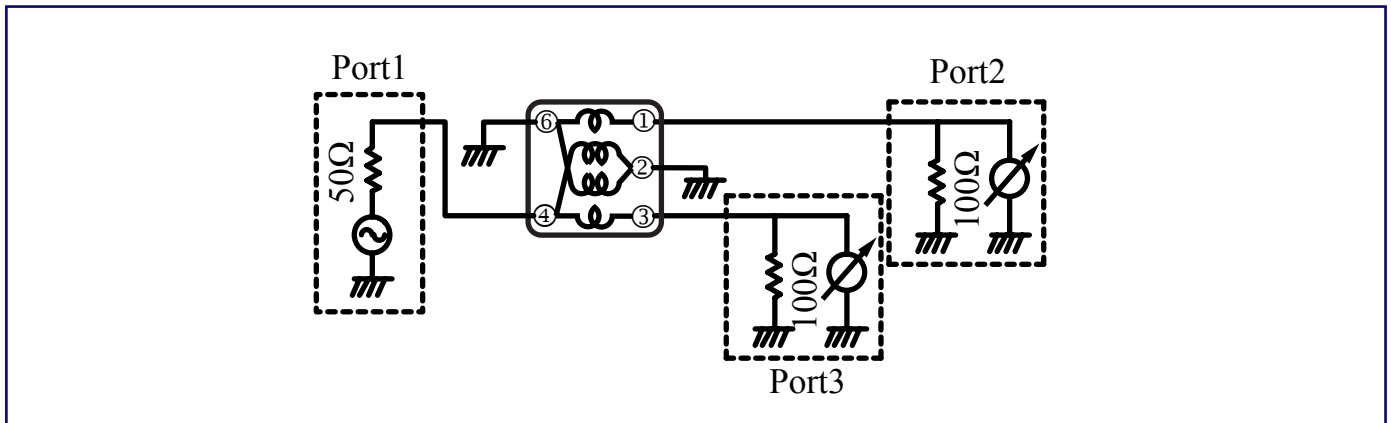

▶ (TCB5F - 458DB) Typical Characteristics

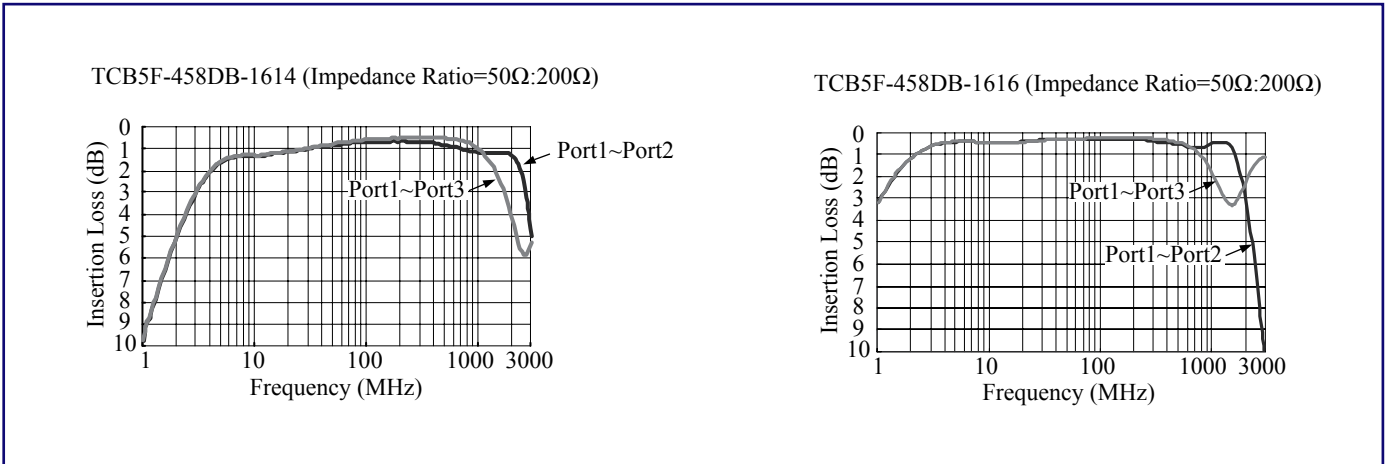

▶ (TCB4F - 617DB) Electrical Characteristics B

Part Number	Winding Turns 1-2=2-3=4-6	μiac
TCB5F - 458PT1619	2 T	300
TCB5F - 458PT1586	3 T	230
TCB5F - 458PT1587	4 T	230
TCB5F - 458PT1565	5 T	230

▶ (TCB5F - 458PT) Test Circuit

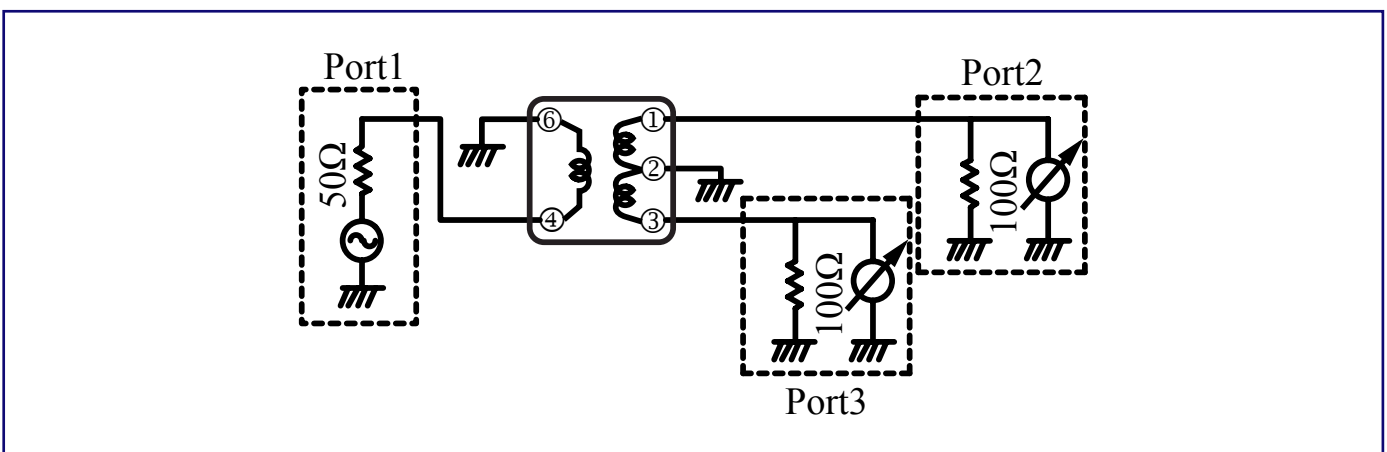

▶ (TCB5F - 458PT) Typical Characteristics

TCB5F-458PT-1619 (Impedance Ratio=50Ω:200Ω)

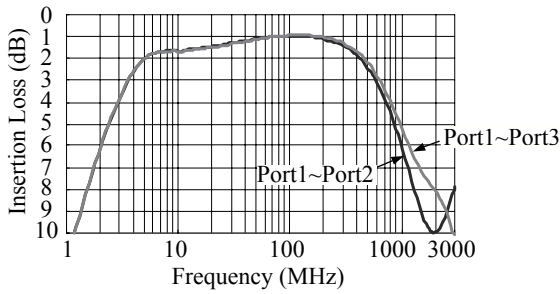

TCB5F-458PT-1586 (Impedance Ratio=50Ω:200Ω)

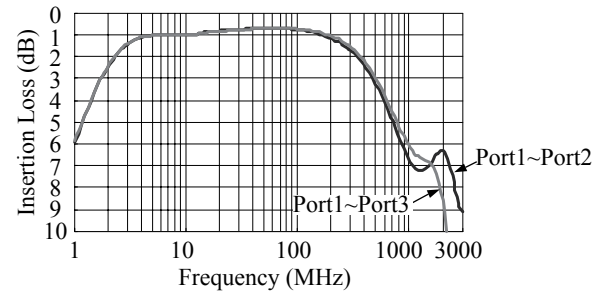

TCB5F-458PT-1587 (Impedance Ratio=50Ω:200Ω)

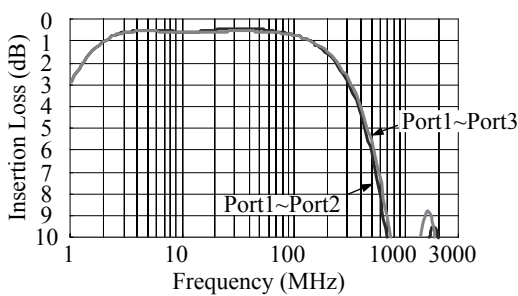

TCB5F-458PT-1565 (Impedance Ratio=50Ω:200Ω)

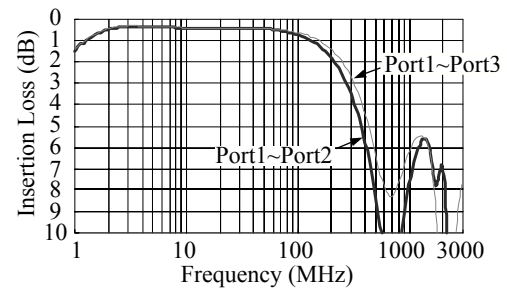

▶ How to Order

TCB5F

❶

458DB1614

❷

❶ Part Number: TCB4F

❷ Type

Code	Type
458DB1614	Frequency mixer
458DB1615	Frequency mixer
458PT1619	Frequency mixer
458PT1586	Frequency mixer

Back to 1st Page - Surface Mount RF Balun Transformer (TCB5F)

SMD Balun Surface Mount Transformer

SMD Balun Transformer (TCB5FL) Common Mode

► Preview

A Balun is a device which converts balanced impedance to unbalanced and vice versa. In addition, baluns can also provide impedance transformation, hence the name Balun Transformers.

Token utilizes the latest winding technology using paired wires for high uniformity and enabling the most cost-effective designs in manufacturing SMD balun transformer products.

Token SMD common mode TCB5FL balun transformer series are primarily designed for choking power lines and conform to the RoHS compliant and Lead-free. SMD TCB5FL feature with ultra-compact size, wide inductance selection, and low-resistance coils. SMD TCB5FL can be customized designs and tighter tolerances available on request.

Application of SMD balun transformer specific designs also available including different inductance values and Q specifications adjusted to frequency requirements. Base pins are end processed to allow direct mounting on PCB. Ideal for use in double balanced mixers, and as broad band transformers, transistors and for impedance conversion.

Token will also produce devices outside these specifications to meet customer requirements, with comprehensive application engineering and design support available for customers worldwide.

Features :

- Pair wire coil for high stability.

Applications :

- Double Balance Mixers, Broad-Band Transformers;
- Impedance Transformers, Balun Transformers , etc..



www.token.com.tw

Configurations & Dimensions

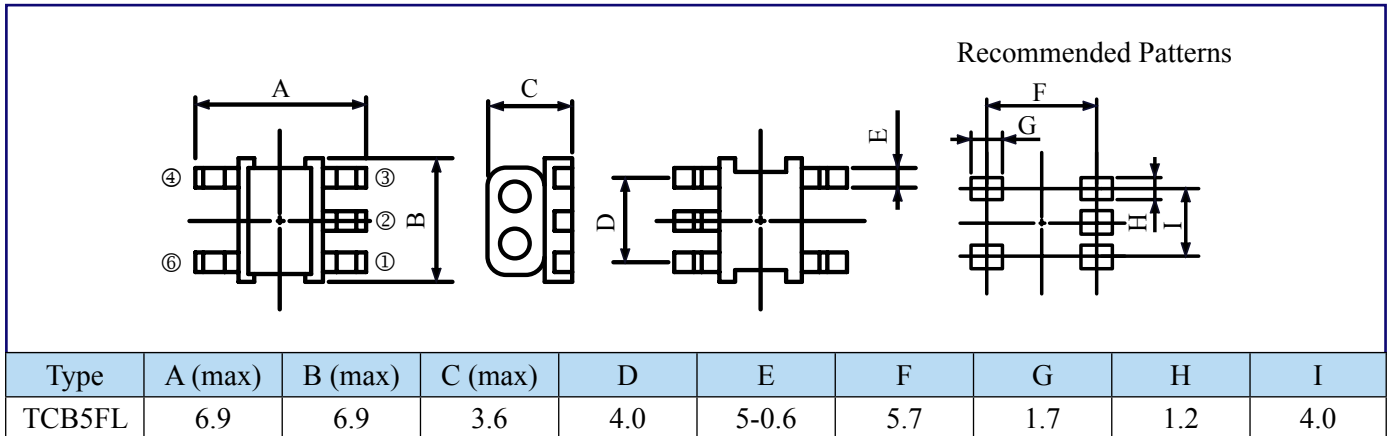

Note: Design as Customer's Requested Specifications.

(TCB5FL) Common Mode Electrical Characteristics

Part Number	Winding Turns 1-6=2-4=2-6=3-4	μiac
TCB5FL - 616DB1196	2 1/2 T	300
TCB5FL - 616DB1197	3 1/2 T	300
TCB5FL - 616DB1198	4 1/2 T	300

(TCB4F - 617DB) Test Circuit A

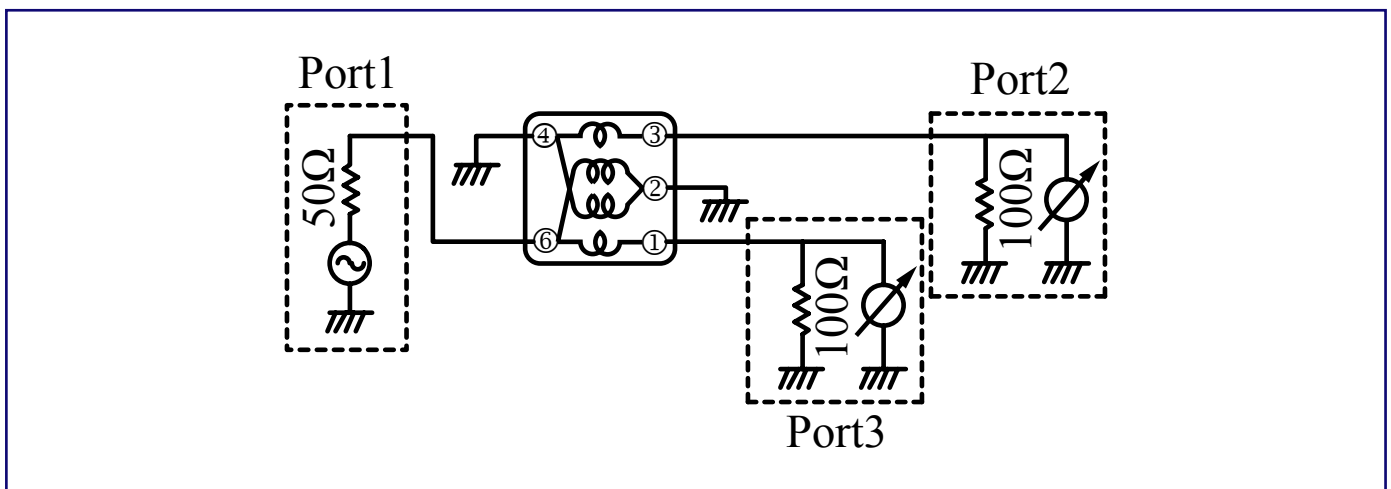

▶ (TCB5F - 458DB) Typical Characteristics

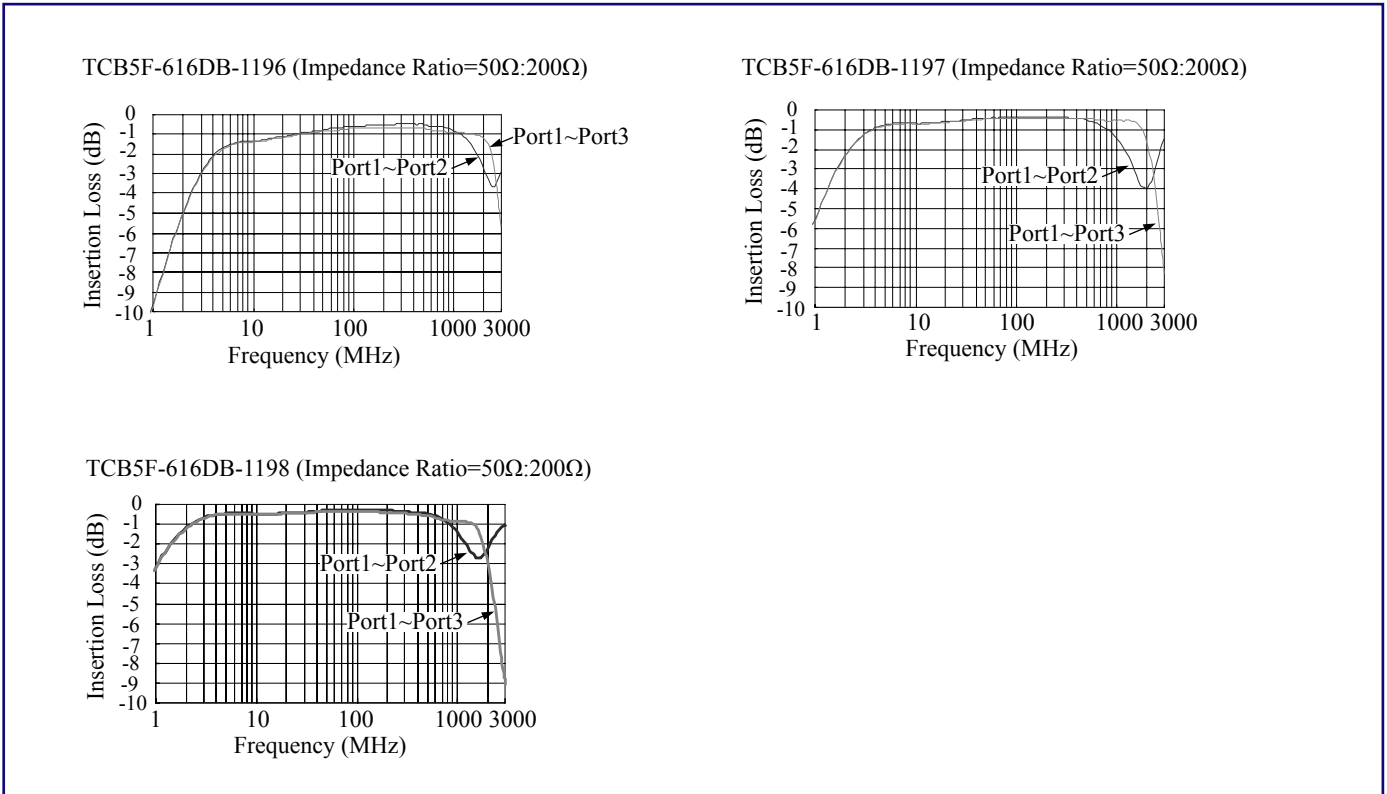

▶ How to Order

TCB5F

❶

616DB1196

❷

❶ Part Number: TCB5FL

❷ Type

Code	Type
616DB1196	Frequency mixer
616DB1197	Frequency mixer

Back to 1st Page - SMD Balun Transformer (TCB5FL) Common Mode

SMD EMI Filters Common Mode Choke



www.token.com.tw

▶ Preview

Token EMI filters SMD common mode choke TCPWC series are primarily designed for choking power lines and conform to the RoHS compliant and Lead-free. SMD choke EMI filters feature with ultra-compact size, wide inductance selection, and low-resistance coils. SMD TCPWC can be customized designs and tighter tolerances available on request.

Token's TCPWC taking advantage of the latest winding technology consists ferrite core and a pair lines enabling the most effective in noise suppression designs. Feature high common-mode impedance at noise band and low differential-mode impedance at signal band. Low differential-mode impedance with high coupling factor, there is almost no distortion on high speed signal.

Application of SMD choke EMI filters specific designs also available including different inductance values and Q specifications adjusted to frequency requirements.

Token will also produce devices outside these specifications to meet customer requirements, with comprehensive application engineering and design support available for customers worldwide.

Applications :

- USB Line for Personal Computers and Peripheral.
- IEEE 1394 Line for Personal Computers ,DVC ,STB.
- LCD Panels. Low-Voltage Differential Signal (LVDS).
- EMI Radiation Noise Suppression for Any Electronic Device.

Configurations & Dimensions

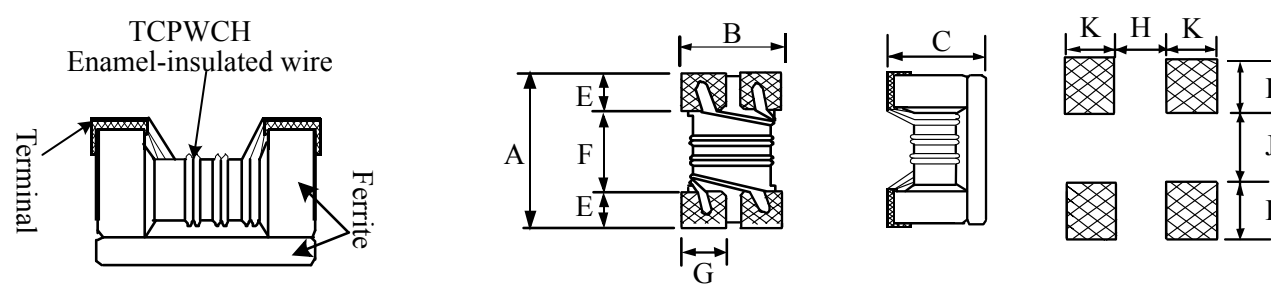

TYPE	A	B	C	E	F	G	H	I	J	K
TCPWCH05	2.0±0.2	1.2±0.2	1.2±0.2	0.45	1.2	0.4	0.8	0.4	0.4	0.90
TCPWCH06	3.2±0.2	1.6±0.2	1.8±0.2	0.60	2.0	0.6	1.6	0.6	0.4	1.05

Electrical Characteristics

Part Number	Impedance (Ω) 100MHz	DCR (Ω)(max)	Rated Current (mA)(max)	Rated Voltage (V)(DC)	Withstanding Voltage (V)(DC)	Insulation Resistance (MΩ)(min)
TCPWCH05MT670	67	0.25	400	50	125	10
TCPWCH05MT900	90	0.35	330	50	125	10
TCPWCH05MT121	120	0.30	370	50	125	10
TCPWCH05MT181	180	0.35	330	50	125	10
TCPWCH05MT201	200	0.35	330	50	125	10
TCPWCH05MT261	260	0.40	300	50	125	10
TCPWCH05MT371	370	0.40	280	50	125	10
TCPWCH06MT900	90	0.30	370	50	125	10
TCPWCH06MT161	160	0.40	340	50	125	10
TCPWCH06MT261	260	0.50	310	50	125	10
TCPWCH06MT601	600	0.80	260	50	125	10
TCPWCH06MT102	1000	1.00	230	50	125	10
TCPWCH06MT222	2200	1.20	200	50	125	10

Note: Operating Temp.: -40°C+85°C.

► Packaging Quantity & Reel Specifications

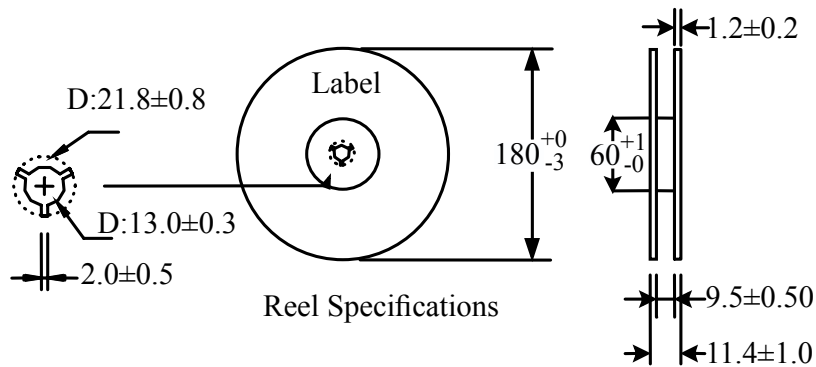

Type	Emboss Plastic Tape (PCS)
TCPWCH05	2000
TCPWCH06	2000

► Emboss Plastic Tape Specifications

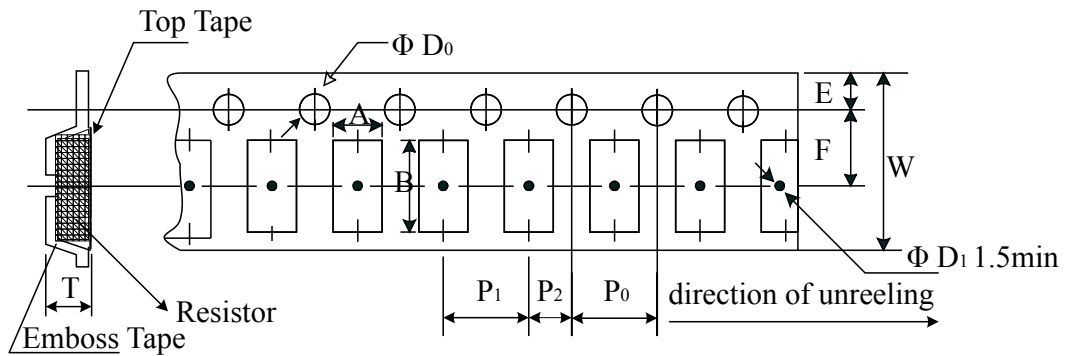

Codes	A	B	W	E	F	P0	P1	P2	ΦD0	t
TCPWCH05	±0.10	±0.05	±0.20	±0.10	±0.10	±0.10	±0.10	±0.10	+0.10	±0.10
TCPWCH05	1.40	2.55	8.0	1.75	3.5	4.00	4.00	2.00	1.50	1.35
TCPWCH06	1.90	3.50	8.0	1.75	3.5	4.00	4.00	2.00	1.50	2.10

▶ Leader / Tape

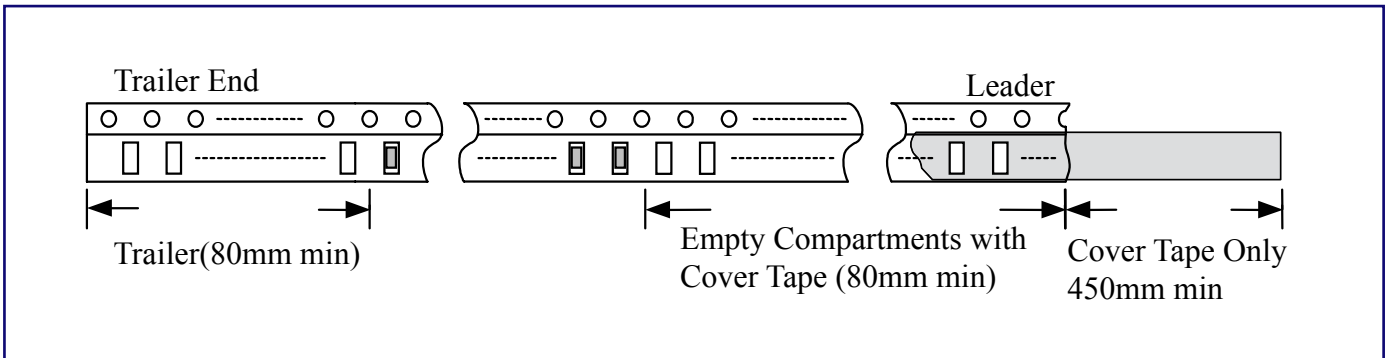

▶ Peel-off Force

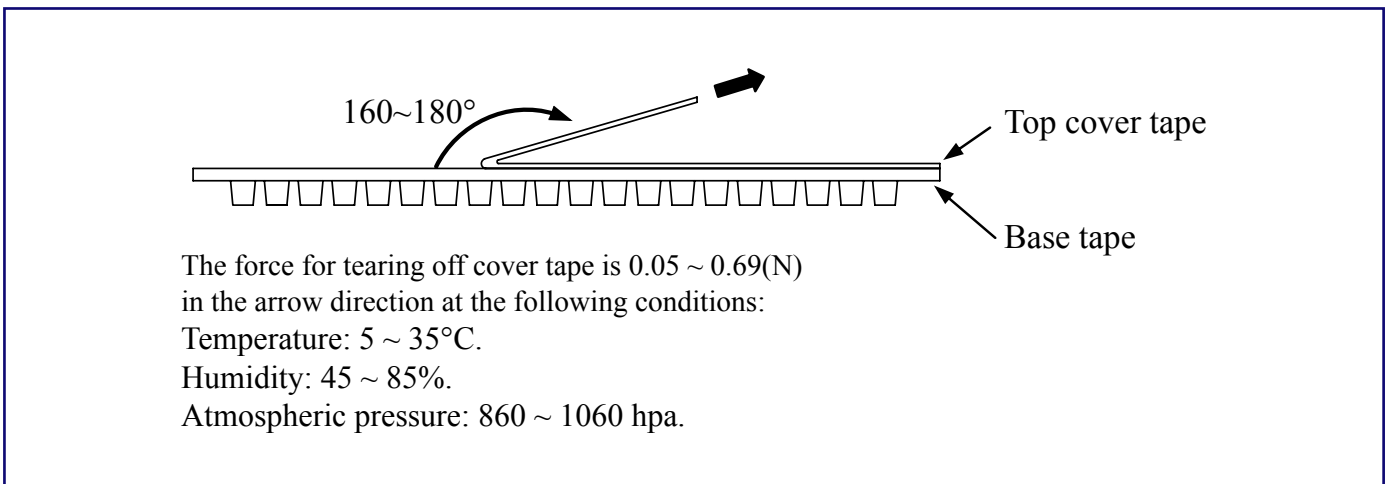

▶ (TCB4F - 617DB) Electrical Characteristics C

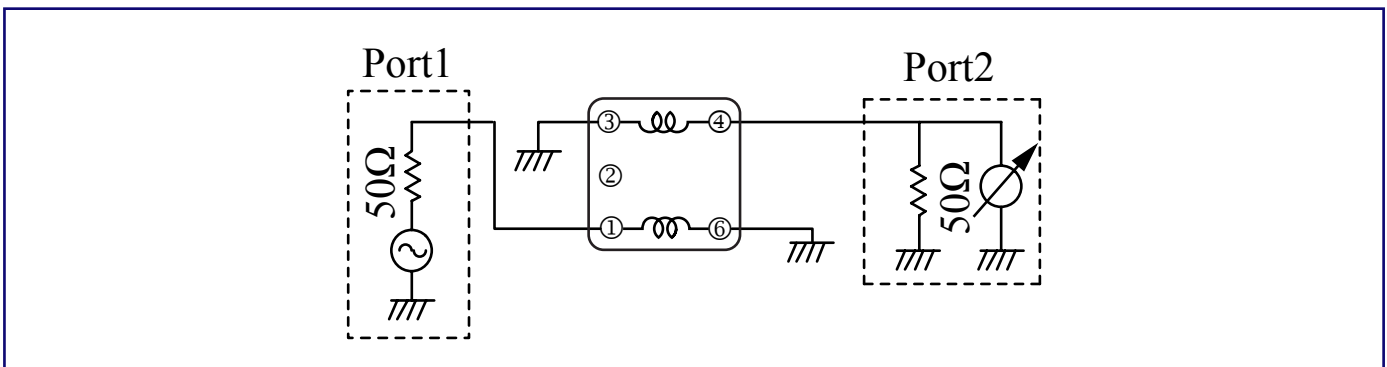

▶ How to Order

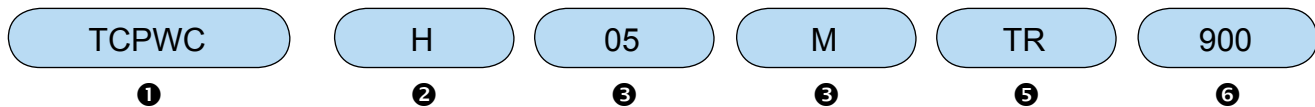

❶ Part Number: TCPWCH05, TCPWCH06

❷ Shielding Type

Code	Shielding Type
H	Shielding

❸ Dimensions (L×W) (mm)

Code	Dimensions(L×W)	EIA
05	2.10×1.20	EIA0805
06	3.20×1.50	1206

❹ Impedance Tolerance: M (±20%)

❺ Packaging

Code	Packaging
TR	Taping Reel
p	Bulk

❻ Impedance

Code	Impedance
900	90Ω
121	120Ω
102	1000Ω
222	2200Ω