

12	13	14	15
MAPX	MODIFICATION	DATE	DRAW

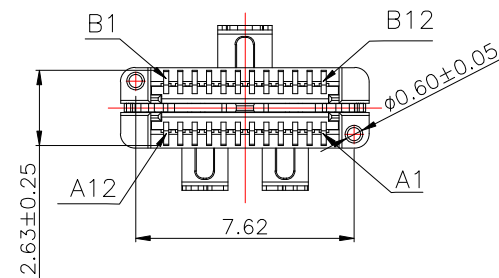
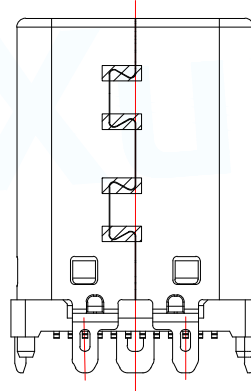
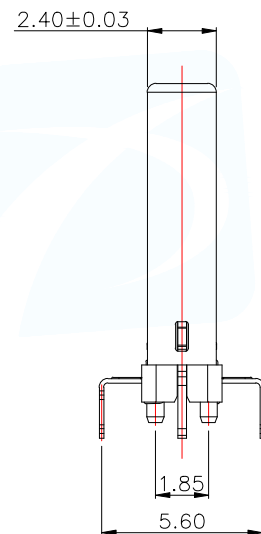
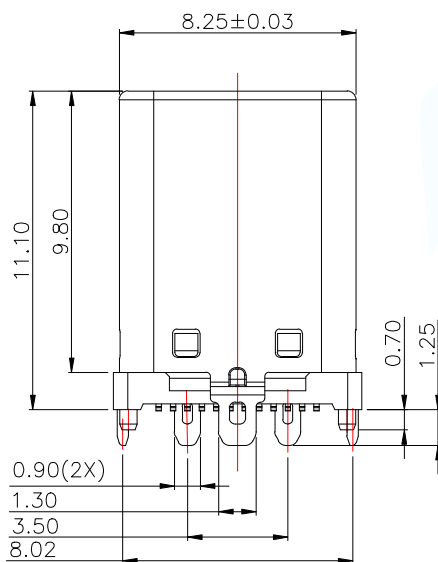
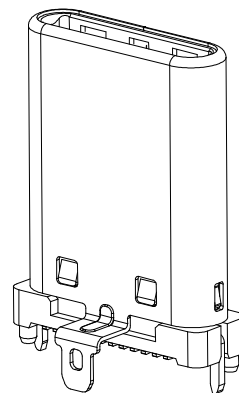
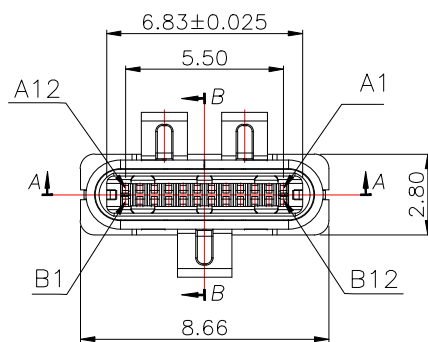

NOTE:

- MATERIAL SPECIFICATION:
 - HOUSING&PICKUP COVER:LCP,UL94 V-0.BLACK
 - CONTACTS:SEE TABLE 1
 - LATCH: STAINLESS STEEL(SUS301)
 - SPRING: STAINLESS STEEL(SUS304)
 - FRONT SHELL: STAINLESS STEEL(SUS304)
- PLATING SPECIFICATION:
 - CONTACTS:
 - Ni 50u" MIN. UNDER PLATED OVER ALL.
 - Au PLATED ON THE FUNCTIONAL AREA OF CONTACT. (GOLD PLATING THICKNESS FOLLOW THE P/N)
 - PLATING SPECIFICATIONS OF THE SOLDER AREA FOLLOW THE P/N
 - FRONT SHELL:
 - Ni 30u" MIN. UNDER PLATED OVER ALL.
 - LATCH:
 - Ni 50u" MIN. UNDER PLATED OVER ALL.
 - 80u" MIN. TIN PLATED ON SOLDER AREA.
 - SPRING:
 - CLEAR ONLY
- MECHANICAL PERFORMANCE,
 - INSERTION FORCE: 0.5~2.0kgf.
 - REMOVAL FORCE: 0.8kgf~2.0kgf.
 - DURABILITY: 10000 CYCLES.
- ELECTRICAL PERFORMANCE,
 - CURRENT RATING:SEE TABLE 1
VOLTAGE RATING:5.0V
 - LLCR:
 - VBUS & GND PINS AND OTHER PINS: 40mA/PIN MAX.
 - SHIELD: 50mA/MAX.
 - LLCR MAX. CHANGE OF ALL PINS: 10mA.
 - INSULATION RESISTANCE: 100MΩ MIN
 - DIELECTRIC WITHSTAND VOLTAGE,AC 100V FOR 1 MINUTE.
- ENVIRONMENTAL PERFORMANCE:
 - OPERATING TEMPERATURE: -25°C~+85°C.
- IR REFLOW:
 - THE PEAK TEMPERATURE ON THE BOARD SHALL BE MAINTAINED FOR 10 SECONDS AT 260°C.

MANUFACTURE DWG			 东莞市讯普电子科技有限公司 DongGuan XunPu Electronics Co.,Ltd	
UNLESS OTHERWISE SPECIFIED TOLERANCES			TITLE: USB CM VERTICAL TYPE HIGHT=11.1	
DECIMALS:	ANGLES:	PAR	TYPEC-952-ACP24	
.X:±0.30	X':±10°	DWN		
.XX:±0.20	.X':±8°	CHKD		
.XXX:±0.10	.XX':±5°	APVD		
CUSTOMER COPY		SCALE1:1	UNIT:MM	
		SIZE:A4	SHEET:1F1	REV:A

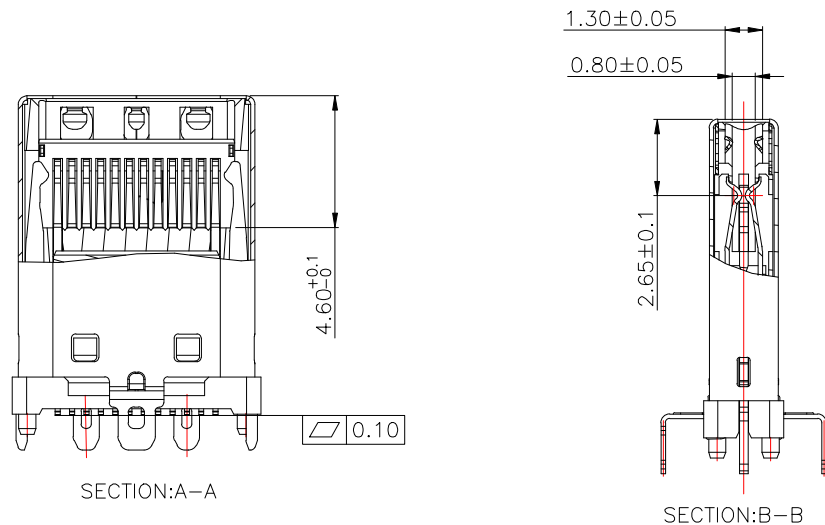

USB TYPE-C PIN ASSIGNMENTS

PIN NUMBER	SIGNAL NAME	PIN NUMBER	SIGNAL NAME
A1	GND	B12	GND
A2	SSTXp1	B11	SSRXp1
A3	SSTXn1	B10	SSRXn1
A4	Vbus	B9	Vbus
A5	CC1	B8	SBU2
A6	Dp1	B7	Dn2
A7	Dn1	B6	Dp2
A8	SBU1	B5	CC2
A9	Vbus	B4	Vbus
A10	SSRXn2	B3	SSTXn2
A11	SSRXp2	B2	SSTXp2
A12	GND	B1	GND

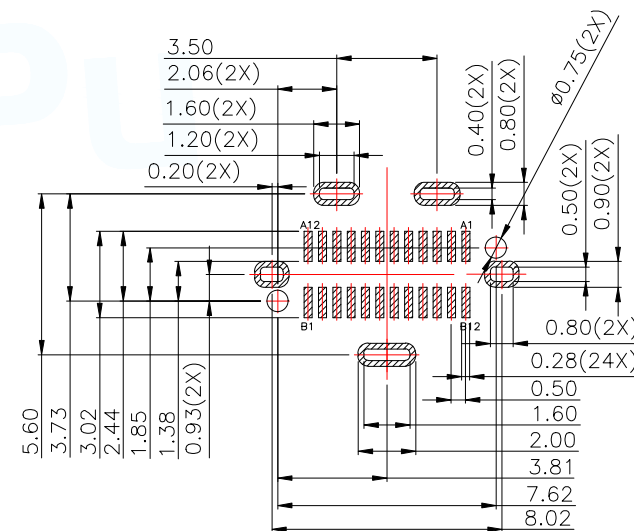
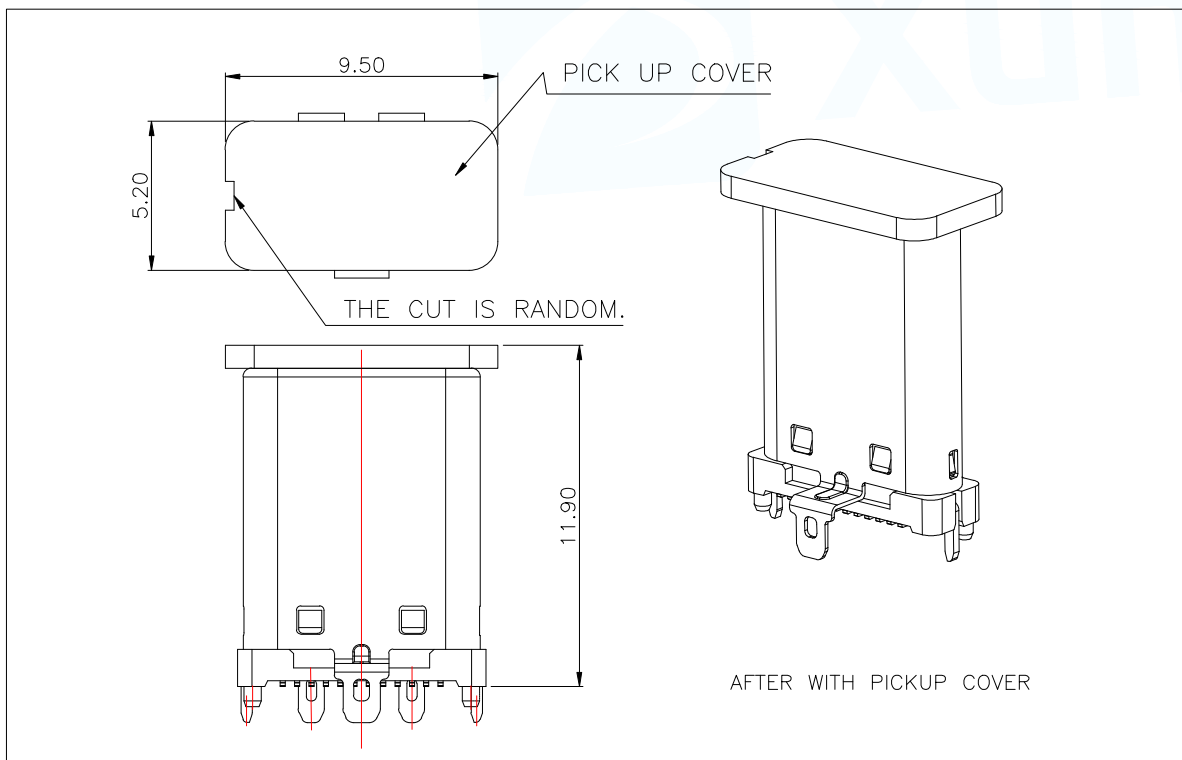

RECOMMENDED PCB LAYOUT(TOP VIEW)
THICKNESS 0.8±0.10MM;DEFAULT TOLERANCE:±0.05

MANUFACTURE DWG		 东莞市讯普电子科技有限公司 DongGuan XunPu Electronics Co.,Ltd	TITLE: USB CM VERTICAL TYPE HIGHT=11.1	
UNLESS OTHERWISE SPECIFIED TOLERANCES			PAR	TYPEC-952-ACP24
DECIMALS:	ANGLES:	DWN		
.X:±0.30	X':±10°	CHKD		
.XX:±0.20	.X':±8°	APVD		
.XXX:±0.10	.XX':±5°	SCALE1:1	UNIT:MM	
		SIZE:A4	SHEET:1F1	
		CUSTOMER COPY	REV:A	

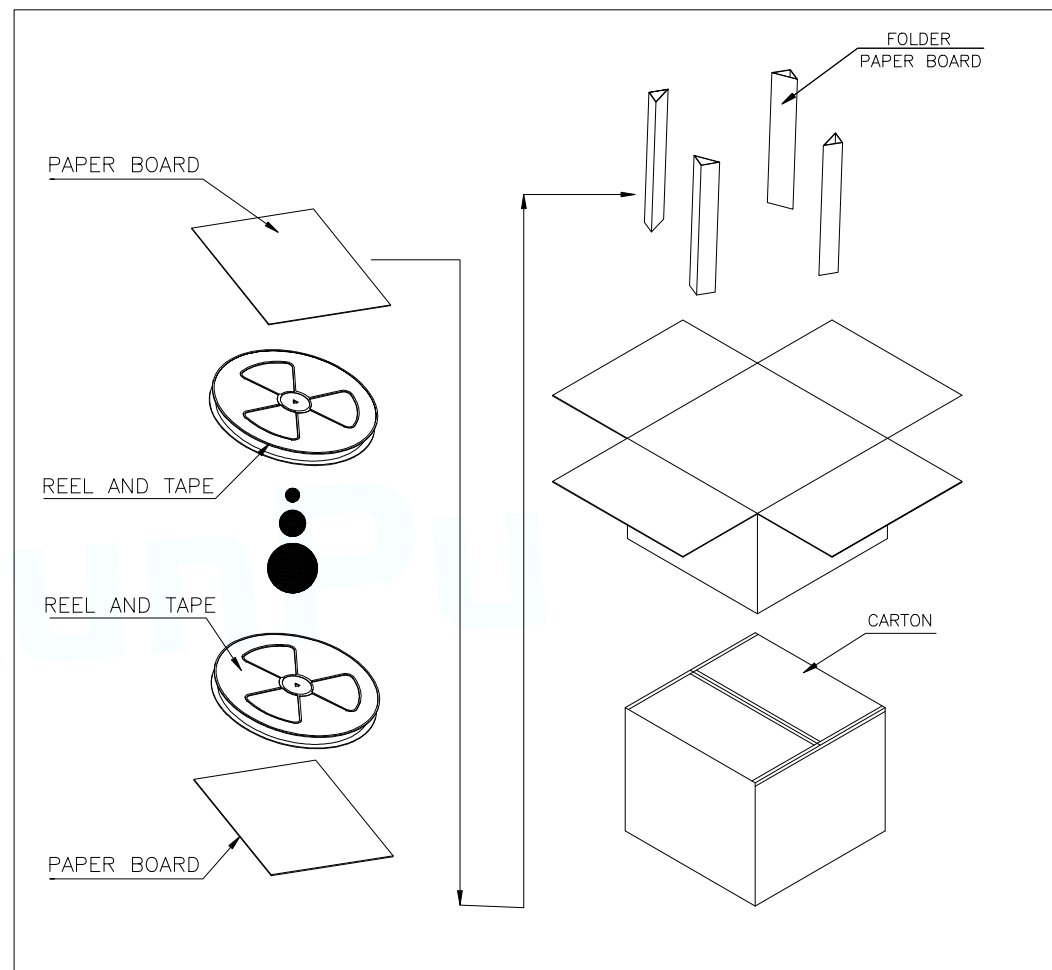
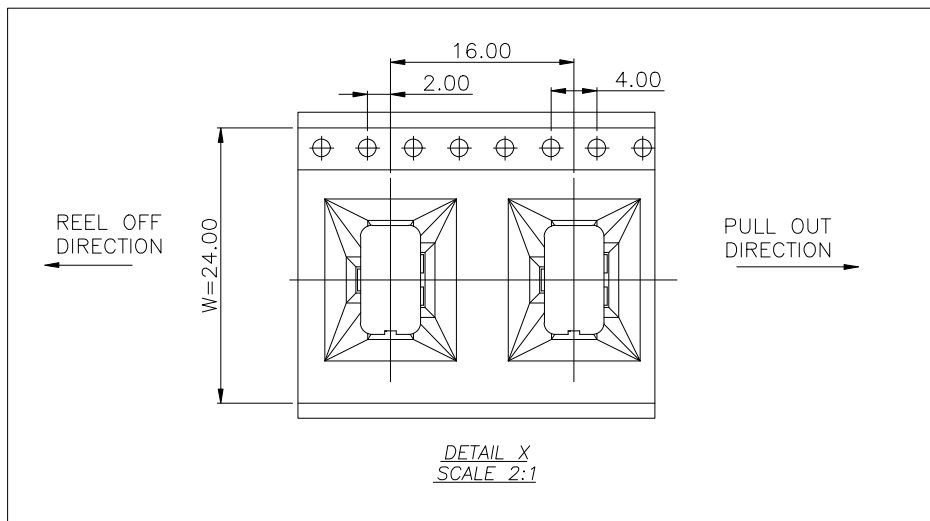
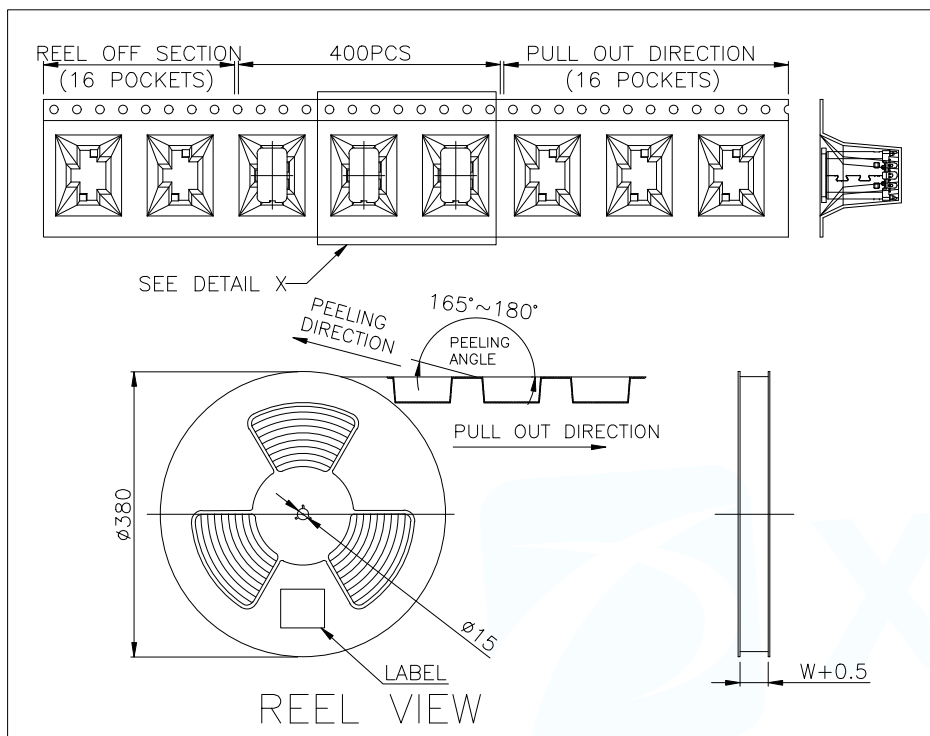

	REEL/TRAY	CARTON
CONNECTOR (PCS)	400	4000

MANUFACTURE DWG			 东莞市讯普电子科技有限公司 DongGuan XunPu Electronics Co.,Ltd	
UNLESS OTHERWISE SPECIFIED TOLERANCES			TITLE: USB CM VERTICAL TYPE HIGHT=11.1	
DECIMALS:	ANGLES:	PAR	TYPEC-952-ACP24	
.X:±0.30	X':±10°	DWN		
.XX:±0.20	.X':±8°	CHKD		
.XXX:±0.10	.XX':±5°	APVD		
CUSTOMER COPY		SCALE1:1	UNIT:MM	
		SIZE:A4	SHEET:1F1	REV:A