

Size: 0.72in x 0.58in x 0.28in (18.20mm x 14.80mm x 7.10mm)

FEATURES

- Single Channel
- Compact Size
- CAN Isolation Transceiver Module
- Two-Port Isolation: 3.0kVDC
- High Baud Rate Up to 1Mbps
- RoHS Compliant
- Bus Can Support Maximum 110 Nodes
- DIP8 Package
- Set Isolation and ESD Bus Protection In One
- EN60950 Safety Approval
- 3 Year Warranty

DESCRIPTION

The RBCAND21 series of CAN isolation transceiver module is a single channel, high speed, industrial bus that converts TTL/CMOS level to CAN bus differential level and uses IC integrated technology to achieve signal and power isolation. This series consists of very compact models with a DIP8 package and a bus that can support a maximum of 110 nodes. It features two-port isolation of 3.0kVDC, baud rate up to 1Mbps, as well as set isolation and ESD bus protection in one. This series is RoHS compliant and also has EN60950 safety approvals.

MODEL SELECTION TABLE

Model Number	Input Voltage	Static Current	Max. Operating Current	Bus Maximum Voltage	Baud Rate	Number of Nodes	Certification
RBCAND21-3100	3.3VDC	29mA	100mA	±36VDC	5k-1M	110	CE
RBCAND21-580	5VDC	38mA	80mA	±36VDC	5k-1M	110	

SPECIFICATIONS

All specifications are based on 25°C, Humidity <75%, Nominal Input Voltage, and Rated Output Load unless otherwise noted. We reserve the right to change specifications based on technological advances.

SPECIFICATION	TEST CONDITIONS		Min	Typ	Max	Unit
INPUT SPECIFICATIONS						
Input Voltage	Symbol: VCC	RBCAND21-3100 Model RBCAND21-580 Model	3.15 4.75	3.3 5	3.45 5.25	VDC
Input Surge Voltage	1 sec. max	RBCAND21-3100 Model RBCAND21-580 Model	-0.7 -0.7		5 7	VDC
TXD Logic Level (High Level)	Symbol: V _{IH}	RBCAND21-3100 Model RBCAND21-580 Model	0.7VCC 0.7VCC		3.6 5.5	VDC
TXD Logic Level (Low Level)	Symbol: V _{IL}	RBCAND21-3100 Model RBCAND21-580 Model	0 0		0.8 0.8	VDC
RXD Logic Level (High Level)	Symbol: V _{OH}	RBCAND21-3100 Model RBCAND21-580 Model	VCC-0.4 VCC-0.4	3.1 4.8		VDC
RXD Logic Level (Low Level)	Symbol: V _{OL}	RBCAND21-3100 Model RBCAND21-580 Model		0.2 0.2	0.4 0.4	VDC
TXD Drive Current	Symbol: I _T		2			mA
RXD Output Current	Symbol: I _R				10	mA
Serial Interface	Standard CAN controller interface					
TRANSMISSION SPECIFICATIONS						
Data Delay	Symbol: t _T	TXD Transmit Delay		60	115	ns
	Symbol: t _R	RXD Receive Delay		70	135	
	Symbol: t _{PRO(TXD-RXD)}	Cycle Delay		130	250	
OUTPUT SPECIFICATIONS						
Dominant Level (Logic 0)	Symbol: V _{(OD)CANH}	CANH	2.75	3.5	4.5	VDC
	Symbol: V _{(OD)CANL}	CANL	0.5	1.5	2.25	
Recessive Level (Logic 1)	Symbol: V _{(OR)CANH}	CANH	2	2.5	3	VDC
	Symbol: V _{(OR)CANL}	CANL	2	2.5	3	
Differential Level	Symbol: V _{diff(d)}	Dominant Level (Logic 0)	1.5	2	3	VDC
	Symbol: V _{diff(r)}	Recessive Level (Logic 1)	-0.05	0	0.05	
Bus Pin Maximum Withstand Voltage	Symbol: V _X		-36		+36	VDC
Bus Transient Voltage	Symbol: V _{Trs} , Meets ISO7637-3 standard		-100		+100	VDC
Bus Pin Leakage Current	Symbol: (VCC=0V, V _{CANH/L} =5V)		-5		5	µA
Differential Load Resistance	Symbol: R _L		45	60	65	Ω
Differential Input Impedance	Symbol: R _{diff}		20		100	kΩ
CAN Bus Interface	Meets ISO/DIS 11898 Standard Twisted-pair output					

SPECIFICATIONS						
All specifications are based on 25°C, Humidity <75%, Nominal Input Voltage, and Rated Output Load unless otherwise noted. We reserve the right to change specifications based on technological advances.						
SPECIFICATION	TEST CONDITIONS		Min	Typ	Max	Unit
ENVIRONMENTAL SPECIFICATIONS						
Operating Temperature			-40		+105	°C
Transportation & Storage Temperature			-50		125	°C
Operating Humidity	Non-Condensing		10		90	%
Pin Welding Resistance Temperature	Welding spot is 1.5mm away from the casing, 10 seconds				300	°C
Cooling Method			Free Air Convection			
GENERAL SPECIFICATIONS						
Isolation Voltage	Test for 1 minute, leakage current <1mA			3.0		kVDC
Insulation Resistance	Isolation Voltage 500VDC, Input-Output			1000		MΩ
PHYSICAL SPECIFICATIONS						
Weight			0.067oz (1.90g) Typ.			
Dimensions (L x W x H)	DIP8		0.72in x 0.58in x 0.28in (18.20mm x 14.80mm x 7.10mm)			
SAFETY CHARACTERISTICS						
Safety Standard & Certification			EN60950			
Safety Class					Class III	
EMI	CE		CISPR/EN55032		Class A ⁽¹⁾	
EMS	ESD	IEC/EN61000-4-2	Contact ±4kV (Bare component, Signal Port)			Perf. Criteria A
	RS	IEC/EN61000-4-3	10V/m (Bare Component)			Perf. Criteria A
	EFT	IEC/EN61000-4-4	±2kV (Bare Component, Signal Port)			Perf. Criteria B
	Surge	IEC/EN61000-4-5	±2kV (Bare Component, Signal Port)			Perf. Criteria A
	CS	IEC/EN61000-4-6	3Vr.m.s. (Bare Component)			Perf. Criteria A

NOTES

- See Fig. 3
- The performance indexes of the product models are as listed in the data sheet above, but some indexes of non-standard model products will exceed the above mentioned requirements. Contact factory for specific information.
- PCB surface may have micro-color difference-this is a normal phenomenon & does not affect use of product.
- Products shall be classified according to ISO14001 and related environmental laws and regulations & should be handled by qualifying units.
- Customization available.

Application Precautions:

- Please read instructions carefully before use; call factory if you have questions.
- Do not use product in hazardous area
- This product is powered by DC power supply. 220VAC power supply is prohibited.
- Do not dismount and assemble the product without permission to avoid failure or malfunction of equipment.
- Ex factory inspection and quality control have been strictly conducted for this product. If any abnormal operation or possibility of failure occurs in internal module, please contact factory for support.

**Due to advances in technology, specifications subject to change without notice.*

MECHANICAL DRAWINGS

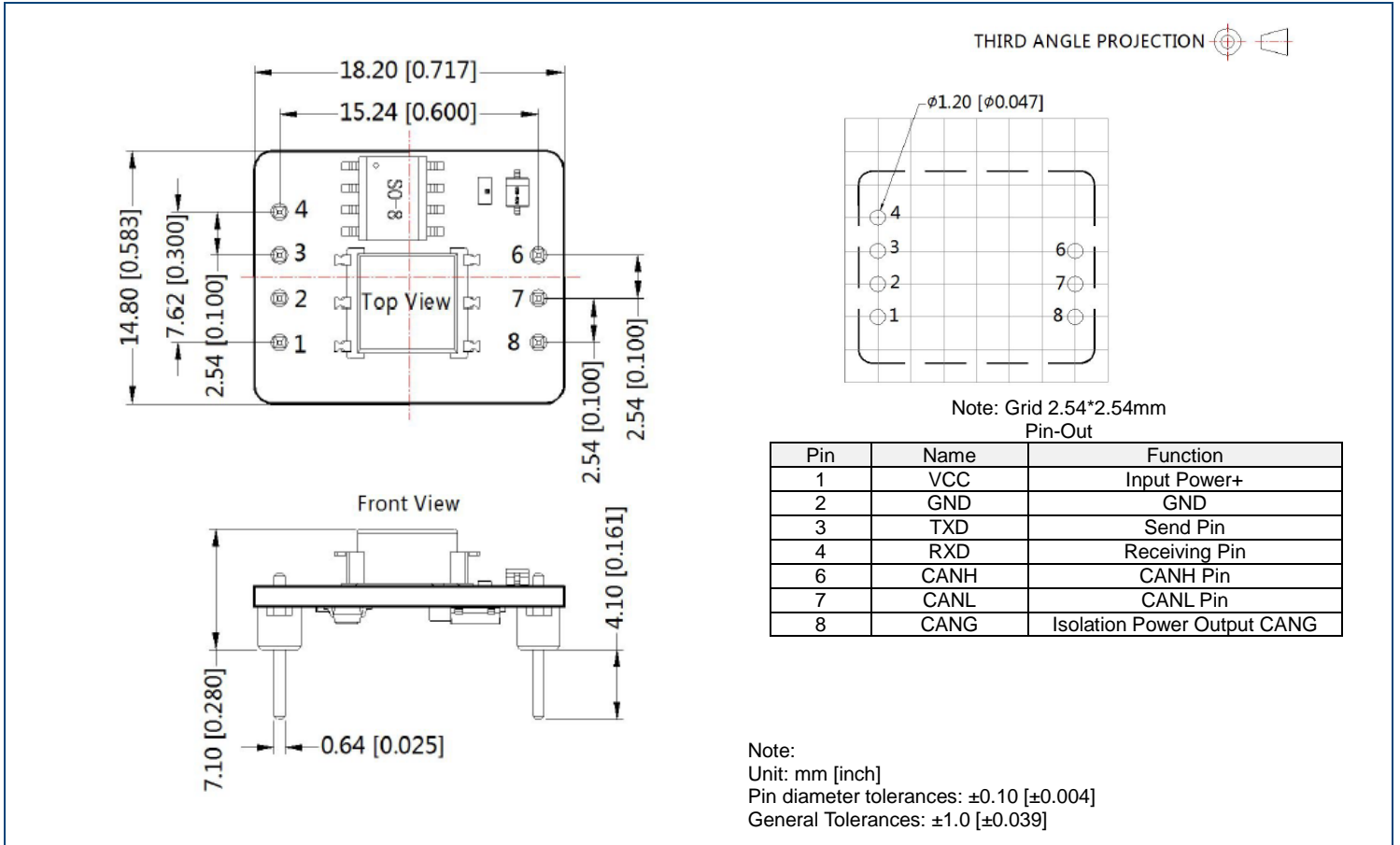

DESIGN REFERENCE

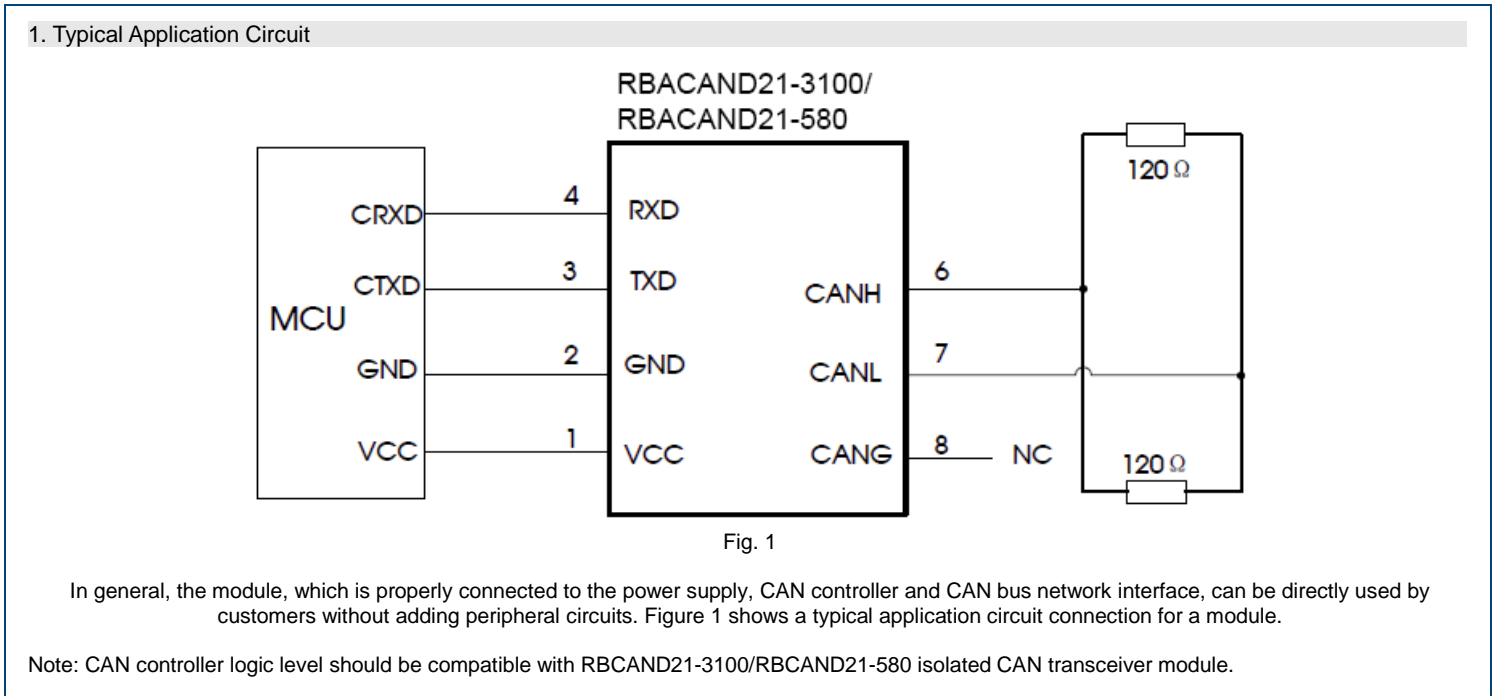

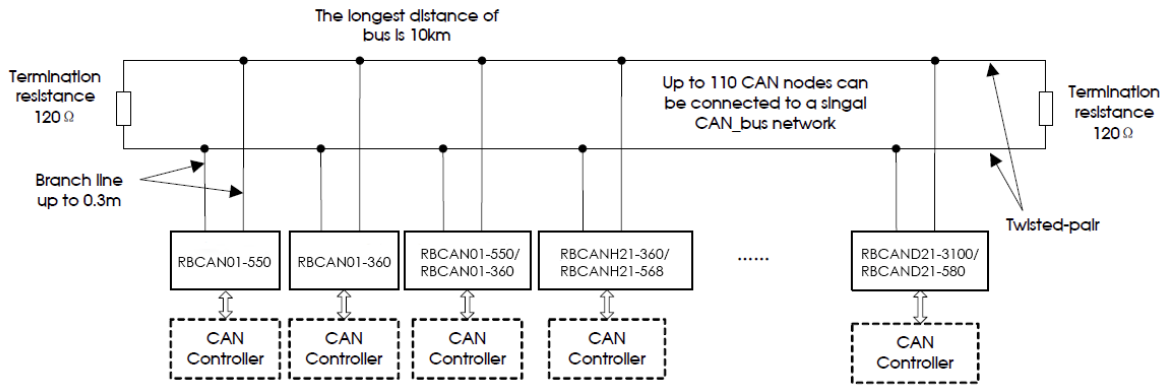

Fig. 2

As shown in Figure 2, a single CAN-bus network can connect up to 110 single-channel RBCAN isolated CAN transceiver modules. The universal type module can support a max. communication distance of 10km while the high-speed type module can support a max communication distance of 1km with baud rate beyond 40kbps. If looking to access more nodes or longer communication distance, it can be achieved by using CAN repeaters or other expansion equipment.

Notes: The communication distance of the bus is related to the communication speed and field application. It can be designed according to the actual application and reference standard. It is recommended that the communication cable is a twisted pair or shielded twisted pair and should stay away from the interference source. For long-distance communication, the terminal resistance value needs to be selected according to the communication distance and the cable impedance and the number of nodes.

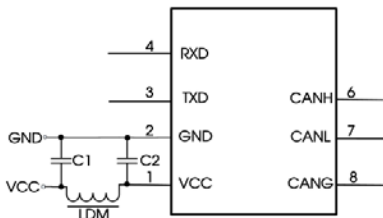

Fig. 3

Components	Parameter
C1 C2	1uF/16V
LDM	CD43-12uH

2. Recommended Port Protection Circuit

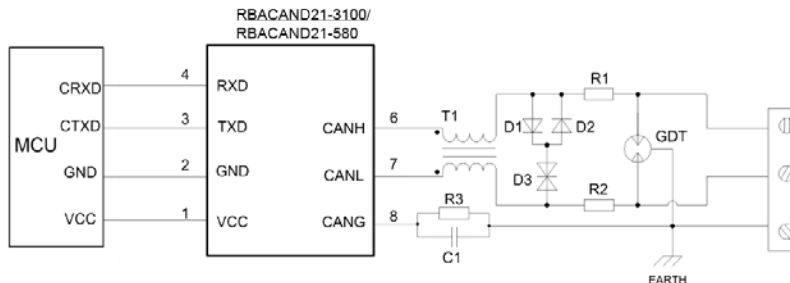

Fig. 4

Note: Twisted pair shield grounded reliably.

Parameter declaration:

Components	Recommended Parameters	Components	Recommended Parameters
R3	1MΩ	R1, R2	2.7Ω/2W
C1	102,2kV	D1, D2	1N4007
T1	ACM2520-301-2P	D3	SMBJ15CA
GDT	B3D090L		

When the module is used in harsh field environment, it is susceptible to the large energy of lightning strike. In this case, it is necessary to add protection circuit to the CAN signal port to protect the module from damage and ensure the reliability of bus communication. Figure 2 provides a recommended protection circuit design for the high-energy lightning surges, with a degree of protection related to the selected protection device. Parameter description lists a set of recommended circuit parameters, which can be adjusted according to the actual application situation. Also, when using the shielded cable, the reliable single-point grounding of the shield must be achieved.

Note: This recommended parameter is only the recommended value, which is subject to the actual application. Recommended R1, R2 use PTC, D1, D2 use fast recovery diodes.

COMPANY INFORMATION

Wall Industries, Inc. has created custom and modified units for over 50 years. Our in-house research and development engineers will provide a solution that exceeds your performance requirements on-time and on budget. Our ISO9001-2008 certification is just one example of our commitment to producing a high quality, well-documented product for our customers.

Our past projects demonstrate our commitment to you, our customer. Wall Industries, Inc. has a reputation for working closely with its customers to ensure each solution meets or exceeds form, fit and function requirements. We will continue to provide ongoing support for your project above and beyond the design and production phases. Give us a call today to discuss your future projects.

Contact **Wall Industries** for further information:

Phone: ☎ (603)778-2300
Toll Free: ☎ (888)597-9255
Fax: ☎ (603)778-9797
E-mail: sales@wallindustries.com
Web: www.wallindustries.com
Address: 37 Industrial Drive
Exeter, NH 03833