

## Wall Industries, Inc.

---

### JF SERIES

---

**2:1 Wide Input Voltage Ranges  
DIP and SMT Type Packages  
Single Outputs, RoHS Compliant  
15W Open Frame DC/DC Power Converters**

---

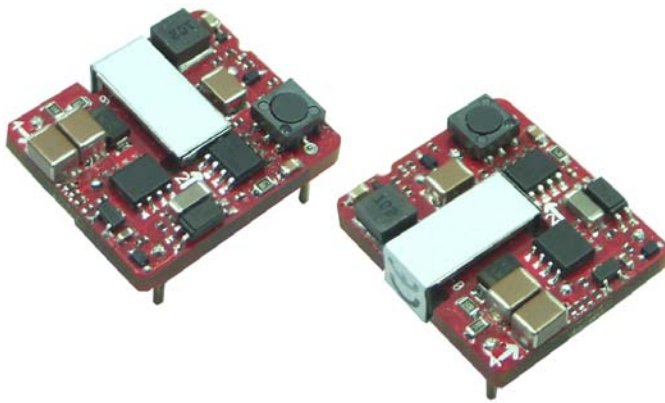

#### FEATURES

- 15 Watts Maximum Output Power
- Single Outputs
- Cost Efficient Open Frame Design
- Small Size and Low Profile: 1.10" x 0.94" x 0.34"
- High Efficiency up to 88%
- 2:1 Wide Input Voltage Ranges: 18-36VDC and 36-75VDC
- Fixed Switching Frequency
- Input to Output Isolation: 2250VDC
- No Minimum Load Requirement
- Output Voltage Adjustability
- Industry Standard Pin-out
- Negative or Positive Remote ON/OFF Control
- Short Circuit, Over Current, Over Voltage, and Input Under Voltage Protection
- SMT Package Qualified for Lead-free Reflow Solder Process According to IPC J-STD-020D
- CE Mark Meets 2006/95/EC, 93/68/EEC, and 2004/108/EC
- Compliant to RoHS EU Directive 2002/95/EC
- UL60950-1, EN60950-1, and IEC60950-1 Licensed
- Surface Mount and Through Hole Types Available

#### APPLICATIONS

- Wireless Networks
- Telecom / Datacom
- Industry Control Systems
- Measurement Equipment
- Semiconductor Equipment

#### OPTIONS

- SMT Type
- Without Trim Pin
- Without ON/OFF Pin
- Negative Logic Remote ON/OFF

---

#### DESCRIPTION

The JF series of DC/DC power converters provides 15 Watts of output power in a low profile industry standard package and footprint. These converters have single outputs and operate over 2:1 input voltage ranges of 18-36VDC and 36-75VDC. These units are also protected against short circuit, over current, over voltage, and input under voltage conditions. Some features include high efficiency up to 88%, adjustable output voltage, and positive or negative remote ON/OFF control. These converters are RoHS compliant and have UL60950-1, EN60950-1, and IEC60950-1 safety approvals. Both surface mount ("S" suffix) and DIP (standard) packages are available.

SPECIFICATIONS: JF Series						
All specifications are based on 25°C, Nominal Input Voltage, and Maximum Output Current unless otherwise noted. We reserve the right to change specifications based on technological advances.						
SPECIFICATION	TEST CONDITIONS	Min	Typ	Max	Unit	
<b>INPUT SPECIFICATIONS</b>						
Input Voltage Range	24VDC nominal input models	18	24	36	VDC	
	48VDC nominal input models	36	48	75		
Input Current		See Table				
Input Surge Voltage (100ms)	24VDC nominal input models			50	VDC	
	48VDC nominal input models			100		
UVLO Turn-On Threshold	24VDC nominal input models		18		VDC	
	48VDC nominal input models		36			
UVLO Turn-Off Threshold	24VDC nominal input models		14.5		VDC	
	48VDC nominal input models		30.5			
Input Reflected Ripple Current	12μH source impedance (π filter with 220μF & 33μF capacitors)		30		mAp-p	
<b>OUTPUT SPECIFICATIONS</b>						
Output Voltage		See Table				
Voltage Accuracy	Full load an nominal Vin	-1		+1	%	
Output Voltage Overshoot			3		%	
Line Regulation	Low line to high line at full load	-0.2		+0.2	%	
Load Regulation	No load to full load	-0.2		+0.2	%	
Voltage Adjustability (See Note 6)		-10		+10	%	
Output Power				15	W	
Output Current		See Table				
Ripple & Noise (20Hz BW)	Measured with a 1μF M/C and a 10μF T/C	See Table				
Transient Response Recovery Time	ΔIo/Δt=0.1A/μs (25% load step change)		300		μs	
Start-Up Time	Nominal input and constant resistive load	Power Up		30	ms	
		Remote ON/OFF		30		
Minimum Load		0			A	
Temperature Coefficient		-0.02		+0.02	%/°C	
<b>PROTECTION</b>						
Over Voltage Protection	Voltage clamped	3.3VDC Output Model	3.7		5.4	VDC
		5VDC Output Model	5.6		7.0	
		12VDC Output Model	13.5		19.6	
		15VDC Output Model	16.8		20.5	
Over Load Protection				150	%	
Short Circuit Protection		Hiccup, automatic recovery				
<b>GENERAL SPECIFICATIONS</b>						
Efficiency	Nominal input and full load	See Table				
Switching Frequency	3.3VDC & 5VDC Output Models	243	270	297	KHz	
	12VDC & 15VDC Output Models	423	470	517		
Isolation Voltage (Input to Output)	For 1 minute	2250			VDC	
Isolation Resistance		10			MΩ	
Isolation Capacitance				1000	pF	
<b>REMOTE ON/OFF (See Note 7)</b>						
Positive Logic (standard)	DC/DC ON		Open or 3V < Vr < 15V			
	DC/DC OFF		Short or 0V < Vr < 1.2V			
Negative Logic (optional)	DC/DC ON		Short or 0V < Vr < 1.2V			
	DC/DC OFF		Open or 3V < Vr < 15V			
Input Current of Remote Control Pin	Nominal Input	-0.5		1	mA	
Remote Off Input Current	Nominal Input		20		mA	
<b>ENVIRONMENTAL SPECIFICATIONS</b>						
Operating Ambient Temperature (See Note 8)	With derating	-40		+85	°C	
Storage Temperature		-55		+125	°C	
Relative Humidity		5		95	% RH	
Thermal Shock		MIL-STD-810F				
Vibration		MIL-STD-810F				
Lead-Free Reflow Solder Process		IPC J-STD-020D				
Moisture Sensitivity Level (MSL)		IPC J-STD-033B Level 2a				
MTBF (See Note 1)	BELLCORE TR-NWT-000332	2,200,000 hours				
	MIL-HDBK-217F	1,314,000 hours				
<b>PHYSICAL SPECIFICATIONS</b>						
Weight		0.36oz (10.5g)				
Dimensions (L x W x H)		1.10 x 0.94 x 0.34 inches (27.9 x 23.9 x 8.5 mm)				
<b>SAFETY &amp; EMC CHARACTERISTICS</b>						
Safety Approvals		IEC60950-1, UL60950-1, EN60950-1				
EMI (See Note 9)	EN55022	Class A				
Radiated Immunity	EN61000-4-3	10 V/m	Perf. Criteria A			
Fast Transient (See Note 10)	EN61000-4-4	±2KV	Perf. Criteria B			
Surge (See Note 10)	EN61000-4-5	±1KV	Perf. Criteria A			
Conducted Immunity	EN61000-4-6	10 Vrms	Perf. Criteria A			

**MODEL SELECTION TABLE**

Model Number	Input Range	Output Voltage	Output Current		Output <sup>(4)</sup> Ripple & Noise	Input Current		Output Power	Efficiency <sup>(4)</sup>	Capacitor <sup>(5)</sup> Load max
			Min. load	Full load		No load <sup>(3)</sup>	Full load <sup>(2)</sup>			
JF24S3.3-3500	24 VDC (18 - 36 VDC)	3.3 VDC	0mA	3500mA	75mVp-p	20mA	587mA	11.5W	86%	10000µF
JF24S5-3000		5 VDC	0mA	3000mA	75mVp-p	20mA	753mA	15W	87%	6000µF
JF24S12-1250		12 VDC	0mA	1250mA	100mVp-p	15mA	753mA	15W	87%	1000µF
JF24S15-1000		15 VDC	0mA	1000mA	100mVp-p	15mA	744mA	15W	88%	660µF
JF48S3.3-3500	48 VDC (36 - 75 VDC)	3.3 VDC	0mA	3500mA	75mVp-p	15mA	297mA	11.5W	85%	10000µF
JF48S5-3000		5 VDC	0mA	3000mA	75mVp-p	15mA	377mA	15W	87%	6000µF
JF48S12-1250		12 VDC	0mA	1250mA	100mVp-p	10mA	377mA	15W	87%	1000µF
JF48S15-1000		15 VDC	0mA	1000mA	100mVp-p	10mA	372mA	15W	88%	660µF

\*\*\*\*See Product Options table on page 5\*\*\*\*

**NOTES**

- BELLCORE TR-NWT-000332. Case 1: 50% Stress, Temperature at 40°C. MIL-HDBK-217F Notice2 @ Ta=25°C, Full load (Ground, benign, controlled environment).
- Maximum value at nominal input voltage and full load.
- Typical value at nominal input voltage and no load.
- Typical value at nominal input voltage and full load.
- Test by minimum input and constant resistive load.
- Trimming allows the user to increase or decrease the output voltage set point of the module. This is accomplished by connecting an external resistor between the TRIM pin and either the +OUTPUT pin or the -OUTPUT pin.
- The CTRL pin voltage is referenced to -INPUT. (See the “Product Options” table on page 5 for suffix options).
- The power module can operate in a variety of thermal environments; however, sufficient cooling should be provided to help ensure reliable operation.
- The JF Series meets EN55022 Class A and Class B only with external components connected to the input pins of the converter.
- An external filter capacitor is required if the module has to meet EN61000-4-4 and EN61000-4-5. The filter capacitor suggested is Nippon chemi-con KY Series, 220µF/100V, ESR 48mΩ.

**CAUTION:** These power modules are not internally fused. An input line fuse must always be used.

**OUTPUT ADJUSTABILITY**

Output voltage adjustment allows the user to increase or decrease the output voltage set point of a module. This is accomplished by connecting an external resistor between the TRIM pin and either the +OUTPUT or -OUTPUT pins. With an external resistor between the TRIM and -OUTPUT pin, the output voltage set point increases. With an external resistor between the TRIM and +OUTPUT pin, the output voltage set point decreases. The external TRIM resistor needs to be at least 1/16W.

**Trim Up Equation**

$$R_U = \left[ \frac{G \times L}{(V_{O,up} - L - K)} - H \right] \Omega$$

**Trim Down Equation**

$$R_D = \left[ \frac{(V_{O,down} - L) \times G}{(V_O - V_{O,down})} - H \right] \Omega$$

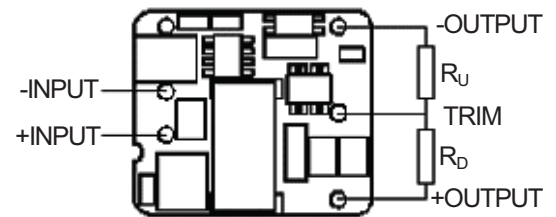

Model	G	H	K	L
JFXXS3.3-3500	5110	2050	0.8	2.5
JFXXS5-3000	5110	2050	2.5	2.5
JFXXS12-1250	10000	5110	9.5	2.5
JFXXS15-1000	10000	5110	12.5	2.5

## CHARACTERISTIC CURVES

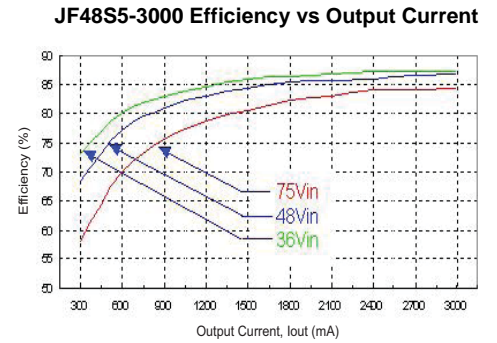
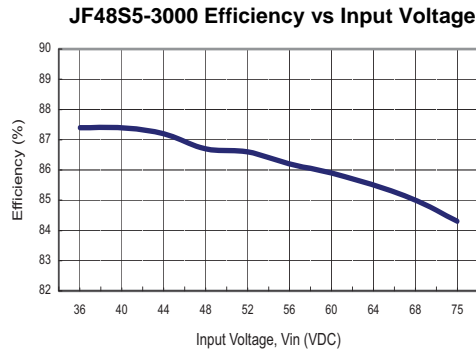
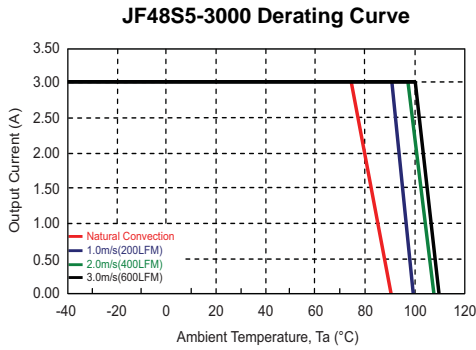

## RECOMMENDED EMI FILTERS

### Recommended Filter for EN55022 Class A Compliance

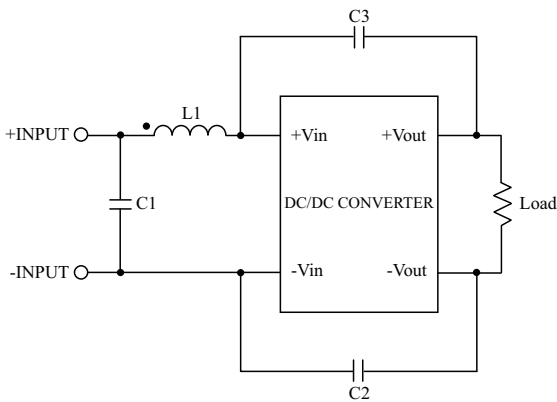

The components used in the figure above are as follows:

MODEL	C1	C2, C3	L1
JF24Sxx-xxxx	6.8μF/50V 1812 MLCC	470pF/3KV 1808 MLCC	10μF SMT Inductor PMT-047
JF48Sxx-xxxx	2.2μF/100V 1812 MLCC	470pF/3KV 1808 MLCC	18μF SMT Inductor PMT-046

### Recommended Filter for EN55022 Class B Compliance

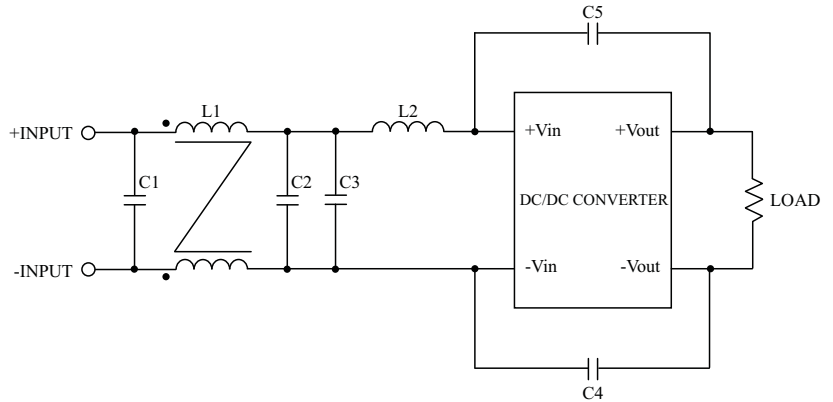

The components used in the figure above are as follows:

MODEL	C1 & C2	C3	C4 & C5	L1	L2
JF24Sxx-xxxx	6.8μF/50V 1812 MLCC	6.8μF/50V 1812 MLCC	470pF/3KV 1808 MLCC	145μH Common Choke PMT-051	10μF SMT Inductor PMT-047
JF48Sxx-xxxx	2.2μF/100V 1812 MLCC	2.2μF/100V 1812 MLCC	470pF/3KV 1808 MLCC	145μH Common Choke PMT-051	18μF SMT Inductor PMT-046

### Recommended EN55022 Class A Filter Circuit Layout

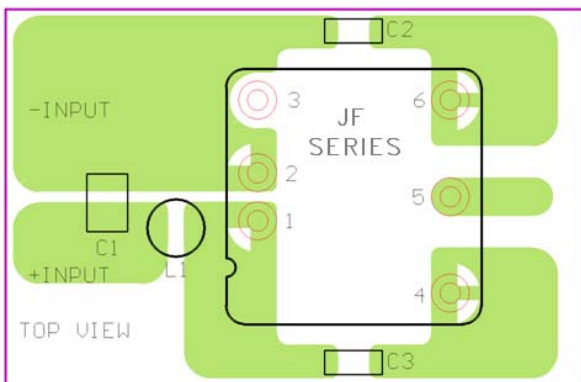

### Recommended EN55022 Class B Filter Circuit Layout

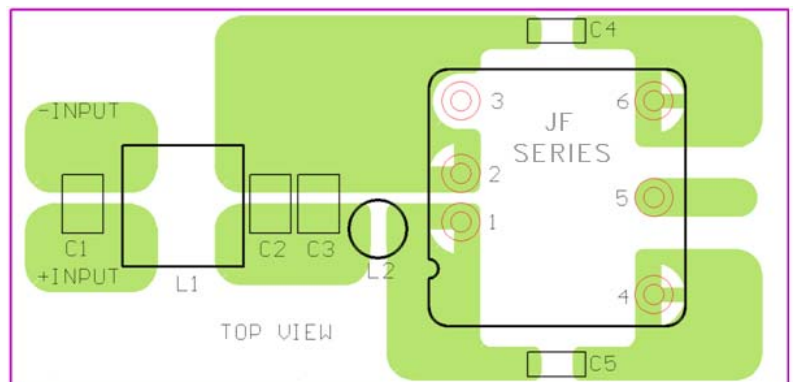

**MECHANICAL DRAWING**

**DIP TYPE (Standard)**

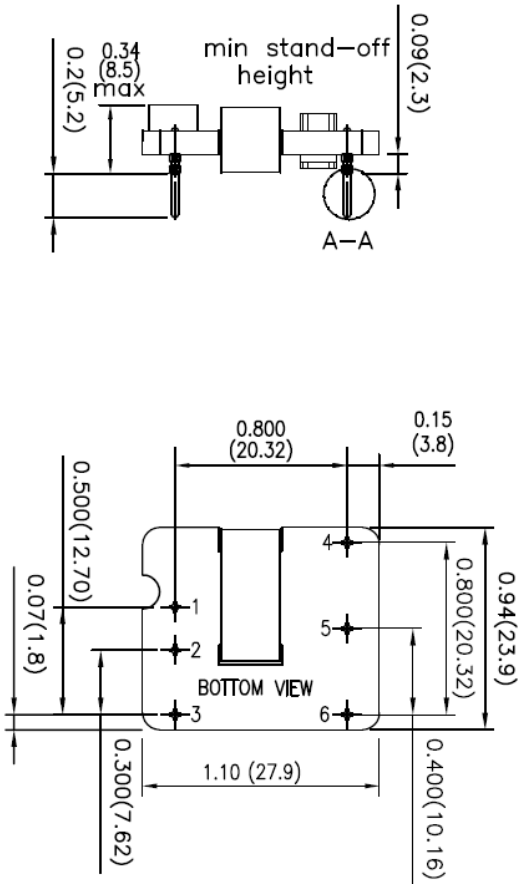

1. Unit: inches (mm)
2. Tolerance: X.XX±0.02 (X.X±0.5)  
X.XXX±0.01 (X.XX±0.25)
3. Pin pitch tolerance: ±0.01 (±0.25)
4. Pin dimension tolerance: ±0.004 (±0.1)

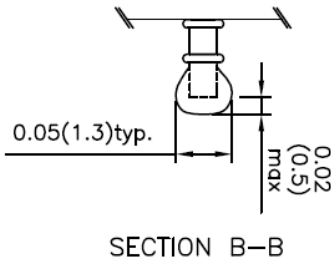
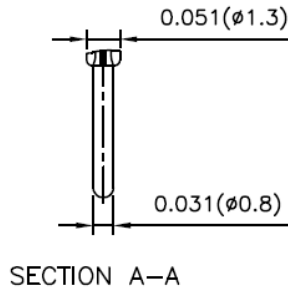

**SMT TYPE (Suffix "S")**

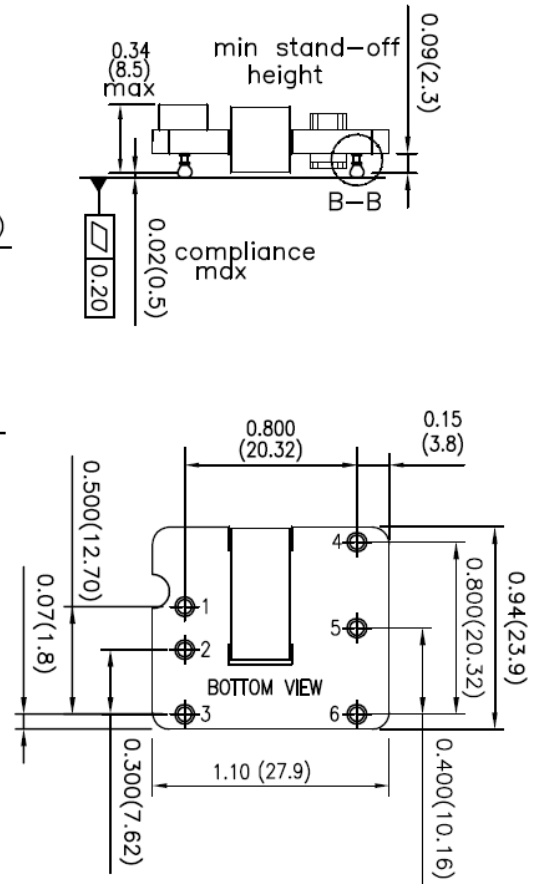

PAD LAYOUT 6 PADS ø2.8mm

PIN CONNECTIONS	
PIN	JF SERIES
1	+INPUT
2	-INPUT
3	CTRL
4	+OUTPUT
5	TRIM
6	-OUTPUT

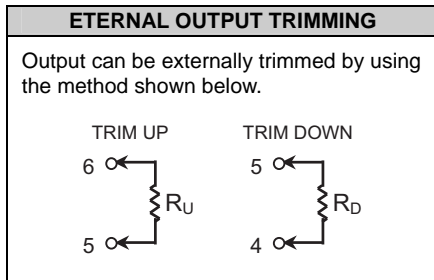

PRODUCT OPTIONS	
Option	Suffix
Positive Remote ON/OFF with DIP (standard)	No Suffix
Positive remote ON/OFF with SMT	S
Negative Remote ON/OFF with DIP	R
Negative Remote ON/OFF with SMT	SR
DIP type without ON/OFF pin	D
SMT type without ON/OFF pin	SD
DIP type without ON/OFF & TRIM pin	G
SMT type without ON/OFF & TRIM pin	SG
DIP type, negative remote ON/OFF, without TRIM pin	F
SMT type, negative remote ON/OFF, without TRIM pin	SF
DIP type, positive remote ON/OFF, without TRIM pin	J
SMT type, positive remote ON/OFF, without TRIM pin	SJ

**ORDERING INFORMATION**

Part Number Example:

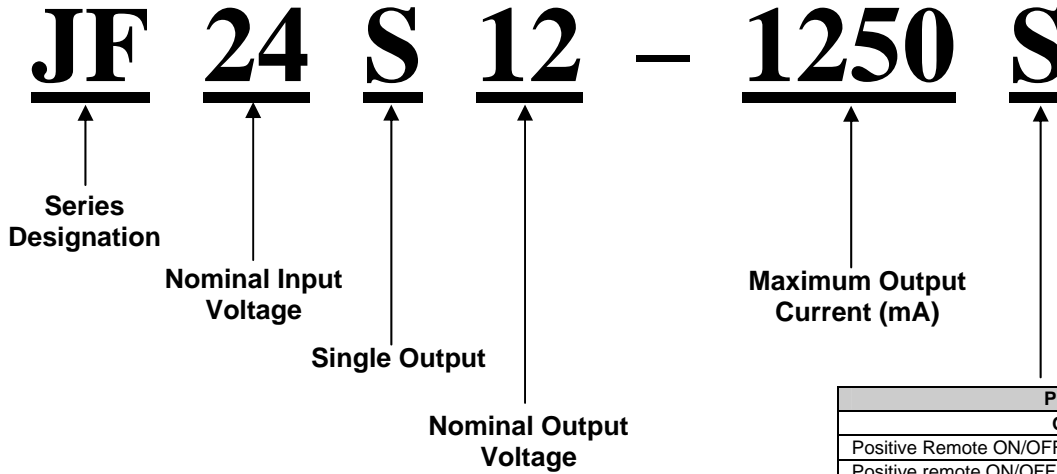

PRODUCT OPTIONS	
Option	Suffix
Positive Remote ON/OFF with DIP (standard)	No Suffix
Positive remote ON/OFF with SMT	S
Negative Remote ON/OFF with DIP	R
Negative Remote ON/OFF with SMT	SR
DIP type without ON/OFF pin	D
SMT type without ON/OFF pin	SD
DIP type without ON/OFF & TRIM pin	G
SMT type without ON/OFF & TRIM pin	SG
DIP type, negative remote ON/OFF, without TRIM pin	F
SMT type, negative remote ON/OFF, without TRIM pin	SF
DIP type, positive remote ON/OFF, without TRIM pin	J
SMT type, positive remote ON/OFF, without TRIM pin	SJ

**COMPANY INFORMATION**

Wall Industries, Inc. has created custom and modified units for over 50 years. Our in-house research and development engineers will provide a solution that exceeds your performance requirements on-time and on budget. Our ISO9001-2008 certification is just one example of our commitment to producing a high quality, well-documented product for our customers.

Our past projects demonstrate our commitment to you, our customer. Wall Industries, Inc. has a reputation for working closely with its customers to ensure each solution meets or exceeds form, fit and function requirements. We will continue to provide ongoing support for your project above and beyond the design and production phases. Give us a call today to discuss your future projects.

Contact **Wall Industries** for further information:

Phone:                    ☎ (603)778-2300  
Toll Free:                ☎ (888)587-9255  
Fax:                        ☎ (603)778-9797  
E-mail:                    [sales@wallindustries.com](mailto:sales@wallindustries.com)  
Web:                        [www.wallindustries.com](http://www.wallindustries.com)  
Address:                  5 Watson Brook Rd.  
                                      Exeter, NH 03833