

SELF-LEADED SMD INDUCTOR DR339-2 SERIES

Features

- Low Profile Surface Mount Design
- Flat Top for Pick and Place
- Inductance Range from 0.47 μ H to 330 μ H
- Operating Temp. -40°C to +85°C
- Tinned Leads with Leaded Solder is Available (note 9)



ELECTRICAL SPECIFICATIONS AT 25°C

Part No.	Inductance (μ H)	DCR (Ω) Max.	RATED CURRENT (A) Max.	I_{sat} (A) Max.
DR339-2-471	0.47 +40%/-20%	0.005	10.6	11.4
DR339-2-102	1.0 +40%/-20%	0.007	9.3	9.9
DR339-2-152	1.5 +40%/-20%	0.009	8.3	7.9
DR339-2-222	2.2 \pm 20%	0.011	7.2	6.1
DR339-2-332	3.3 \pm 20%	0.013	6.5	5.1
DR339-2-472	4.7 \pm 20%	0.017	5.5	4.2
DR339-2-682	6.8 \pm 20%	0.021	5.0	3.6
DR339-2-103	10.0 \pm 20%	0.028	4.3	3.3
DR339-2-153	15.0 \pm 20%	0.041	3.5	2.4
DR339-2-223	22.0 \pm 20%	0.062	2.8	2.0
DR339-2-333	33.0 \pm 20%	0.092	2.1	1.7
DR339-2-473	47.0 \pm 20%	0.139	1.7	1.4
DR339-2-683	68.0 \pm 20%	0.179	1.5	1.2
DR339-2-104	100.0 \pm 20%	0.271	1.4	0.95
DR339-2-154	150.0 \pm 20%	0.424	1.1	0.78
DR339-2-224	220.0 \pm 20%	0.636	0.93	0.62
DR339-2-334	330.0 \pm 20%	0.977	0.76	0.51

MECHANICAL OUTLINES

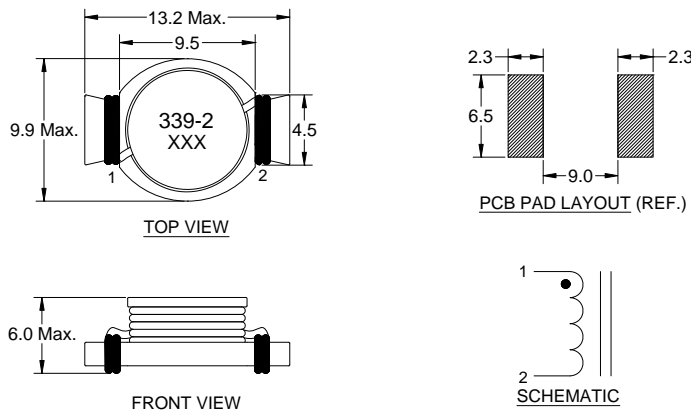

Notes:

1. All dimensions are shown in millimeter "mm"
2. General tolerance \pm 0.2mm, unless other specified
3. Inductance Test: 100kHz, 0.25Vrms
4. I_{rms} for an approximate 45°C temperature rise
5. I_{SAT} for an approximate 20% drop maximum of the nominal value
6. Tape and reel quantity, 500 pcs/reel
7. Terminal finish is compliant to RoHS requirements
8. Solder in accordance with J-STD-002 Rev. D
9. Non-RoHS series parts 42-339-2-XXX are finished with leaded solder Sn60Pb40 or equivalent