

ABRIDGED DATA SHEET

EVALUATION KIT AVAILABLE

MAX32560

DeepCover Secure Arm Cortex-M3 Flash Microcontroller

General Description

DeepCover® embedded security solutions cloak sensitive data under multiple layers of advanced physical security to provide the most secure key storage possible.

The DeepCover Secure microcontroller (MAX32560) provides an interoperable, secure, and cost-effective solution to build new generations of trusted devices such as mobile chip and pin pads. The MAX32560 is based on an Arm® Cortex®-M3 processor with 1MB of embedded flash, 384KB of system RAM, 8KB of battery-backed AES self-encrypted NVSRAM. In addition to a high-performance QSPI® interface for secure code execution and data storage, it includes all the essential functions of mobile POS terminal including an RF contactless controller with the embedded transceiver, a cryptographic engine, a true random number generator, battery-backed RTC, environmental and tamper detection circuitry, a magnetic stripe reader, a smart card controller with embedded transceiver to directly support 1.8V, 3.3V, and 5V cards, and an integrated secure keypad controller. It also provides a seamless interface to monochrome graphic displays and includes a vast array of peripherals, SPIs, UARTs, DMA, ADC, and DAC that add flexibility to control and differentiate the system design.

Applications

- PCI Mobile Payment Terminals (mPOS)
- ATM Keyboards
- EMV Card Reader
- Contact/Contactless Pin Pads

Functional Diagram

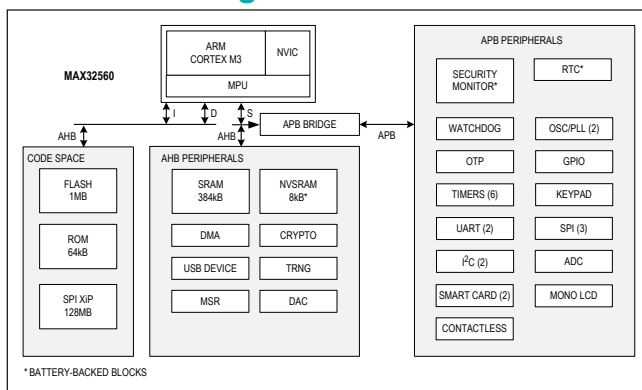

*5V smart card support requires external 5.0V supply.

DeepCover is a registered trademark of Maxim Integrated Products, Inc.

Arm and Cortex are registered trademarks of Arm Limited (or its subsidiaries) in the US and/or elsewhere.

QSPI is a trademark of Motorola, Inc.

Benefits and Features

- Arm Cortex M3 Processor Core Allows for Easy Integration into Applications
 - 108MHz Core Operating Frequency Through PLL
 - 1MB Dual-Bank Flash Memory with Cache
 - 384KB System SRAM
 - 8KB AES Self-Encrypted NVSRAM
- Security Features Facilitate System-Level Protection
 - ISO 14443 type A/B EMV Compliant Contactless Reader with Internal Transceiver
 - Secure Boot Loader with Public Key Authentication
 - AES, DES and SHA Hardware Accelerators
 - Modulo Arithmetic Hardware Accelerator (MAA) Supporting RSA, DSA, and ECDSA
 - 10-Line Secure Keypad Controller
 - Hardware True Random-Number Generator
 - Die Shield with Dynamic Fault Detection
 - 6 External Tamper Sensors with Independent Random Dynamic Patterns
 - 256-Bit Flip-Flop-Based Battery-Backup AES Key Storage
 - Temperature and Voltage Tamper Monitor
 - Real-Time Clock
- Integrated Peripherals Reduce External Component Count
 - Triple-Track Magnetic Stripe Head Interface
 - Two ISO 7816 Smart Card Interface with Integrated Transceiver (1.8V, 3V, and 5V)
 - USB 2.0 Device with Internal Transceiver and Dedicated PLL
 - 3 SPI Ports, 2 UART Ports, and 2 I²C Controller
 - 6 Timers, 4 with PWM Capability
 - Up to 68 General-Purpose I/O Pins
 - 2-Channel, 10-Bit ADC and 1-Channel, 8-Bit DAC
 - Monochrome LCD Controller
 - 4-Channel DMA Controller
 - 1 SPI Execute in Place (XiP) Master
- Power Management Optimizes Battery Life and Reduces Active Power Consumption
 - Single 3.3V Supply Operation*
 - Integrated Battery-Backup Switch
 - Clock Gating Function
 - Low-Current Battery-Backup Operation

ABRIDGED DATA SHEET

MAX32560

DeepCover Secure Arm Cortex-M3
Flash Microcontroller

Ordering Information

PART	PIN-PACKAGE	ICE
MAX32560-LNS+	144 CTBGA (10mm x 10mm, 0.8 mm pitch)	No
MAX32560-LNJ+	144 CTBGA (10mm x 10mm, 0.8 mm pitch)	Yes
MAX32560-LBS+	144 CTBGA (10mm x 10mm, 0.8 mm pitch)	No
MAX32560-LBJ+*	144 CTBGA (10mm x 10mm, 0.8 mm pitch)	Yes

+Denotes a lead(Pb)-free/RoHS-compliant package.

*Future product—contact factory for availability.

Package Information

For the latest package outline information and land patterns (footprints), go to www.maximintegrated.com/packages. Note that a "+", "#", or "-" in the package code indicates RoHS status only. Package drawings may show a different suffix character, but the drawing pertains to the package regardless of RoHS status.

PACKAGE TYPE	PACKAGE CODE	OUTLINE NO.	LAND PATTERN NO.
144 CTBGA	X14400+6C	21-0492	90-0347