

Highly Integrated AC/DC Primary-Side Rapid Charge™ PWM Controller Supporting XM-Comm Technology

1 Description

The iW1790 is a high performance AC/DC power supply controller for rapid charge that uses main transformer communication (XM-Comm) technology to minimize external component count and simplify system design. The device operates in quasi-resonant mode to provide high efficiency and it also provides a number of key built-in protection features. The iW1790 can achieve tight multi-level constant voltage and multi-level constant current regulation without a traditional secondary feedback circuit. It also eliminates the need for loop compensation components while maintaining stability over all operating conditions.

The iW1790 is optimized to work with Dialog's iW660/2/3 secondary-side controllers for various rapid charge protocols, such as Samsung Adaptive Fast Charge (AFC) (iW660), Qualcomm® Quick Charge™ 2.0 and 3.0 (QC2.0 – iW660/2/3 and QC3.0 – iW662) technologies, Huawei Fast Charger Protocol (FCP) (iW663), etc... to achieve fast and smooth voltage transitions upon request by mobile devices (MD). When paired with the iW660/2/3, the iW1790 completely eliminates the optocoupler between primary and secondary side. Using Dialog's proprietary transformer communication technology, XM-Comm, the iW660/2/3 can communicate with the iW1790 to send output voltage requests, output current limits, output voltage undershoot and over voltage information without any additional external components. The iW1790 paired with the iW660/2/3 can provide fast dynamic load response in typical AC/DC rapid charge adapter designs.

In addition, the iW1790 uses source charging technology to charge up V_{CC} before startup, which eliminates the external active start-up (ASU) circuit and still can achieve < 20mW no-load power consumption at 5V/2A output setting.

Dialog's innovative proprietary technology ensures that power supplies designed with the iW660/2/3 and iW1790 can provide various output voltage configurations for AFC/QC2.0/QC3.0/FCP and other proprietary protocols, with various user-selected output current limit combinations.

Qualcomm® Quick Charge™ 2.0 and 3.0 are products of Qualcomm Technologies, Inc.

2 Features

- Integrated XM-Comm technology eliminates secondary-to-primary optocoupler
- Transformer communication for all the rapid charge information: output voltage request, output current limit, output voltage undershoot, and over-voltage protection
- Source charging V_{CC} technology eliminates the active start-up (ASU) and maintain ultra-low no-load power consumption (< 20mW) at 230V_{AC} with typical 5V/2A output setting
- High V_{CC} pin voltage rating eliminates external V_{CC} LDO
- Tight multi-level constant-voltage and multi-level constant-current regulation with primary-side feedback and control
- Fast dynamic load response (DLR)
- Proprietary optimized load adaptive maximum constant frequency PWM switching with quasi-resonant operation achieves best size, efficiency, and common mode noise
- Multi-mode PWM/PFM control improves efficiency at various load conditions
- User-configurable 4-level cable drop compensation independent of output voltage
- **EZ-EMI**® design enhances manufacturability
- Built-in single-point fault protections against output short-circuit including soft short and half short, output over-voltage, and output over-current
- **SmartDefender+**™ control technology addresses issues of soft shorts in cables and connectors by effectively reducing the average output power at fault conditions without latch
- Dual over-temperature protection with both internal OTP and external shutdown control
- No audible noise over entire operating range
- Supports rapid charge technologies, such as AFC, QC 2.0 and 3.0 technologies, FCP, etc.

Highly Integrated AC/DC Primary-Side Rapid Charge™ PWM Controller Supporting XM-Comm Technology

3 Applications

- Rapid-charging AC/DC adapters for smart phones, tablets and other portable devices (3.6V-12V, 1A-3A).

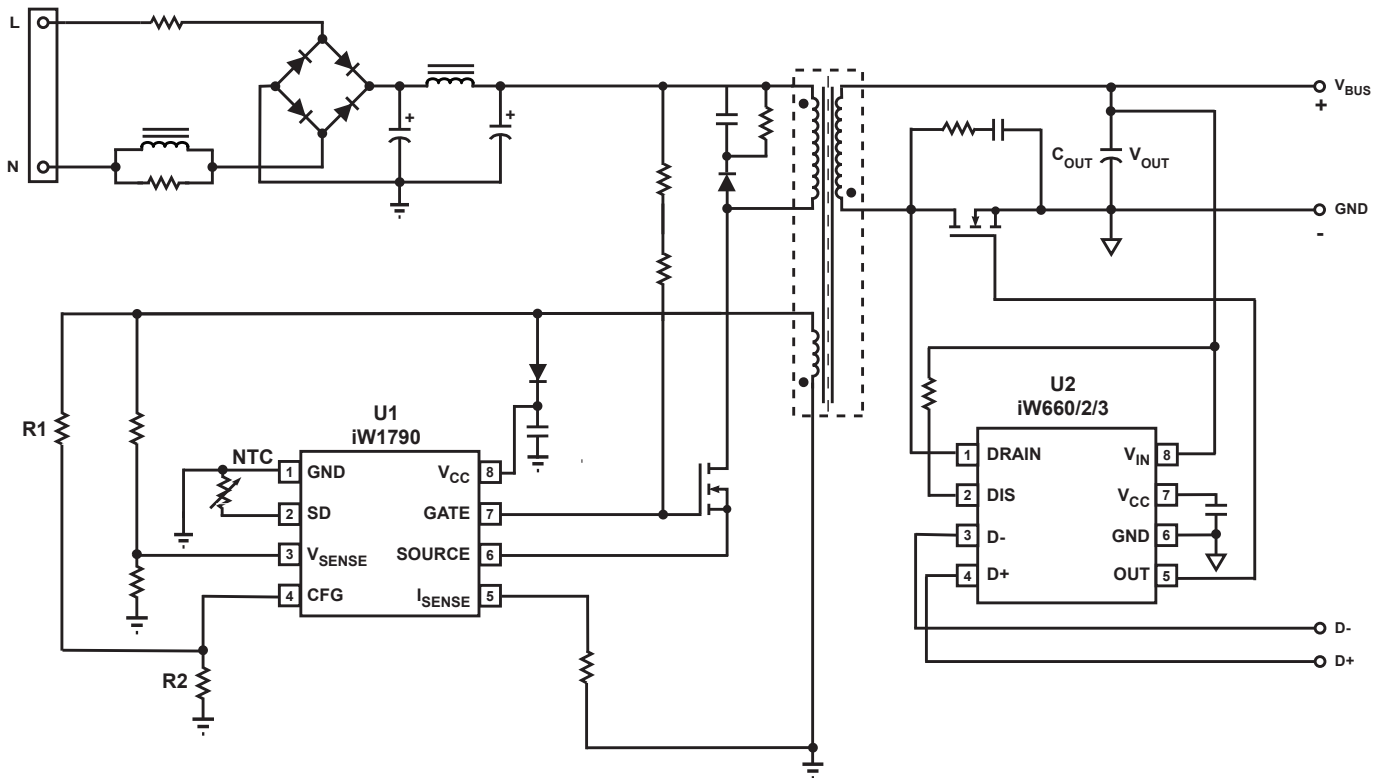

Figure 3.1 : iW1790 Typical Application Circuit for Multi-Level Output Voltage and Current (Using iW660 as Secondary-Side Controller for Rapid Charge Protocols. Achieving < 20mW No-Load Power Consumption in Typical 15W Design.)

Highly Integrated AC/DC Primary-Side Rapid Charge™ PWM Controller Supporting XM-Comm Technology

4 Pinout Description

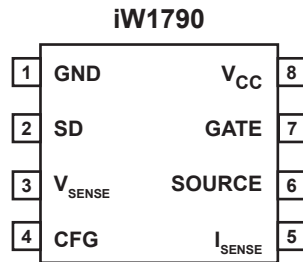

Figure 4.1 : 8-Lead SOIC-8 Package

Pin Number	Pin Name	Type	Pin Description
1	GND	Ground	Ground.
2	SD	Analog Input	SD function for external shutdown control. Can be configured for external over-temperature protection (OTP) by connecting an NTC resistor from this pin to Ground.
3	V_{SENSE}	Analog Input	Auxiliary voltage sense. Used for primary-side regulation and secondary-to-primary communication through main transformer.
4	CFG	Analog Input	Used for CDC configuration and auxiliary winding open protection.
5	I_{SENSE}	Analog Input	Primary-side current sense. Used for cycle-by-cycle peak-current control and limit in primary-side CV/CC regulation.
6	SOURCE	Power Input	Connect to the source of external power MOSFET. Inside the IC, it is connected to internal MOSFET and startup V_{CC} charge circuit.
7	GATE	Output	Gate drive for external MOSFET switch.
8	V_{CC}	Power Input	IC power supply.

Highly Integrated AC/DC Primary-Side Rapid Charge™ PWM Controller Supporting XM-Comm Technology

5 Absolute Maximum Ratings

Absolute maximum ratings are the parameter values or ranges which can cause permanent damage if exceeded. For maximum safe operating conditions, refer to the Electrical Characteristics section.

Parameter	Symbol	Value	Units
DC supply voltage range (pin 1, $I_{CC} = 20\text{mA max}$)	V_{CC}	-0.3 to 45.0	V
Continuous DC supply current at V_{CC} pin ($V_{CC} = 15\text{V}$)	I_{CC}	20	mA
V_{SENSE} input (pin 3, $I_{VSENSE} \leq 10\text{mA}$)		-0.7 to 10.0	V
CFG (pin 4)		-0.7 to 5.0	V
SD (pin 2)		-0.3 to 5.5	V
I_{SENSE} input (pin 5)		-0.7 to 5.0	V
SOURCE input (pin 6)		-0.7 to 25.0	V
GATE (pin 7)		-0.3 to 30	V
Maximum junction temperature	T_{JMAX}	150	°C
Operating junction temperature	T_{JOPT}	-40 to 150	°C
Storage temperature	T_{STG}	-65 to 150	°C
Thermal resistance junction-to-ambient	θ_{JA}	160	°C/W
ESD rating per JEDEC JESD22-A114		$\pm 2,000$	V
Latch-up test per JESD78D		± 100	mA

Note 1: Stresses beyond those listed under “Absolute maximum ratings” may cause permanent damage to the device. These are stress ratings only, so functional operation of the device at these or any other conditions beyond those indicated in the operational sections of the specification are not implied. Exposure to absolute maximum rating conditions for extended periods may affect device reliability.

Highly Integrated AC/DC Primary-Side Rapid Charge™ PWM Controller Supporting XM-Comm Technology

6 Physical Dimensions

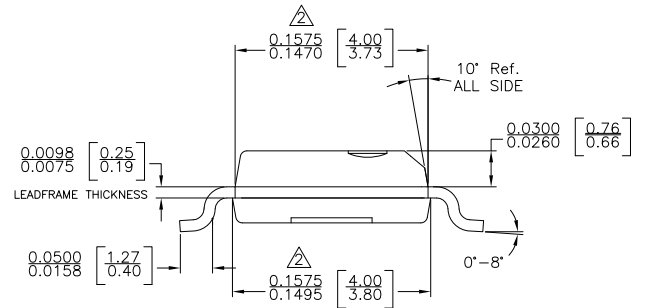
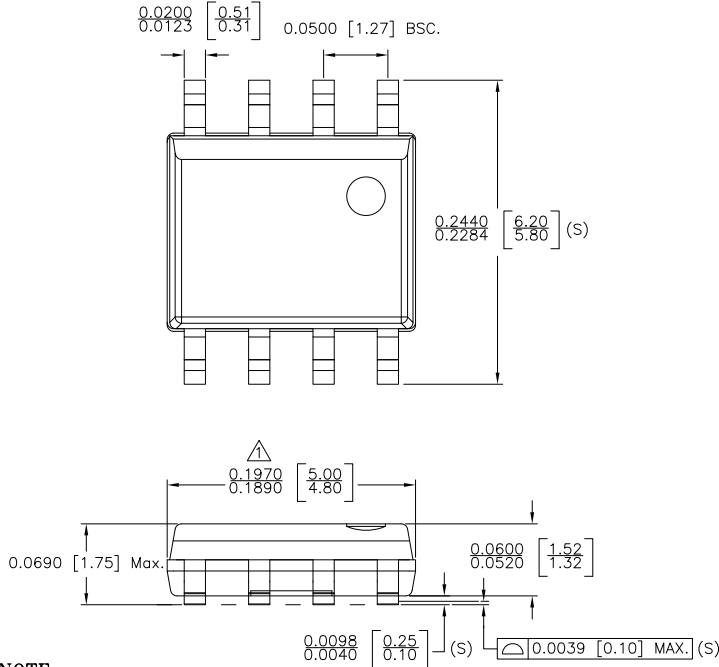

NOTE :

- △ DOES NOT INCLUDE MOLD FLASH, PROTRUSIONS OR GATE BURRS. MOLD FLASH, PROTRUSIONS AND GATE BURRS SHALL NOT EXCEED .006 INCH PER SIDE.
- △ DOES NOT INCLUDE INTER-LEAD FLASH OR PROTRUSIONS. INTER-LEAD FLASH AND PROTRUSIONS SHALL NOT EXCEED .010 INCH PER SIDE.
- 3. THIS PART IS COMPLIANT WITH JEDEC SPECIFICATION MS-012.
- 4. LEAD SPAN/STAND OFF HEIGHT/COPLANARITY ARE CONSIDERED AS SPECIAL CHARACTERISTIC(S)
- 5. CONTROLLING DIMENSIONS IN INCHES. [mm]

STATUS: RELEASED	SCALE: DO NOT SCALE
TERMINAL FINISH: 100% Sn or NiPdAu (PPF)	
TITLE: 8 SOIC PACKAGE OUTLINE	
REV: A	REVISION NOTE: NEW DRAWING
DATE: 02-MAR-2015	

Highly Integrated AC/DC Primary-Side Rapid Charge™ PWM Controller Supporting XM-Comm Technology

7 Ordering Information

Part Number	Status	Secondary-Side Controller	Options				Package	Description
			Protocol Supported	Default k_{CC} at Start-up	CC Shutdown Voltage	k_{CC} Comp. for $V_{BUS} > 6V$		
iW1790-00	Active	iW660-02	AFC	0.5	3.3V for $V_{BUS} = 5V$; 6.5V for $V_{BUS} = 9V$	No	SOIC-8	Tape & Reel ¹
iW1790-07	Active	iW662-01/ iW662-02	QC2.0/QC3.0	0.5	2.9V	Yes	SOIC-8	Tape & Reel ¹
iW1790-08	Active	iW662-00/ iW662-05	QC2.0/QC3.0	0.422	6.5V for $V_{BUS} = 9V$, 66% of V_{BUS} for other V_{BUS} ²	No	SOIC-8	Tape & Reel ¹
iW1790-08B	Recommended for New Designs	iW662-00/ iW662-05	QC2.0/QC3.0	0.422	6.5V for $V_{BUS} = 9V$, 66% of V_{BUS} for other V_{BUS} ²	No	SOIC-8	Tape & Reel ¹
iW1790-09	Active	iW662-01/ iW662-02	QC2.0/QC3.0	0.5	2.9V	No	SOIC-8	Tape & Reel ¹
iW1790-09B	Recommended for New Designs	iW662-01/ iW662-02	QC2.0/QC3.0	0.5	2.9V	No	SOIC-8	Tape & Reel ¹
iW1790-12	Active	iW663-02/ iW662-05	FCP/QC2.0/ QC3.0 Supports 5.25V/9V V_{BUS}	0.422	3.0V for $V_{BUS} < 9V$; 6.5V for $V_{BUS} = 9V$	No	SOIC-8	Tape & Reel ¹
iW1790-12B	Recommended for New Designs	iW663-02/ iW662-05	FCP/QC2.0/ QC3.0 Supports 5.25V/9V V_{BUS}	0.422	3.0V for $V_{BUS} < 9V$; 6.5V for $V_{BUS} = 9V$	No	SOIC-8	Tape & Reel ¹
iW1790-18	Active	iW662-18	QC2.0/QC3.0/ PE	0.422	3.0V for $V_{BUS} = 5V$; 6.5V for $V_{BUS} = 9V$	No	SOIC-8	Tape & Reel ¹
iW1790-18B	Recommended for New Designs	iW662-18	QC2.0/QC3.0/ PE	0.422	3.0V for $V_{BUS} = 5V$; 6.5V for $V_{BUS} = 9V$	No	SOIC-8	Tape & Reel ¹
iW1790-19	Active	iW662-03	QC2.0/QC3.0/ PE	0.5	2.9V	Yes	SOIC-8	Tape & Reel ¹
iW1790-19B	Recommended for New Designs	iW662-03	QC2.0/QC3.0/ PE	0.5	2.9V	Yes	SOIC-8	Tape & Reel ¹

Note 1: Tape & Reel packing quantity is 2,500/reel. Minimum packing quantity is 2,500.

Note 2: Clamped to 2.9V if 66% of $V_{BUS} \leq 2.9V$.

Note 3: Additional features and options may be available; contact Dialog Semiconductor.

Highly Integrated AC/DC Primary-Side Rapid Charge™ PWM Controller Supporting XM-Comm Technology

IMPORTANT NOTICE AND DISCLAIMER

RENESAS ELECTRONICS CORPORATION AND ITS SUBSIDIARIES (“RENESAS”) PROVIDES TECHNICAL SPECIFICATIONS AND RELIABILITY DATA (INCLUDING DATASHEETS), DESIGN RESOURCES (INCLUDING REFERENCE DESIGNS), APPLICATION OR OTHER DESIGN ADVICE, WEB TOOLS, SAFETY INFORMATION, AND OTHER RESOURCES “AS IS” AND WITH ALL FAULTS, AND DISCLAIMS ALL WARRANTIES, EXPRESS OR IMPLIED, INCLUDING, WITHOUT LIMITATION, ANY IMPLIED WARRANTIES OF MERCHANTABILITY, FITNESS FOR A PARTICULAR PURPOSE, OR NON-INFRINGEMENT OF THIRD PARTY INTELLECTUAL PROPERTY RIGHTS.

These resources are intended for developers skilled in the art designing with Renesas products. You are solely responsible for (1) selecting the appropriate products for your application, (2) designing, validating, and testing your application, and (3) ensuring your application meets applicable standards, and any other safety, security, or other requirements. These resources are subject to change without notice. Renesas grants you permission to use these resources only for development of an application that uses Renesas products. Other reproduction or use of these resources is strictly prohibited. No license is granted to any other Renesas intellectual property or to any third party intellectual property. Renesas disclaims responsibility for, and you will fully indemnify Renesas and its representatives against, any claims, damages, costs, losses, or liabilities arising out of your use of these resources. Renesas’ products are provided only subject to Renesas’ Terms and Conditions of Sale or other applicable terms agreed to in writing. No use of any Renesas resources expands or otherwise alters any applicable warranties or warranty disclaimers for these products.

© 2022 Renesas Electronics Corporation. All rights reserved.

RoHS Compliance

Dialog Semiconductor’s suppliers certify that its products are in compliance with the requirements of Directive 2011/65/EU of the European Parliament on the restriction of the use of certain hazardous substances in electrical and electronic equipment. RoHS certificates from our suppliers are available on request.

Corporate Headquarters

TOYOSU FORESIA, 3-2-24 Toyosu
Koto-ku, Tokyo 135-0061, Japan
www.renesas.com

Contact Information

For further information on a product, technology, the most up-to-date version of a document, or your nearest sales office, please visit:
www.renesas.com/contact/

Trademarks

Renesas and the Renesas logo are trademarks of Renesas Electronics Corporation. All trademarks and registered trademarks are the property of their respective owners.