

DRV10974 12-V, Three-Phase, Sensorless BLDC Motor Driver

1 Features

- Input Voltage Range: 4.4 V to 18 V
- Total Driver H + L $r_{DS(on)}$: 750 m Ω (Typical) at $T_A = 25^\circ\text{C}$
- Phase Drive Current: 1-A Continuous (1.5-A Peak)
- 180° Sinusoidal Commutation for Optimal Acoustic Performance
- Resistor-Configurable Lead Angle
- Resistor-Configurable Current Limit
- Soft Start With Resistor-Configurable Acceleration Profile
- Built-In Current Sense to Eliminate External Current-Sense Resistor
- Proprietary Sensorless Control Without Motor Center Tap
- Simple User Interface:
 - One-Pin Configuration for Start-Up
 - PWM Input Designates Magnitude of Voltage Applied to Motor
 - Open-Drain FG Output Provides Speed Feedback
 - Pin for Forward and Reverse Control
- Fully Protected:
 - Motor-Lock Detect and Restart
 - Overcurrent, Short-Circuit, Overtemperature, Undervoltage

2 Applications

- White Goods
- Fans, Blowers, and Pumps
- BLDC Motor Module

3 Description

The DRV10974 device is a three-phase sensorless motor driver with integrated power MOSFETs, which can provide continuous drive current up to 1 A (rms). The device is designed for cost-sensitive, low-noise, and low-external-component-count applications.

The DRV10974 device uses a proprietary sensorless control scheme to provide dependable commutation. The 180° sinusoidal commutation significantly reduces pure tone acoustics that are typical with 120° (trapezoidal) commutation. The DRV10974 spin-up is configured using a single external low-power resistor. The current limit can be set by an external low-power resistor.

The DRV10974 device provides for simple control of motor speed by applying a PWM input to control the magnitude of the drive voltage, or by driving the PWM pin with an analog voltage and monitoring the FG pin for speed feedback.

The DRV10974 device includes a number of features to improve efficiency. The resistor-configurable lead angle allows the user to optimize the driver efficiency by aligning the phase current and the phase BEMF. In addition, the use of low- $r_{DS(on)}$ MOSFETs helps to conserve power while the motor is being driven.

Device Information⁽¹⁾

PART NUMBER	PACKAGE	BODY SIZE (NOM)
DRV10974	HTSSOP (16)	5.00 mm x 4.40 mm
	WQFN (16)	4.00 mm x 4.00 mm

(1) For all available packages, see the orderable addendum at the end of the data sheet.

Application Schematic

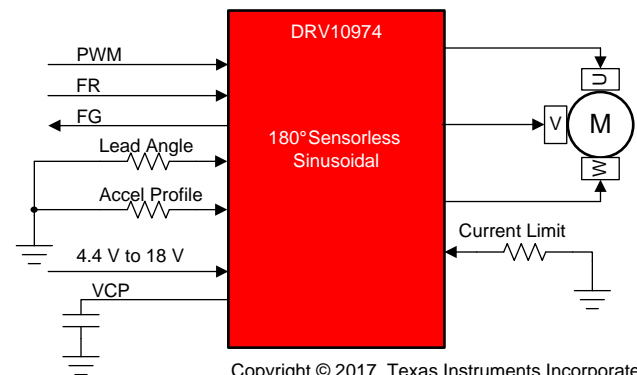

Table of Contents

1 Features	1	7.4 Device Functional Modes.....	19
2 Applications	1	8 Application and Implementation	24
3 Description	1	8.1 Application Information.....	24
4 Revision History	2	8.2 Typical Application	24
5 Pin Configuration and Functions	4	9 Power Supply Recommendations	26
6 Specifications	5	10 Layout	26
6.1 Absolute Maximum Ratings	5	10.1 Layout Guidelines	26
6.2 ESD Ratings.....	6	10.2 Layout Example	26
6.3 Recommended Operating Conditions.....	6	11 Device and Documentation Support	28
6.4 Thermal Information	6	11.1 Device Support	28
6.5 Electrical Characteristics.....	6	11.2 Receiving Notification of Documentation Updates	28
6.6 Typical Characteristics	10	11.3 Community Resources.....	28
7 Detailed Description	11	11.4 Trademarks	28
7.1 Overview	11	11.5 Electrostatic Discharge Caution.....	28
7.2 Functional Block Diagram	12	11.6 Glossary	28
7.3 Feature Description.....	12	12 Mechanical, Packaging, and Orderable Information	28

4 Revision History

Changes from Revision B (June 2018) to Revision C	Page
• Changed document status from MIXED STATUS to PRODUCTION DATA.....	1
• Deleted "Adv. info." designation from the WQFN entry in the <i>Device Information</i> table.....	1
• Deleted the "Advance informatoin" note from the WQFN pinout drawing.....	4
• Deleted the "Advance Information" note from the <i>Thermal Information</i> table	6
• Added description of Analog Mode Speed Control	14
• Added Kt High and Kt Low descriptions in abnormal Kt lock detect figure	17
• Added layout example for QFN package type.....	27

Changes from Revision A (April 2018) to Revision B	Page
• Added WQFN package to the <i>Device Information</i> table.....	1
• Added pinout drawing for the WQFN package.....	4
• Added a column to the <i>Pin Functions</i> table for the WQFN package, and added the TYPE column	5
• Added a column to the <i>Thermal Information</i> table for the VQFN package	6
• Changed $r_{DS(on)}$ vs. Temperature graph to include V_{CC} condition.....	10
• Changed Speed-Control Transfer Function figure to clearly show when the device enters and exits low power mode	14
• Updated Lock BEMF Abnormal text for clarity	16
• Changed <i>Detailed Design Procedure</i> to cover the high level tuning process of the RMP, ADV, and CS settings.....	25

Changes from Original (January 2018) to Revision A	Page
• Added or changed several bullets in the <i>Features</i> list	1
• Changed text in the third paragraph of the <i>Description</i> section	1
• Added parameter symbol (f_{PWM_OUT}) to the 25-kHz PWM signal.....	12
• Added parameter symbol (f_{PWM_OUT}) to the 25-kHz PWM signal.....	13
• Added parameter symbol (DC_{STEP}) for the control resolution.....	13
• Added parameter symbol (DC_{ON_MIN}) for the minimum-operation duty cycle	14

- Changed "pulse durations" to "duty cycles"..... 14
- Changed PWM_{DC} to PWM_{dc} 14
- Added parameter symbol (f_{FG_MIN}) for the motor speed 15
- Changed the number of lock-detect schemes from five to six 16
- Added a table note stating the required resistor tolerance..... 18
- Added a new *Initial Speed Detect* section..... 19
- Added a parameter symbol (t_{ALIGN}) in the *Align* section, and reworded the last sentence thereof 19
- Changed the column headings of the two rightmost columns in *Table 2*..... 20
- Added three table notes following *Table 2* 20
- Changed "programmed resistor" to "selected resistor" 21
- Added a table note stating the required resistor tolerance..... 22
- Added a table note stating the required resistor tolerance..... 23
- Added a $\pm 30\%$ tolerance to the V1P8 capacitor in *Table 5* 24
- Changed content of Row 4 in *Table 6* to "Motor electrical constant" 25
- Deleted all previous content from the *Detailed Design Procedure* section and replaced it with a reference to the *DRV10974 Tuning Guide* 25
- Changed *Figure 20* 25
- Added location information for the capacitor in the *Power Supply Recommendations* section 26
- Added the *Device Support* section 28

5 Pin Configuration and Functions

PWP PowerPAD™ Package
16-Pin HTSSOP With Exposed Thermal Pad
Top View

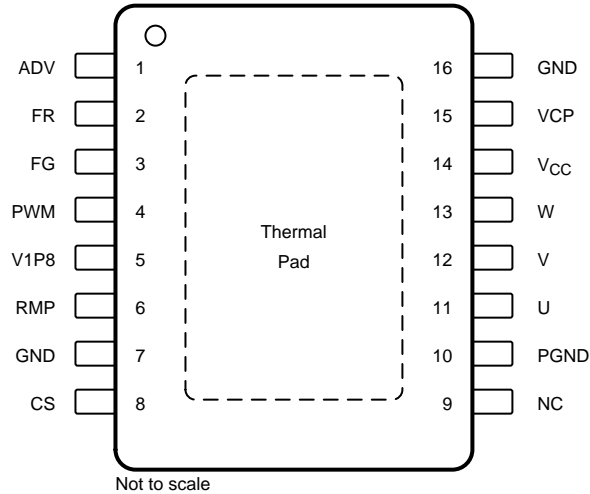

NC – No internal connection

RUM Package
16-Pin WQFN With Exposed Thermal Pad
Top View

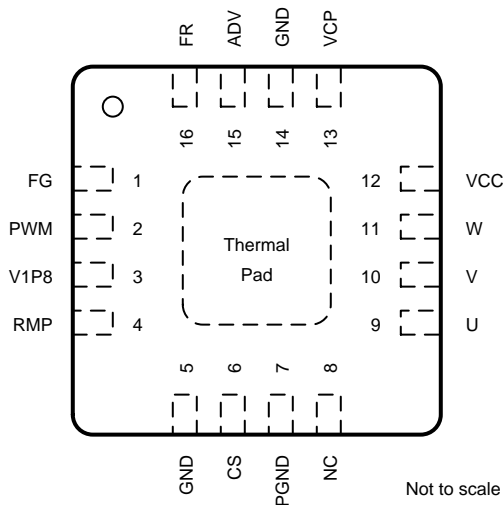

NC – No internal connection

Pin Functions

NAME.	PIN		I/O	TYPE ⁽¹⁾	DESCRIPTION
	NO.				
	HTSSOP	WQFN			
ADV	1	15	I	D	Selects the applied lead angle by 1/8-W resistor; not to be driven externally with a source; leaving the pin open results in the longest lead angle; the lead angle is determined by the ADV pin voltage at power up.
CS	8	6	I	D	Selects current limit by 1/8-W resistor; not to be driven externally with a source; leaving the pin open results in the highest current limit; the current limit is determined by the CS pin voltage at power up.
FG	3	1	O	D	Provides motor speed feedback; open-drain output with internal pullup to V3P3; needs a pullup resistor to limit current if pullup voltage is higher than V3P3
FR	2	16	I	D	Direction control. FR = 0: U→V→W; FR = 1: U→W→V; value is determined by the FR pin state on exit of low-power mode; internal pulldown
GND	7, 16	5, 14	—	—	Digital and analog ground
NC	9	8	—	NC	No internal connection
PGND	10	7	—	P	Power ground connection for motor power
PWM	4	2	I	D	Motor speed-control input; auto detect for analog or digital mode; internal pullup to 2.2 V
RMP	6	4	I	D	Acceleration ramp-rate control; 1/8-W resistor to GND to set acceleration rate; leaving the pin open results in the slowest acceleration rate; the acceleration rate is determined by the RMP pin voltage at power up.
U	11	9	I/O	A	Motor phase U
V	12	10	I/O	A	Motor phase V
V1P8	5	3	O	P	LDO regulator for internal operation; 1-μF, 6.3-V ceramic capacitor tied to GND. Can supply a maximum of 3 mA to an external load.
V _{CC}	14	12	I	P	Power-supply connection; 10-μF, 25-V ceramic capacitor tied to GND
VCP	15	13	O	A	Charge-pump output; 100-nF, 10-V ceramic capacitor tied to V _{CC}
W	13	11	I/O	A	Motor phase W
Thermal pad	—	—	—	—	The exposed thermal pad must be electrically connected to the ground plane by soldering to the PCB for proper operation, and connected to the bottom side of the PCB through vias for better thermal spreading.

(1) I = Input, O = Output, I/O = Input/output, P = Power, D = Digital, A = Analog, NC = No connection

6 Specifications

6.1 Absolute Maximum Ratings

over operating junction temperature range (unless otherwise noted)⁽¹⁾

		MIN	MAX	UNIT
Pin voltage	V _{CC}	-0.3	20	V
	PWM, FR	-0.3	5.5	
	CS, RMP, ADV	-0.3	2	
	GND, PGND	-0.3	0.3	
	U, V, W	-1	20	
	V1P8	-0.3	2	
	FG	-0.3	20	
	VCP	-0.3	V _{CC} + 5.5	
Maximum junction temperature, T _{Jmax}		-40	150	°C
Storage temperature, T _{stg}		-55	150	°C

(1) Stresses beyond those listed under *Absolute Maximum Ratings* may cause permanent damage to the device. These are stress ratings only, which do not imply functional operation of the device at these or any other conditions beyond those indicated under *Recommended Operating Conditions*. Exposure to absolute-maximum-rated conditions for extended periods may affect device reliability.

6.2 ESD Ratings

			VALUE	UNIT
$V_{(ESD)}$	Electrostatic discharge	Human-body model (HBM), per ANSI/ESDA/JEDEC JS-001 ⁽¹⁾	±1000	V
		Charged-device model (CDM), per JEDEC specification JESD22-C101 ⁽²⁾	±500	

(1) JEDEC document JEP155 states that 500-V HBM allows safe manufacturing with a standard ESD control process.

(2) JEDEC document JEP157 states that 250-V CDM allows safe manufacturing with a standard ESD control process.

6.3 Recommended Operating Conditions

over operating junction temperature range (unless otherwise noted)

		MIN	NOM	MAX	UNIT
Supply voltage	V_{CC}	4.4		18	V
Voltage	U, V, W	-0.7		18	V
	PWM, FR	-0.1		5.5	
	FG	0.5		18	
	CS	-0.1		1.8	
	PGND, GND	-0.1		0.1	
	RMP, ADV	-0.1		1.8	
Current	V1P8 regulator-output current; external load	0		3	mA
Operating ambient temperature, T_A		-40		85	°C
Operating junction temperature, T_J		-40		125	°C

6.4 Thermal Information

THERMAL METRIC ⁽¹⁾		DRV10974		UNIT
		PWP (HTSSOP)	RUM (VQFN)	
		16 PINS	16 PINS	
$R_{\theta JA}$	Junction-to-ambient thermal resistance	37.8	34.5	°C/W
$R_{\theta JC(top)}$	Junction-to-case (top) thermal resistance	25.2	27	°C/W
$R_{\theta JB}$	Junction-to-board thermal resistance	20.7	13.3	°C/W
Ψ_{JT}	Junction-to-top characterization parameter	0.7	0.3	°C/W
Ψ_{JB}	Junction-to-board characterization parameter	20.5	13.3	°C/W
$R_{\theta JC(bot)}$	Junction-to-case (bottom) thermal resistance	1.9	4	°C/W

(1) For more information about traditional and new thermal metrics, see [Semiconductor and IC Package Thermal Metrics](#).

6.5 Electrical Characteristics

over operating junction temperature range (unless otherwise noted)

PARAMETER		TEST CONDITIONS	MIN	TYP	MAX	UNIT
SUPPLY CURRENT						
I_{CC}	Supply current	$T_A = 25^\circ\text{C}$, $V_{CC} = 12\text{ V}$, no motor load		5	7	mA
$I_{CC(LP)}$	Low power mode	$T_A = 25^\circ\text{C}$, $V_{CC} = 12\text{ V}$		380		µA
UVLO						
$V_{(UVLO_F)}$	V_{CC} UVLO falling		4.2	4.3	4.4	V
$V_{(UVLO_R)}$	V_{CC} UVLO rising		4.5	4.7	4.85	V
$V_{hys(UVLO)}$	V_{CC} UVLO hysteresis			400		mV
$V_{VCP(UVLO_F)}$	Charge pump UVLO falling	$V_{VCP} - V_{CC}$	3.35	3.7	4.05	V
$V_{VCP(UVLO_R)}$	Charge pump UVLO rising	$V_{VCP} - V_{CC}$	3.65	4.0	4.37	V
$V_{hys(VCP)}$	Charge pump UVLO hysteresis			330		mV
$V_{(V1P8_F)}$	V1P8 UVLO falling		1.25	1.4	1.55	V
$V_{(V1P8_R)}$	V1P8 UVLO rising		1.35	1.5	1.65	V
$V_{hys(V1P8)}$	V1P8 UVLO hysteresis			100		mV
VOLTAGE REGULATORS						

Electrical Characteristics (continued)

over operating junction temperature range (unless otherwise noted)

PARAMETER		TEST CONDITIONS	MIN	TYP	MAX	UNIT
V_{V1P8}	V1P8 voltage	$T_A = 25^\circ\text{C}$, $C_{(V1P8)} = 1\ \mu\text{F}$	1.7	1.8	1.9	V
I_{V1P8}	Maximum external load from V1P8	$T_A = 25^\circ\text{C}$, $C_{(V1P8)} = 1\ \mu\text{F}$			3	mA
INTEGRATED MOSFET						
$r_{ds(on)_HS}$	High-side FET on-resistance	$T_A = 25^\circ\text{C}$, $V_{CC} = 12\ \text{V}$, $I_O = 100\ \text{mA}$		0.375	0.425	Ω
$r_{ds(on)_LS}$	Low-side FET on-resistance	$T_A = 25^\circ\text{C}$, $V_{CC} = 12\ \text{V}$, $I_O = 100\ \text{mA}$		0.375	0.425	Ω
PHASE DRIVER						
SL_{PH_LH}	Phase slew rate switching low to high	SlewRate = 0; measure 20% to 80%; $V_{CC} = 12\ \text{V}$; phase current > 20 mA	70	120	170	V/ μs
SL_{PH_HL}	Phase slew rate switching high to low	SlewRate = 0; measure 80% to 20%; $V_{CC} = 12\ \text{V}$; phase current > 20 mA	70	120	170	V/ μs
f_{PWM_OUT}	Phase output PWM frequency			25		kHz
t_{dead_time}	Recommended dead time		440			ns
CHARGE PUMP						
V_{VCP}	VCP voltage	$V_{CC} = 4.4\ \text{V}$ to $18\ \text{V}$	$V_{CC} + 4$	$V_{CC} + 5$	$V_{CC} + 5.5$	V
CURRENT LIMIT						
I_{LIMIT}	Current-limit threshold	$V_{CC} = 12\ \text{V}$, $R_{(CS)} = 7.32\ \text{k}\Omega \pm 1\%$		0.2		A
		$V_{CC} = 12\ \text{V}$, $R_{(CS)} = 16.2\ \text{k}\Omega \pm 1\%$		0.4		
		$V_{CC} = 12\ \text{V}$, $R_{(CS)} = 25.5\ \text{k}\Omega \pm 1\%$		0.6		
		$V_{CC} = 12\ \text{V}$, $R_{(CS)} = 38.3\ \text{k}\Omega \pm 1\%$		0.8		
		$V_{CC} = 12\ \text{V}$, $R_{(CS)} = 54.9\ \text{k}\Omega \pm 1\%$		1		
		$V_{CC} = 12\ \text{V}$, $R_{(CS)} = 80.6\ \text{k}\Omega \pm 1\%$		1.2		
		$V_{CC} = 12\ \text{V}$, $R_{(CS)} = 115\ \text{k}\Omega \pm 1\%$		1.4		
		$V_{CC} = 12\ \text{V}$, $R_{(CS)} = 182\ \text{k}\Omega \pm 1\%$, open loop and closed loop current limit		1.6		
		$V_{CC} = 12\ \text{V}$, $R_{(CS)} = 182\ \text{k}\Omega \pm 1\%$, align current limit		1.5		
RANGE OF MOTORS SUPPORTED						
R_m	Motor resistance measurement	Phase to center tap	1		20	Ω
K_t	Motor BEMF constant measurement	Phase to center tap	5		150	mV/Hz
t_{ALIGN}	Motor align time			0.67		s

Electrical Characteristics (continued)

over operating junction temperature range (unless otherwise noted)

PARAMETER		TEST CONDITIONS	MIN	TYP	MAX	UNIT
PWM - DIGITAL MODE						
$V_{IH(DIG)}$	PWM input high voltage		2.2			V
$V_{IL(DIG)}$	PWM input low voltage				0.6	V
f_{PWM}	PWM input frequency		0.1		100	kHz
DC_{MAX}	Maximum output PWM duty cycle	$V_{VCC} < 14\text{ V}$		100 %		
		$V_{VCC} \geq 14\text{ V}$		$[(14 / V_{VCC}) \times 100]\%$		
DC_{MIN}	Minimum output PWM duty cycle device needs to guarantee (irrespective of input PWM DC)	Lower duty cycle from 15% down		15%		
DC_{ON_MIN}	Minimum input duty cycle that device uses to drive motor			1.5 %		
DC_{STEP}	Duty cycle step size/resolution			0.2 %		
$V_{IH(AUTO)}$	PWM input high voltage for auto detection		1.62	1.695	1.77	V
$V_{IL(AUTO)}$	PWM input low voltage for exiting PWM mode		1.315	1.39	1.465	V
$R_{pu(PWM)}$	Internal PWM pullup resistor to V3P3			120		k Ω
LOW-POWER MODE						
t_{EX_LPM}	PWM pulse duration to exit low-power mode	$PWM > V_{IH(DIG)}$	1			μs
V_{EX_LPM}	PWM voltage to exit low-power mode		1.5			V
t_{EN_LPM}	PWM low time to enter low-power mode	$PWM < V_{IL(DIG)}$, motor stationary	25			ms
PWM - ANALOG MODE						
V_{ANA_FS}	Analog full-speed voltage			1.8		V
V_{ANA_ZS}	Analog zero-speed voltage		20			mV
$R_{out(PWM)}$	External analog driver output impedance				50	k Ω
t_{SAM}	Analog speed sample period			320		μs
V_{ANA_RES}	Analog voltage resolution			3.5		mV
DIGITAL I/O (FG OUTPUT, FR INPUT)						
f_{FG_MIN}	Minimum FG output frequency during coast			10		Hz
$V_{IH(FR)}$	Input high		2.2			V
$V_{IL(FR)}$	Input low				0.6	V
I_{FG_SINK}	Output sink current, FG	$V_O = 0.3\text{ V}$	5			mA
$R_{pu(FG)}$	Internal FG pullup resistor to 3.3V			20		k Ω
$R_{pd(FR)}$	Internal FR pulldown resistor to ground			100		k Ω
LOCK DETECTION RELEASE TIME						
$t_{(LOCK_OFF)}$	Lock release time			5		s
OVERCURRENT PROTECTION						
I_{OC_limit}	Overcurrent protection	$T_A = 25^\circ\text{C}$	2.5			A
t_{OC_retry}	Overcurrent protection retry time			5		s
THERMAL SHUTDOWN						
T_{SD}	Shutdown temperature threshold		140	150		$^\circ\text{C}$
$T_{SD(hys)}$	Shutdown temperature threshold hysteresis			15		$^\circ\text{C}$

Electrical Characteristics (continued)

over operating junction temperature range (unless otherwise noted)

PARAMETER		TEST CONDITIONS	MIN	TYP	MAX	UNIT
LEAD ANGLE						
ADV _{select}	Lead angle selection	V _{CC} = 12 V, R _(ADV) = 10.7 kΩ ±1%		10		μs
		V _{CC} = 12 V, R _(ADV) = 14.3 kΩ ±1%		25		
		V _{CC} = 12 V, R _(ADV) = 17.8 kΩ ±1%		50		
		V _{CC} = 12 V, R _(ADV) = 22.1 kΩ ±1%		100		
		V _{CC} = 12 V, R _(ADV) = 28 kΩ ±1%		150		
		V _{CC} = 12 V, R _(ADV) = 34 kΩ ±1%		200		
		V _{CC} = 12 V, R _(ADV) = 41.2 kΩ ±1%		250		
		V _{CC} = 12 V, R _(ADV) = 49.9 kΩ ±1%		300		
		V _{CC} = 12 V, R _(ADV) = 59 kΩ ±1%		400		
		V _{CC} = 12 V, R _(ADV) = 71.5 kΩ ±1%		500		
		V _{CC} = 12 V, R _(ADV) = 86.6 kΩ ±1%		600		
		V _{CC} = 12 V, R _(ADV) = 105 kΩ ±1%		700		
		V _{CC} = 12 V, R _(ADV) = 124 kΩ ±1%		800		
		V _{CC} = 12 V, R _(ADV) = 150 kΩ ±1%		900		
V _{CC} = 12 V, R _(ADV) = 182 kΩ ±1%		1000				
ACCELERATION RAMP RATE						
RMP _{select}	RMP selection for acceleration profile	V _{CC} = 12 V, R _(RMP) = 7.32 kΩ ±1%		0		code
		V _{CC} = 12 V, R _(RMP) = 10.7 kΩ ±1%		1		
		V _{CC} = 12 V, R _(RMP) = 14.3 kΩ ±1%		2		
		V _{CC} = 12 V, R _(RMP) = 17.8 kΩ ±1%		3		
		V _{CC} = 12 V, R _(RMP) = 22.1 kΩ ±1%		4		
		V _{CC} = 12 V, R _(RMP) = 28 kΩ ±1%		5		
		V _{CC} = 12 V, R _(RMP) = 34 kΩ ±1%		6		
		V _{CC} = 12 V, R _(RMP) = 41.2 kΩ ±1%		7		
		V _{CC} = 12 V, R _(RMP) = 49.9 kΩ ±1%		8		
		V _{CC} = 12 V, R _(RMP) = 59 kΩ ±1%		9		
		V _{CC} = 12 V, R _(RMP) = 71.5 kΩ ±1%		10		
		V _{CC} = 12 V, R _(RMP) = 86.6 kΩ ±1%		11		
		V _{CC} = 12 V, R _(RMP) = 105 kΩ ±1%		12		
		V _{CC} = 12 V, R _(RMP) = 124 kΩ ±1%		13		
		V _{CC} = 12 V, R _(RMP) = 150 kΩ ±1%		14		
V _{CC} = 12 V, R _(RMP) = 182 kΩ ±1%		15				

6.6 Typical Characteristics

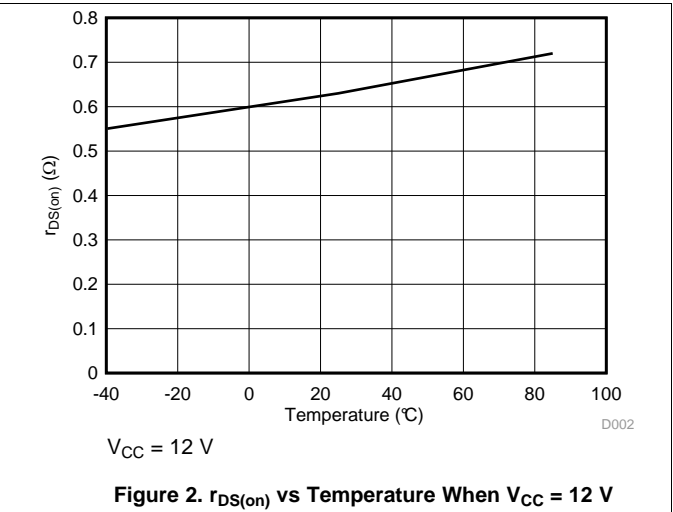
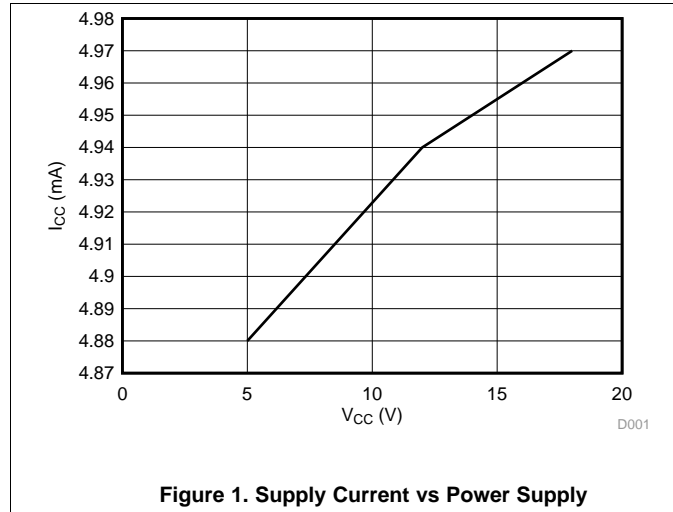

7 Detailed Description

7.1 Overview

The DRV10974 device is a three-phase sensorless motor driver with integrated power MOSFETs, which provide drive-current capability up to 1 A continuous (rms). The device is specifically designed for low-noise, low external-component count, 12-V motor-drive applications. The 180° commutation requires no configuration beyond setting the peak current, the lead angle, and the acceleration profile, each of which is configured by an external resistor.

The 180° sensorless-control scheme provides sinusoidal output voltages to the motor phases as shown in Figure 3.

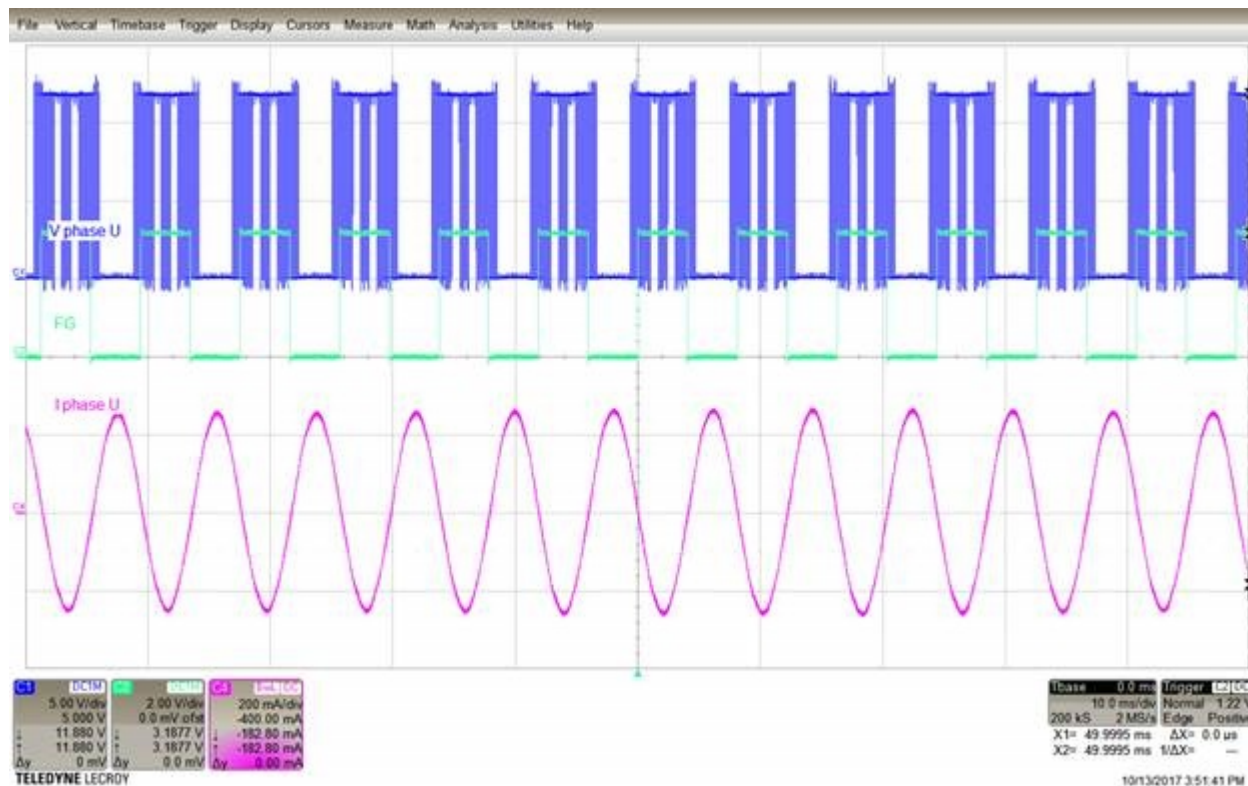
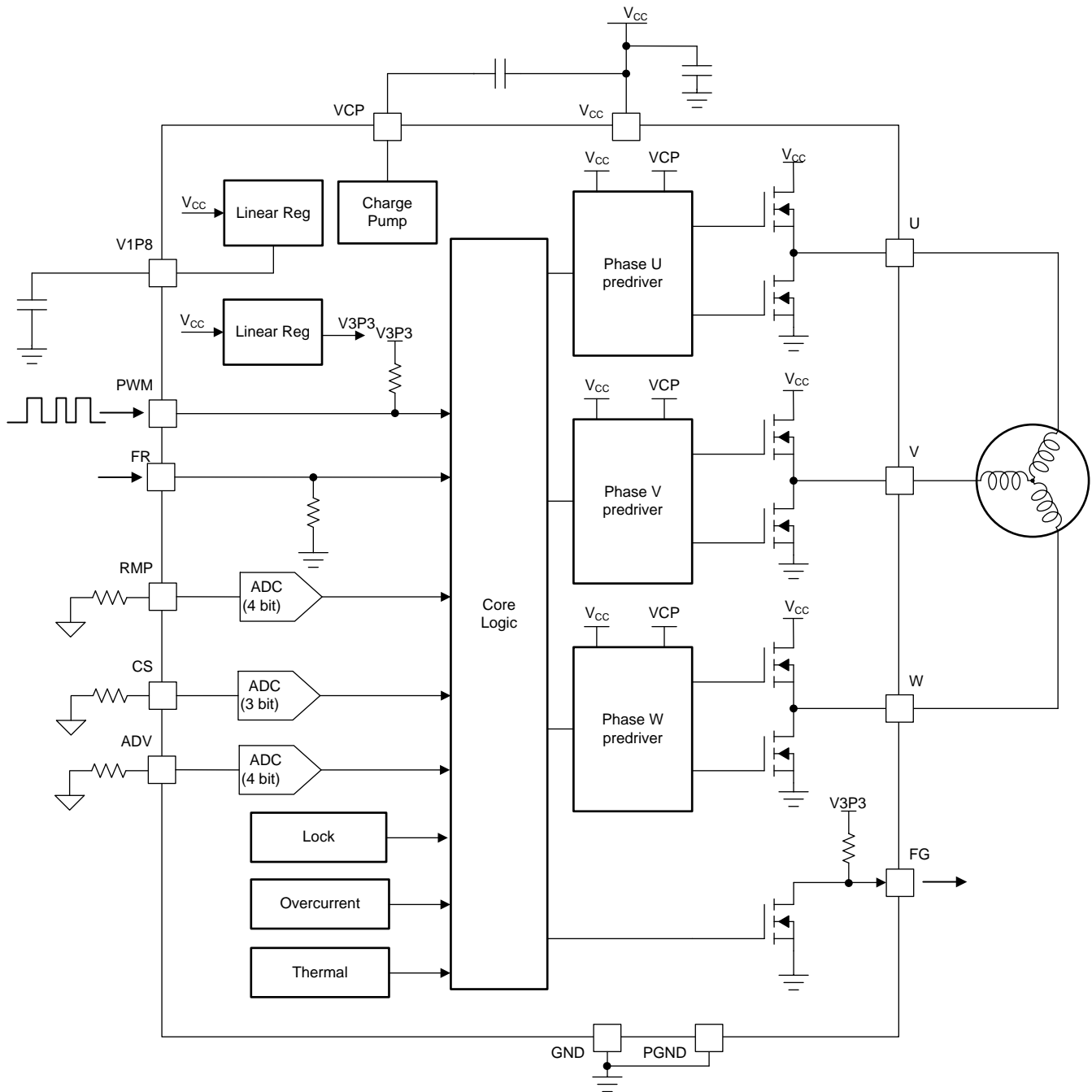

Figure 3. 180° Sensorless-Control Scheme

Interfacing to the DRV10974 device is simple and intuitive. The DRV10974 device receives a PWM input that it uses to control the speed of the motor. The duty cycle of the PWM input is used to determine the magnitude of the voltage applied to the motor. The resulting motor speed can be monitored on the FG pin. The FR pin is used to control the direction of rotation for the motor. The acceleration ramp rate is controlled by the RMP pin. The current limit is controlled by a resistor on the CS pin. The lead angle is controlled by a resistor on the ADV pin. When the motor is not spinning, a low-power mode turns off unused circuits to conserve power.

The DRV10974 device features extensive protection and fault-detect mechanisms to ensure reliable operation. The device provides overcurrent protection without the requirement for an external current-sense resistor. Rotor-lock detect uses several methods to reliably determine when the rotor stops spinning unexpectedly. The device provides additional protection for undervoltage lockout (UVLO), for thermal shutdown, and for phase short circuit (phase to phase, phase to ground, phase to supply).

7.2 Functional Block Diagram



Copyright © 2017, Texas Instruments Incorporated

7.3 Feature Description

7.3.1 Speed Input and Control

The DRV10974 device has a three-phase 25-kHz PWM (f_{PWM_OUT}) output that has an average value of sinusoidal waveforms from phase to phase as shown in [Figure 4](#). When any phase is measured with reference to ground, the waveform observed is a PWM-encoded sinusoid coupled with third-order harmonics as shown in [Figure 5](#). This encoding scheme simplifies the driver requirements because one phase output is always equal to zero.

Feature Description (continued)

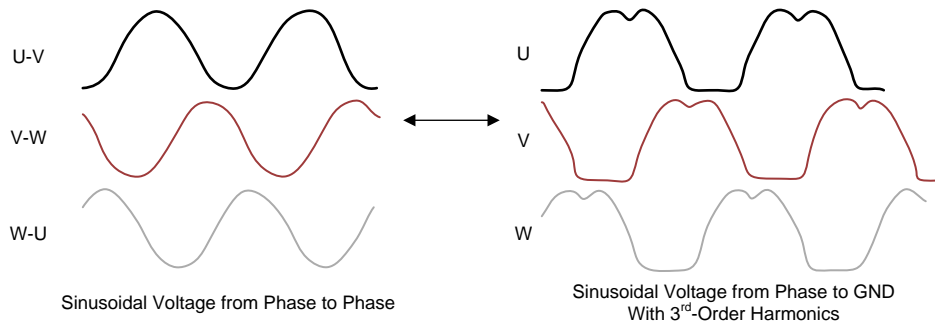

Figure 4. Sinusoidal Voltage

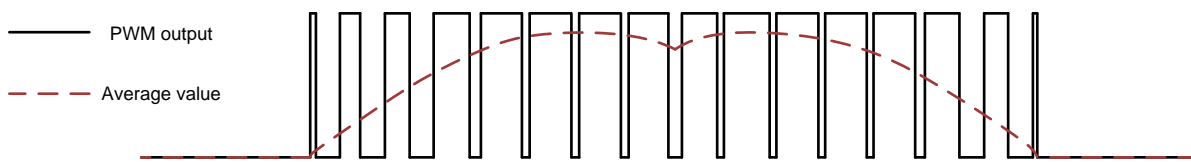

Figure 5. PWM Encoded Phase Output and the Average Value

The output amplitude is determined by the supply voltage (V_{CC}) and the PWM-commanded duty cycle (PWM) as calculated in Equation 1 and shown in Figure 6. The maximum amplitude is applied when the commanded PWM duty cycle is slightly less than 100% in order to keep the 25-kHz PWM rate (f_{PWM_OUT}).

$$V_{ph_pk} = PWM_{dc} \times V_{CC} \tag{1}$$

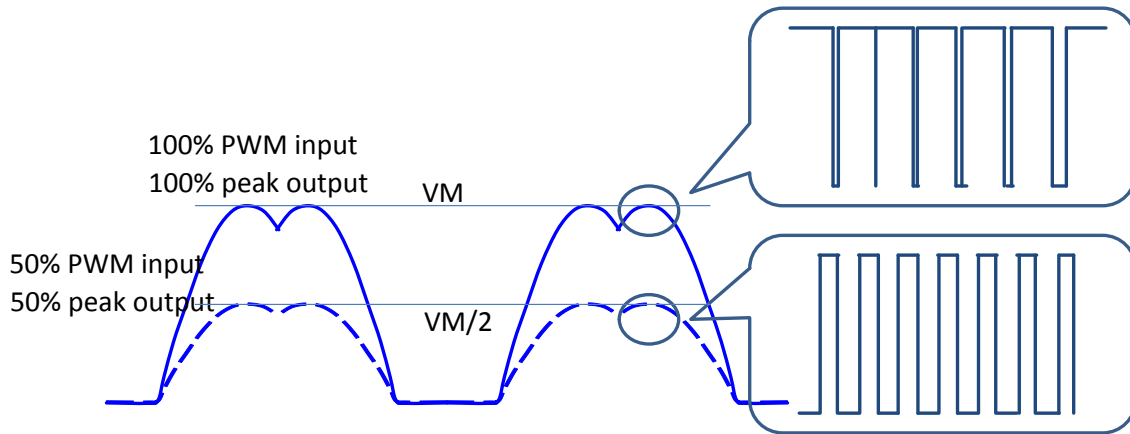

Figure 6. Output Voltage Amplitude Adjustment

The motor speed is controlled indirectly by using the PWM command to control the amplitude of the phase voltages which are applied to the motor. The PWM pin can be driven by either a digital duty cycle or an analog voltage.

The duty cycle of the PWM input (PWM) is passed through a low-pass filter that ramps from 0% to 100% duty cycle in 120 ms. The control resolution is approximately 0.2% (DC_{STEP}). The signal path from PWM input to PWM motor is shown in Figure 7.

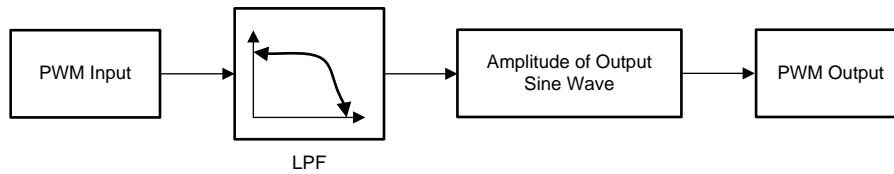

Figure 7. PWM Command Input Control Diagram

The output peak amplitude is described by Equation 1 when $PWM_{dc} > 15\%$ (the minimum-operation duty cycle). When the PWM-commanded duty cycle is lower than the minimum-operation duty cycle and higher than 1.5% (DC_{ON_MIN}), the output is controlled by the minimum-operation duty cycle (DC_{MIN}). This is shown in Figure 8 for analog input, and for duty cycles greater than 1.5% (DC_{ON_MIN}) for digital input. If the supply voltage (V_{VCC}) > 14 V, the maximum PWM_{dc} is limited to $14 V / V_{VCC}$.

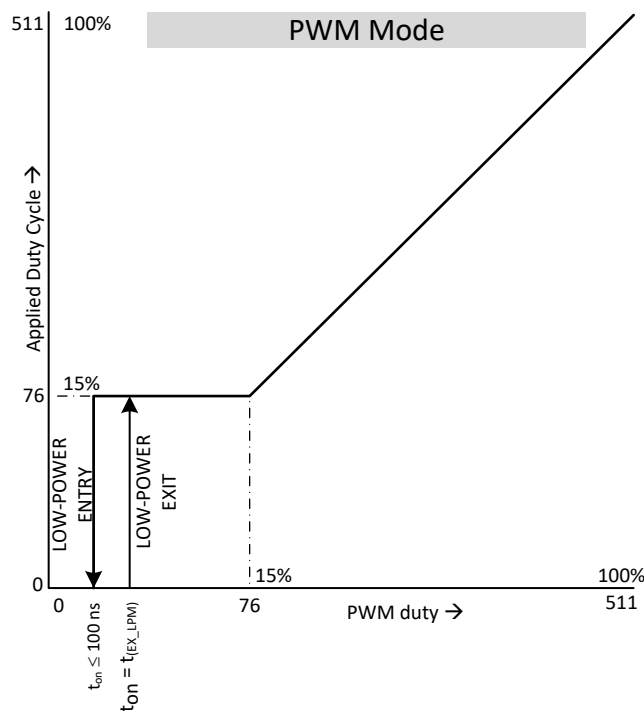

Figure 8. PWM-Mode Speed-Control Transfer Function

When the PWM pin is driven with an analog voltage, the output peak amplitude depends on the supply voltage, the analog voltage on the PWM pin (V_{ANA}), and the voltage of V1P8 (V_{V1P8}). This is shown in Equation 2:

$$V_{ph_pk} = \frac{V_{ANA}}{V_{1P8}} \times V_{CC} \tag{2}$$

Note the output peak amplitude is described by Equation 2 when the $V_{ANA} > 0.27 V$ or 15% of 1.8 V. This is the equivalent of the minimum-operation duty cycle percentage of 15% (DC_{MIN}). When the analog voltage on the PWM pin is lower than the minimum-operation duty-cycle percentage but higher than the zero-speed analog voltage (V_{ANA_ZS}), the output is controlled by the minimum-operation duty cycle. When the analog voltage on the PWM pin is below zero-speed analog voltage, the DRV10974 enters low-power mode. This is shown in Figure 9.

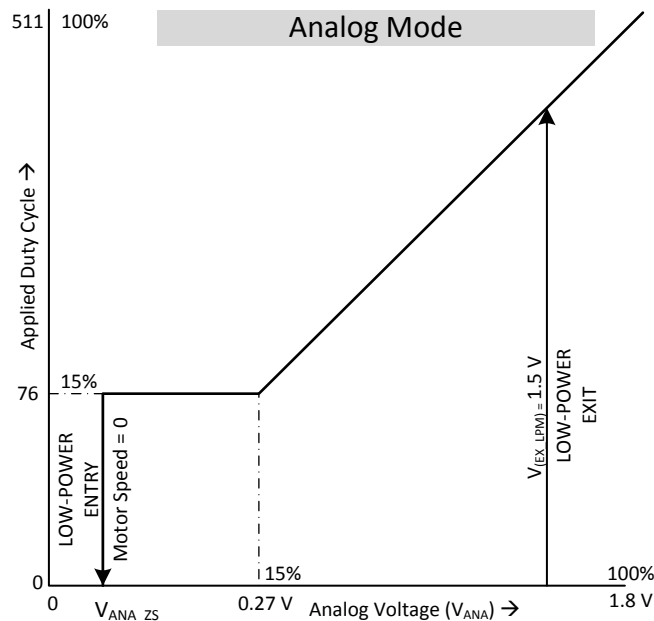

Figure 9. Analog-Mode Speed-Control Transfer Function

7.3.2 Motor Direction Change

The DRV10974 device can be easily configured to drive the motor in either direction by setting the input on the FR (forward-reverse) pin to a logic 1 or logic 0 state. The direction of commutation as described by the commutation sequence is defined as follows:

FR = 0 U → V → W

FR = 1 U → W → V

7.3.3 Motor-Frequency Feedback (FG)

During operation of the DRV10974 device, the FG pin provides an indication of the speed of the motor. The FG pin toggles at a rate of one time during an electrical cycle. Using this information and the number of pole pairs in the motor, use Equation 3 to calculate the mechanical speed of the motor.

$$\text{RPM} = \frac{f_{(\text{FG})} \times 60}{\text{pole_pairs}} \quad (3)$$

During open-loop acceleration the FG pin indicates the frequency of the signal that is driving the motor. The lock condition of the motor is unknown during open-loop acceleration and therefore the FG pin could toggle during this time even though the motor is not moving.

During spin down, the DRV10974 device continues to provide speed feedback on the FG pin. The DRV10974 device provides the output of the U-phase comparator on the FG pin until the motor speed drops below 10 Hz ($f_{\text{FG_MIN}}$). When the motor speed falls below 10 Hz, the device enters into the low-power mode and the FG output is held at a logic high.

7.3.4 Lock Detection

When the motor is locked by some external condition, the DRV10974 device detects the lock condition and acts to protect the motor and the device. The lock condition must be properly detected whether the condition occurs as a result of a slowly increasing load or a sudden shock.

The DRV10974 device reacts to the lock condition by stopping the motor drive. To stop driving the motor, the phase outputs are placed into a high-impedance state. After successfully transitioning into a high-impedance state as the result of a lock condition, the DRV10974 device attempts to restart the motor after $t_{(\text{LOCK_OFF})}$ seconds.

The DRV10974 device has a comprehensive lock-detect function that includes six different lock-detect schemes. Each of these schemes detects a particular condition of the lock as shown in Figure 10.

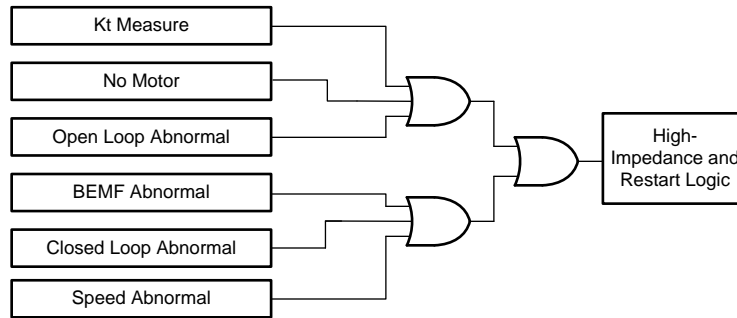

Figure 10. Lock Detect

The following sections describe each lock-detect scheme.

7.3.4.1 Lock Kt Measure

The DRV10974 device measures the actual Kt of the motor when transitioning from open-loop acceleration to closed-loop acceleration. If the measured Kt is less than 200 mV, the device indicates that the handoff Kt level was not properly reached and the lock is triggered.

7.3.4.2 Lock No Motor

The phase-U current is checked at the end of the align state. If the phase-U current is not greater than 50 mA, then the motor is not connected. This condition is reported as a lock condition.

7.3.4.3 Lock Open Loop Abnormal

Transition from open loop to closed loop is based on the estimated value of BEMF. If during open-loop acceleration the electrical commutation rate exceeds 200 Hz without reaching the handoff threshold, this lock is triggered.

7.3.4.4 Lock BEMF Abnormal

For any specific motor, the integrated value of BEMF during half of an electrical cycle is a constant as shown by the shaded gray area in Figure 11. This value is constant regardless of whether the motor runs fast or slow. The DRV10974 device monitors this value and uses it as a criterion to determine if the motor is in a lock condition.

The DRV10974 device uses the integrated BEMF to determine the Kt value of the motor during the initial motor start. Based on this measurement, a range of acceptable Kt values is established. Then, during closed-loop motor operation the Ktc (Kt calculated) value is continuously updated. Finally, the Ktc value is checked to see if it is within the range between 1/2 Kt and 2Kt. If the Ktc value goes beyond the acceptable range, a lock condition is triggered as shown in Figure 12. Note, there is a blanking period of 0.3 s after the transition from open loop to closed loop where the abnormal BEMF lock is momentarily disabled. The device uses this time to finalize the Kt value that Ktc is compared against.

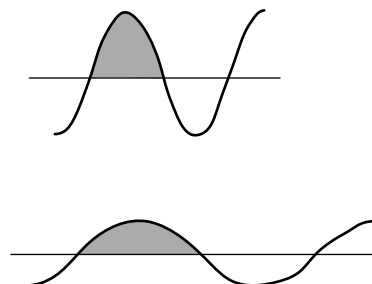

Figure 11. BEMF Integration

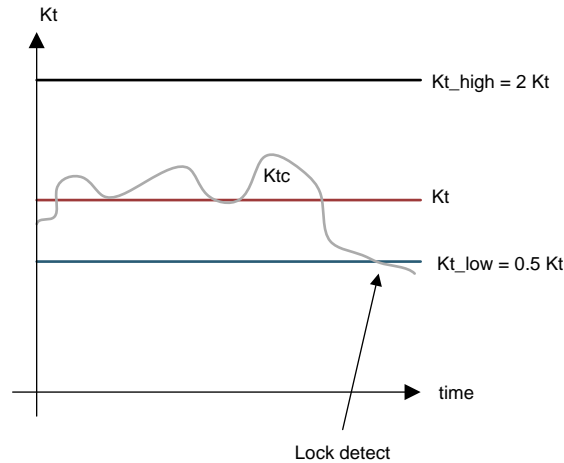

Figure 12. Abnormal Kt Lock Detect

7.3.4.5 Lock Closed Loop Abnormal

This lock condition is active when the DRV10974 device is operating in the closed-loop mode. The motor is indicated as not moving when the closed-loop commutation period becomes lower than half the previous commutation period. This condition triggers the closed-loop abnormal-lock condition.

7.3.4.6 Lock Speed Abnormal

If the motor is in normal operation, the motor BEMF is always less than the voltage applied to the phase. The sensorless-control algorithm of the DRV10974 device is continuously updating the value of the motor BEMF based on the speed of the motor and the motor Kt as shown in Figure 13. If the calculated value for motor BEMF is 1.5 times higher than the applied voltage on phase U (V_U) for an electrical period then an error is present in the system, and the calculated value for motor BEMF is wrong or the motor is out of phase with the commutation logic. When this condition is detected, a lock is triggered.

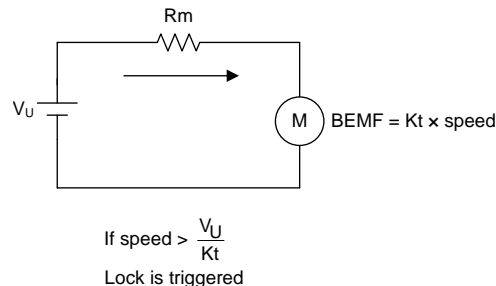

Figure 13. BEMF Monitoring

7.3.5 Soft Current-Limit

The current-limit function provides active protection for preventing damage as a result of high current. The soft current-limit does not use direct-current measurement for protection, but rather, uses the measured motor resistance (R_m) and motor velocity constant (K_t) to limit the voltage applied to the phase (U) such that the current does not exceed the limit value ($I_{(LIMIT)}$). The soft current-limit scheme is shown in Figure 14 based on the calculation in Equation 4.

The soft current-limit is only active when in normal closed-loop mode and does not result in a fault condition nor does it result in the motor being stopped. The soft current-limit is typically useful for limiting the current that results from heavy loading during motor acceleration. The $I_{(LIMIT)}$ current is configured by an external resistor ($R_{(CS)}$) as shown in Table 1.

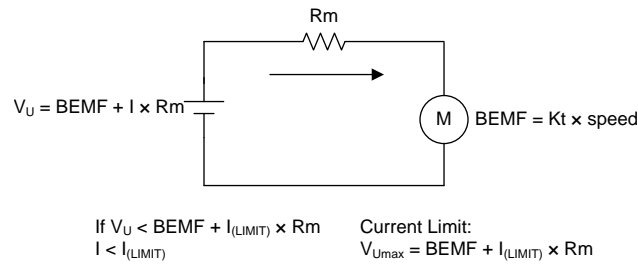

Figure 14. Current Limit

Use Equation 4 to calculate the $I_{(LIMIT)}$ value.

$$I_{(LIMIT)} = \frac{V_{(U)LIMIT} - \text{Speed} \times K_t}{R_m} \tag{4}$$

Table 1 can be used to determine the $I_{(LIMIT)}$ value.

Table 1. Soft Current-Limit Selections

$R_{(CS)}$ [kΩ] ⁽¹⁾	$I_{(LIMIT)}$ [mA]
7.32	200
16.2	400
25.5	600
38.3	800
54.9	1000
80.6	1200
115	1400
182	1600 (1500 during align)

(1) All resistors are ±1 %.

NOTE

The soft current-limit is not correct if the motor is out of phase with the commutation control logic (locked rotor). The soft current-limit is not effective under this condition.

7.3.6 Short-Circuit Current Protection

The short-circuit current protection function shuts off drive to the motor by placing the motor phases into a high-impedance state if the current in any motor phase exceeds the short-circuit protection limit $I_{(OC_LIMIT)}$. The DRV10974 device goes through the initialization sequence and attempts to restart the motor after the short-circuit condition is improved. This function is intended to protect the device and the motor from catastrophic failure when subjected to a short-circuit condition.

7.3.7 Overtemperature Protection

The DRV10974 device has a thermal shutdown function which disables the motor operation when the device junction temperature has exceeded the T_{SD} temperature. Motor operation resumes when the junction temperature becomes lower than $T_{SD} - T_{SD(hys)}$.

7.3.8 Undervoltage Protection

The DRV10974 device has an undervoltage lockout feature, which prevents motor operation whenever the supply voltage (V_{CC}) becomes too low. Upon power up, the DRV10974 device operates when V_{CC} rises above $V_{(UVLO_F)} + V_{hys(UVLO)}$. The DRV10974 device continues to operate until V_{CC} falls below $V_{(UVLO_F)}$.

7.4 Device Functional Modes

7.4.1 Spin-Up Settings

7.4.1.1 Motor Start

The DRV10974 device starts the motor using a procedure which is shown in Figure 15.

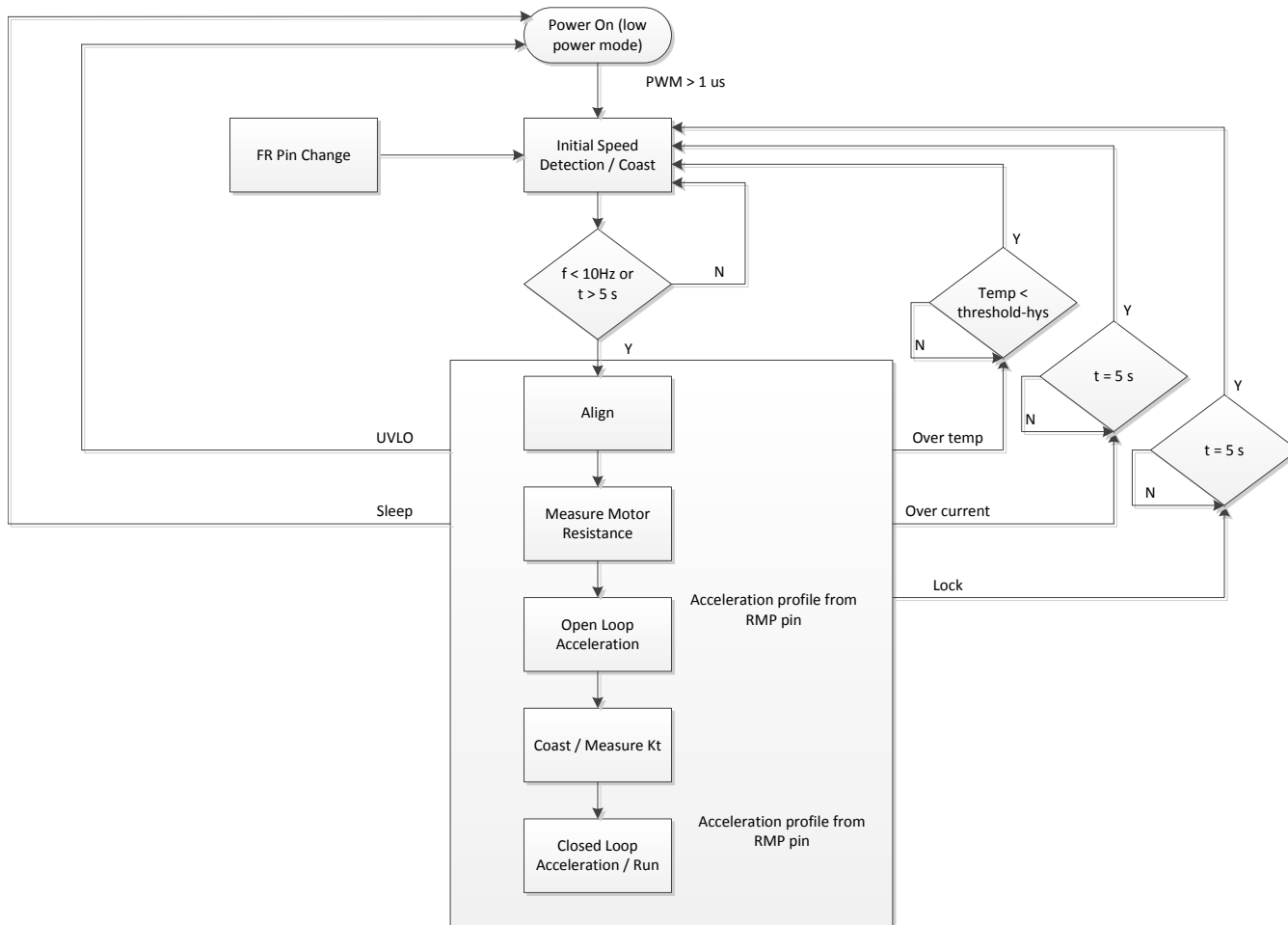

Figure 15. DRV10974 Initialization and Motor Start-Up Sequence

7.4.1.2 Initial Speed Detect

Every time the DRV10974 device exits low-power mode, it determines if the motor is spinning using a function called initial speed detect. If the frequency on the FG pin is less than 10 Hz, the motor is considered stationary. If the frequency is greater than 10 Hz the motor is decelerated until it is below 10 Hz or a 5-second time-out has occurred.

7.4.1.3 Align

To align the rotor to the commutation logic, the DRV10974 device applies a current equivalent to the closed-loop run current to phase U by driving phases V and W equally. This condition is maintained for a maximum of 0.67 s (t_{ALIGN}). To avoid a sudden change in current that could result in undesirable acoustics, the voltage applied to the motor is changed gradually to obtain a current change of 12 A/s.

Device Functional Modes (continued)

7.4.2 Open-Loop Acceleration

After the motor is confirmed to be stationary and after completing the motor initialization, the DRV10974 device begins to accelerate the motor. This acceleration is accomplished by applying a voltage to the motor at the appropriate drive state and increasing the rate of commutation without regard to the actual position of the motor (referred to as *open-loop operation*). The function of the open-loop operation is to drive the motor to a minimum speed so that the motor generates sufficient BEMF to allow the commutation control logic to drive the motor accurately.

The motor start-up profile can be configured using an external resistor to set the acceleration profile before transitioning to closed-loop operation. [Figure 16](#) shows this acceleration profile. During closed-loop operation the RMP pin controls the closed-loop acceleration and deceleration. [Table 2](#) lists the selectable acceleration parameters.

Table 2. Acceleration Profile Settings

RMP SELECTION	R _{RMP} [kΩ] ⁽¹⁾	Accel2 [Hz/s ²]	Accel1 [Hz/s]	CLOSED-LOOP-ACCELERATION TRANSITION TIME [s] ⁽²⁾	CLOSED-LOOP-DECELERATION TRANSITION TIME [s] ⁽³⁾
0	7.32	0.22	4.6	2.7	44
1	10.7	1.65	9.2	2.7	22
2	14.3	1.65	15	1	22
3	17.8	3.3	25	1	11
4	22.1	7	25	0.2	44
5	28	7	35	0.2	22
6	34	14	50	0.2	22
7	41.2	27	75	0.2	11
8	49.9	27	75	5.4	11
9	59	14	50	8	22
10	71.5	7	35	11	22
11	86.6	7	25	22	44
12	105	3.3	25	5.4	11
13	124	1.65	15	8	22
14	150	1.65	9.2	11	22
15	182	0.22	4.6	22	44

(1) All resistors are ±1%

(2) Time to transition from 0 to 100% duty cycle.

(3) Time to transition from 100% to 0% duty cycle.

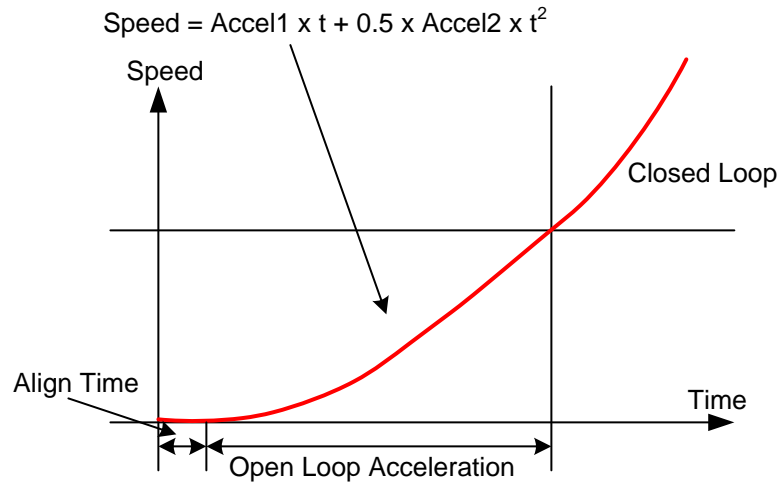

Figure 16. Start-Up Profile

7.4.3 Start-Up Current Sensing

The start-up peak current is controlled by the current-sense limit resistor, $R_{(CS)}$. The start current is set by selecting the $R_{(CS)}$ resistor based on [Table 3](#). The current should be selected to allow the motor to accelerate reliably to the handoff threshold. Heavier loads may require a higher current setting, but the rate of acceleration is limited by the selected resistor, $R_{(RMP)}$.

Table 3. Start-Up Current Limit

$R_{(CS)}$ [k Ω] ⁽¹⁾	$I_{(LIMIT)}$ [mA]
7.32	200
16.2	400
25.5	600
38.3	800
54.9	1000
80.6	1200
115	1400
182	1600 (1500 for align)

(1) All resistors are $\pm 1\%$.

7.4.4 Closed Loop

When the motor accelerates to the target BEMF threshold, commutation control transitions from open-loop mode to closed-loop mode. During this transition, the motor is allowed to coast for one electrical cycle to measure K_t . The commutation drive sequence and timing are determined by the internal control algorithm, and the applied voltage is determined by the PWM-commanded duty-cycle input. The closed-loop acceleration and deceleration values are provided in [Table 2](#).

7.4.5 Control Advance Angle

To achieve the best efficiency, the drive state of the motor must be controlled such that the current is aligned with the BEMF voltage of the motor. [Figure 17](#) illustrates the operation when the drive angle has been optimized. For complete flexibility, the DRV10974 device offers a wide range of fixed lead times. The options for lead time are controlled by a resistor on the ADV pin. The values available are shown in [Table 4](#).

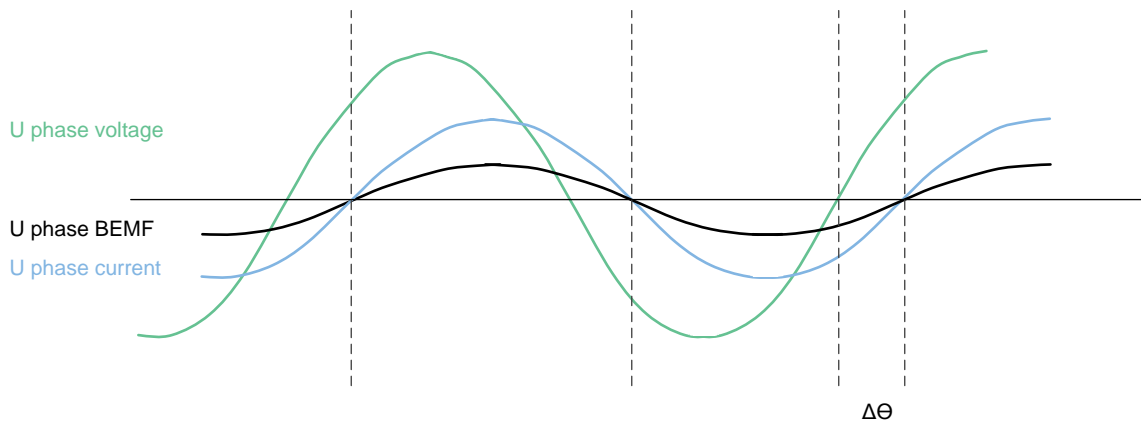

Figure 17. Drive Angle Adjustment

Table 4. Lead Time Selection

R_{ADV} [k Ω] ⁽¹⁾	LEAD TIME [μ s]
10.7	10
14.3	25
17.8	50
22.1	100
28	150
34	200
41.2	250
49.9	300
59	400
71.5	500
86.6	600
105	700
124	800
150	900
182	1000

(1) All resistors are $\pm 1\%$.

8 Application and Implementation

NOTE

Information in the following applications sections is not part of the TI component specification, and TI does not warrant its accuracy or completeness. TI's customers are responsible for determining suitability of components for their purposes. Customers should validate and test their design implementation to confirm system functionality.

8.1 Application Information

The DRV10974 device is used in sensorless 3-phase BLDC motor control. The driver provides a high-performance, high-reliability, flexible, and simple solution for appliance fan, pump, and blower applications. The following design shows a common application of the DRV10974 device.

8.2 Typical Application

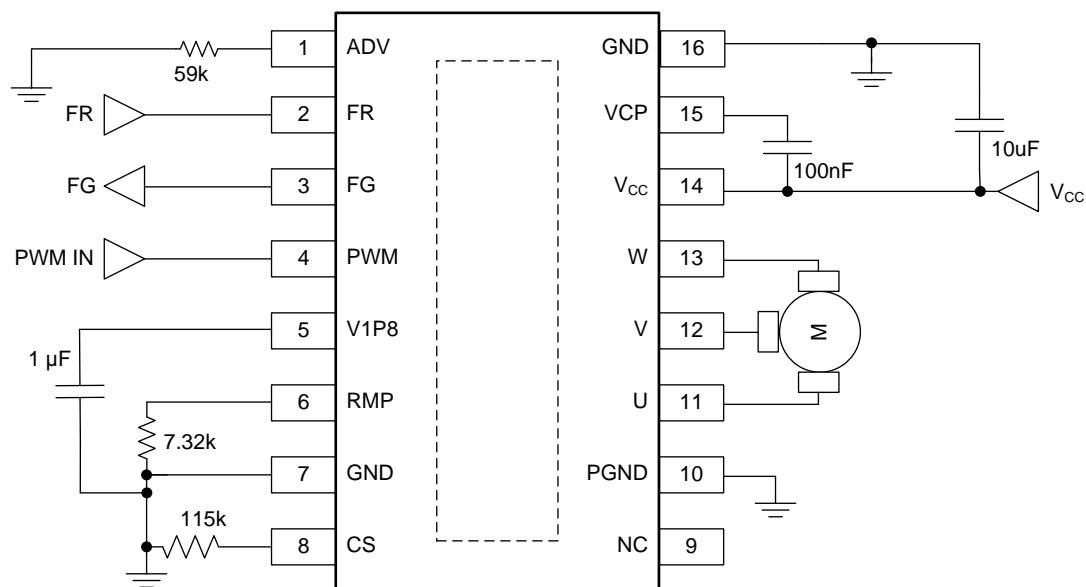

Figure 18. Typical Application Schematic

Table 5. Recommended External Components

NODE 1	NODE 2	COMPONENT
V _{CC}	GND	10-µF, 25-V ceramic capacitor tied from V _{CC} to ground
VCP	V _{CC}	100-nF, 10-V ceramic capacitor tied from VCP to V _{CC}
V1P8	GND	1-µF ±30%, 6.3-V ceramic capacitor tied from V1P8 to ground
RMP	GND	1%, 1/8 watt resistor tied from RMP to ground to set the desired acceleration profile
CS	GND	1%, 1/8-watt resistor tied from CS to ground to set the desired current limit
ADV	GND	1%, 1/8-watt resistor tied from ADV to ground to set the desired lead angle (time)

8.2.1 Design Requirements

Table 6 provides design input parameters and motor parameters for system design.

Table 6. Recommended Application Range

		MIN	NOM	MAX	UNIT
Motor voltage		4.4	12	18	V
BEMF constant	Phase to center tap, measured while motor is coasting	5		150	mV/Hz
Motor phase resistance	Phase to center tap	1		20	Ω
Motor electrical constant	1 phase; inductance divided by resistance, measured phase to phase, yields the electrical constant for 1 phase.	100		5000	μ s
Motor winding current (rms)				1	A
Absolute maximum current	During locked condition			2.5	A

8.2.2 Detailed Design Procedure

Assuming the motor used in the application falls within the recommended application range shown in Table 6, the DRV10974 device is simple and intuitive to interface with. The DRV10974 device receives a PWM input that it uses to control the speed of the motor. The duty cycle of the PWM input is used to determine the magnitude of the voltage applied to the motor. The resulting motor speed can be monitored on the FG pin. The FR pin is used to control the direction of rotation for the motor. As a result, the only configuration and customization is dictated by the RMP, ADV, and CS pins.

The resistor on the CS pin is usually determined by the application specifications. Because the CS pin determines the current limit, specifications such as motor current or input power can determine what value the current limit can be set to. Then, the RMP and ADV resistors must be set experimentally through tuning. The RMP pin sets the acceleration profile of the motor. If the RMP pin is set to faster acceleration, the motor starts up faster but may be more likely to fail start-up. In addition, the ADV resistor controls the lead time so the applied current is aligned with the BEMF of the motor. If the ADV resistor is incorrectly selected, the motor may not run efficiently or at all.

As a result, the RMP pin is usually set to the slowest profile while ADV is correctly tuned. Then, the RMP can be set to a different value that allows for a faster acceleration with no impact to start-up reliability. This process, and other design considerations, are documented extensively in the DRV10974 Technical Documents tab on the DRV10974 product page.

8.2.3 Application Curves

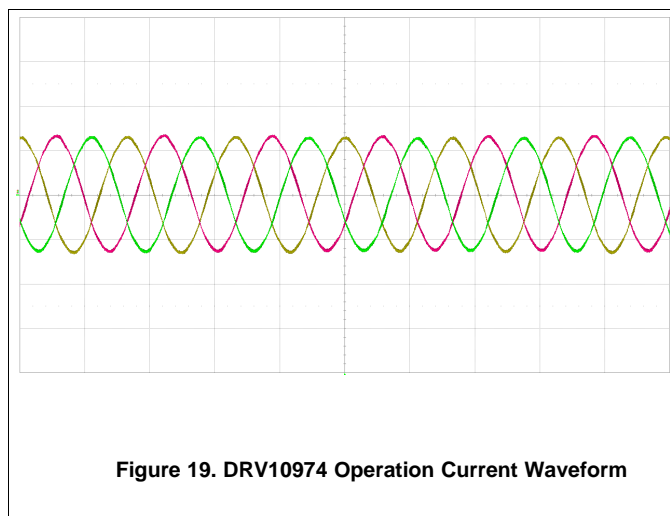

Figure 19. DRV10974 Operation Current Waveform

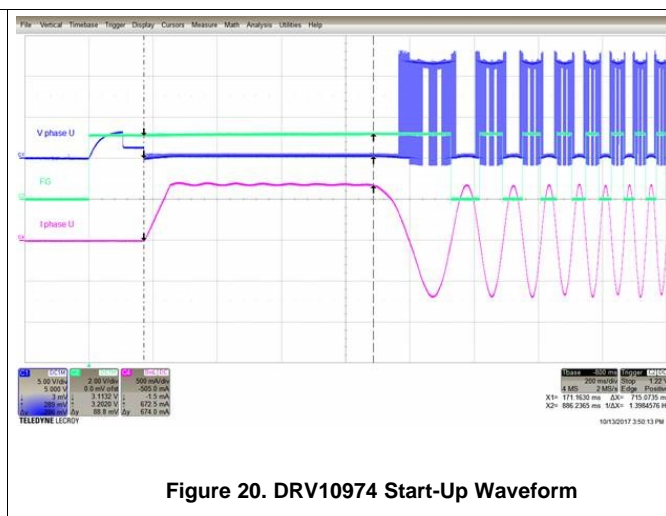

Figure 20. DRV10974 Start-Up Waveform

9 Power Supply Recommendations

The DRV10974 device is designed to operate from an input voltage supply, V_{CC} , range between 4.4 V and 18 V. The user must place a minimum of a 10- μ F capacitor rated for V_{CC} between the V_{CC} and GND pins and as close as possible to the V_{CC} and GND pins.

If the power supply ripple is more than 200 mV, in addition to the local decoupling capacitors, a bulk capacitance is required and must be sized according to the application requirements.

10 Layout

10.1 Layout Guidelines

- Use thick traces when routing to the V_{CC} , GND, U, V, and W pins, because high current passes through these traces.
- Place the 10- μ F capacitor between V_{CC} and GND, and as close to the V_{CC} and GND pins as possible.
- Place the 100-nF capacitor between VCP and V_{CC} , and as close to the VCP and V_{CC} pins as possible.
- Connect GND and PGND under the thermal pad.
- Keep the thermal pad connection as large as possible. It should be one piece of copper without any gaps.

10.2 Layout Example

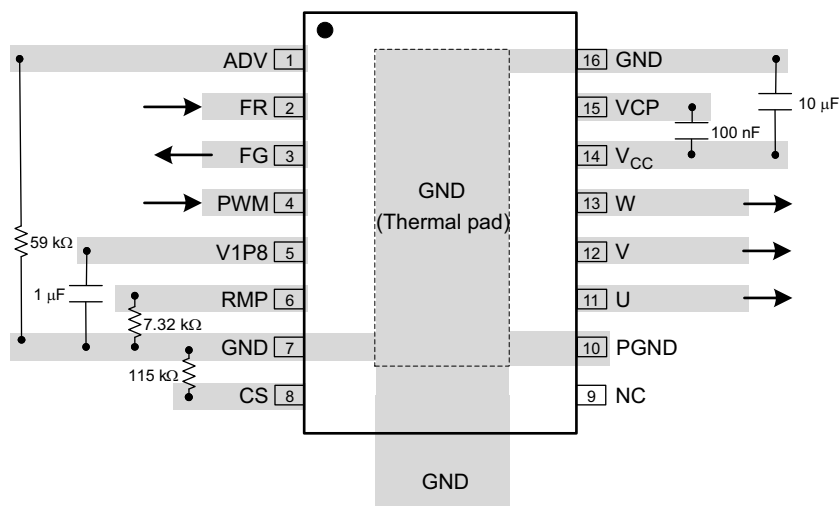

Figure 21. HTSSOP Layout Example

Layout Example (continued)

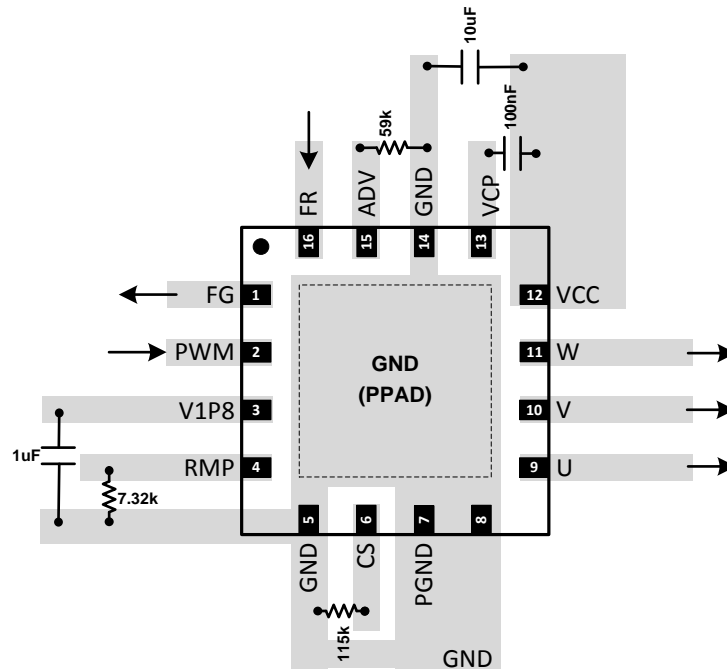

Figure 22. QFN Layout Example

11 Device and Documentation Support

11.1 Device Support

11.1.1 Third-Party Products Disclaimer

TI'S PUBLICATION OF INFORMATION REGARDING THIRD-PARTY PRODUCTS OR SERVICES DOES NOT CONSTITUTE AN ENDORSEMENT REGARDING THE SUITABILITY OF SUCH PRODUCTS OR SERVICES OR A WARRANTY, REPRESENTATION OR ENDORSEMENT OF SUCH PRODUCTS OR SERVICES, EITHER ALONE OR IN COMBINATION WITH ANY TI PRODUCT OR SERVICE.

11.2 Receiving Notification of Documentation Updates

To receive notification of documentation updates, navigate to the device product folder on ti.com. In the upper right corner, click on *Alert me* to register and receive a weekly digest of any product information that has changed. For change details, review the revision history included in any revised document.

11.3 Community Resources

The following links connect to TI community resources. Linked contents are provided "AS IS" by the respective contributors. They do not constitute TI specifications and do not necessarily reflect TI's views; see TI's [Terms of Use](#).

TI E2E™ Online Community *TI's Engineer-to-Engineer (E2E) Community*. Created to foster collaboration among engineers. At e2e.ti.com, you can ask questions, share knowledge, explore ideas and help solve problems with fellow engineers.

Design Support *TI's Design Support* Quickly find helpful E2E forums along with design support tools and contact information for technical support.

11.4 Trademarks

E2E is a trademark of Texas Instruments.
All other trademarks are the property of their respective owners.

11.5 Electrostatic Discharge Caution



This integrated circuit can be damaged by ESD. Texas Instruments recommends that all integrated circuits be handled with appropriate precautions. Failure to observe proper handling and installation procedures can cause damage.

ESD damage can range from subtle performance degradation to complete device failure. Precision integrated circuits may be more susceptible to damage because very small parametric changes could cause the device not to meet its published specifications.

11.6 Glossary

[SLYZ022](#) — *TI Glossary*.

This glossary lists and explains terms, acronyms, and definitions.

12 Mechanical, Packaging, and Orderable Information

The following pages include mechanical, packaging, and orderable information. This information is the most-current data available for the designated device. This data is subject to change without notice and without revision of this document. For browser-based versions of this data sheet, see the left-hand navigation pane.

PACKAGING INFORMATION

Orderable Device	Status (1)	Package Type	Package Drawing	Pins	Package Qty	Eco Plan (2)	Lead/Ball Finish (6)	MSL Peak Temp (3)	Op Temp (°C)	Device Marking (4/5)	Samples
DRV10974PWPR	ACTIVE	HTSSOP	PWP	16	2000	Green (RoHS & no Sb/Br)	CU NIPDAU	Level-3-260C-168 HR	-40 to 125	10974	Samples
DRV10974RUMR	ACTIVE	WQFN	RUM	16	3000	Green (RoHS & no Sb/Br)	CU NIPDAU	Level-2-260C-1 YEAR	-40 to 125	DRV 10974	Samples
XDRV10974RUMR	ACTIVE	WQFN	RUM	16	1	TBD	Call TI	Call TI	-40 to 125		Samples

(1) The marketing status values are defined as follows:

ACTIVE: Product device recommended for new designs.

LIFEBUY: TI has announced that the device will be discontinued, and a lifetime-buy period is in effect.

NRND: Not recommended for new designs. Device is in production to support existing customers, but TI does not recommend using this part in a new design.

PREVIEW: Device has been announced but is not in production. Samples may or may not be available.

OBSELETE: TI has discontinued the production of the device.

(2) **RoHS:** TI defines "RoHS" to mean semiconductor products that are compliant with the current EU RoHS requirements for all 10 RoHS substances, including the requirement that RoHS substance do not exceed 0.1% by weight in homogeneous materials. Where designed to be soldered at high temperatures, "RoHS" products are suitable for use in specified lead-free processes. TI may reference these types of products as "Pb-Free".

RoHS Exempt: TI defines "RoHS Exempt" to mean products that contain lead but are compliant with EU RoHS pursuant to a specific EU RoHS exemption.

Green: TI defines "Green" to mean the content of Chlorine (Cl) and Bromine (Br) based flame retardants meet JS709B low halogen requirements of <=1000ppm threshold. Antimony trioxide based flame retardants must also meet the <=1000ppm threshold requirement.

(3) MSL, Peak Temp. - The Moisture Sensitivity Level rating according to the JEDEC industry standard classifications, and peak solder temperature.

(4) There may be additional marking, which relates to the logo, the lot trace code information, or the environmental category on the device.

(5) Multiple Device Markings will be inside parentheses. Only one Device Marking contained in parentheses and separated by a "~" will appear on a device. If a line is indented then it is a continuation of the previous line and the two combined represent the entire Device Marking for that device.

(6) Lead/Ball Finish - Orderable Devices may have multiple material finish options. Finish options are separated by a vertical ruled line. Lead/Ball Finish values may wrap to two lines if the finish value exceeds the maximum column width.

Important Information and Disclaimer: The information provided on this page represents TI's knowledge and belief as of the date that it is provided. TI bases its knowledge and belief on information provided by third parties, and makes no representation or warranty as to the accuracy of such information. Efforts are underway to better integrate information from third parties. TI has taken and continues to take reasonable steps to provide representative and accurate information but may not have conducted destructive testing or chemical analysis on incoming materials and chemicals. TI and TI suppliers consider certain information to be proprietary, and thus CAS numbers and other limited information may not be available for release.

In no event shall TI's liability arising out of such information exceed the total purchase price of the TI part(s) at issue in this document sold by TI to Customer on an annual basis.

TAPE AND REEL INFORMATION



QUADRANT ASSIGNMENTS FOR PIN 1 ORIENTATION IN TAPE



*All dimensions are nominal

Device	Package Type	Package Drawing	Pins	SPQ	Reel Diameter (mm)	Reel Width W1 (mm)	A0 (mm)	B0 (mm)	K0 (mm)	P1 (mm)	W (mm)	Pin1 Quadrant
DRV10974PWPR	HTSSOP	PWP	16	2000	330.0	12.4	6.9	5.6	1.6	8.0	12.0	Q1
DRV10974RUMR	WQFN	RUM	16	3000	330.0	12.4	4.25	4.25	1.15	8.0	12.0	Q2

TAPE AND REEL BOX DIMENSIONS

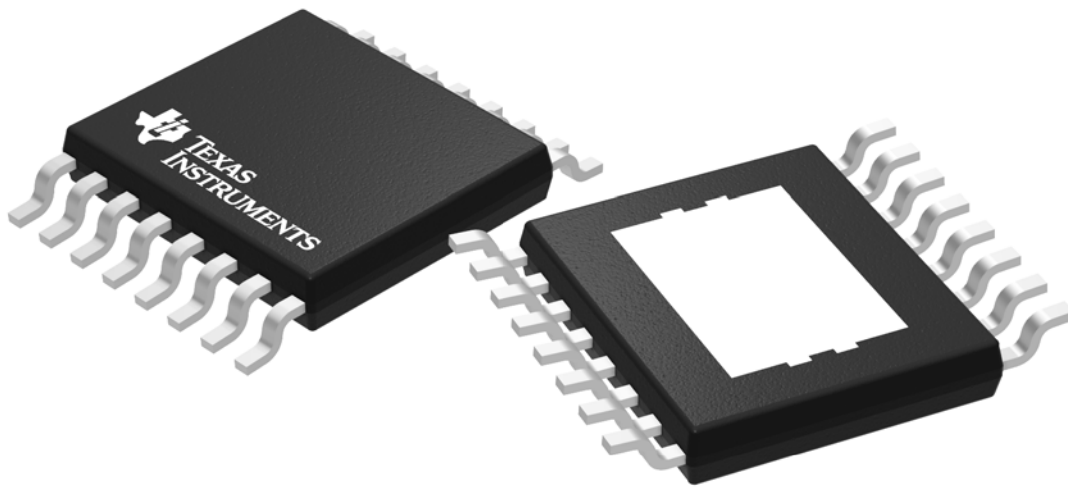

*All dimensions are nominal

Device	Package Type	Package Drawing	Pins	SPQ	Length (mm)	Width (mm)	Height (mm)
DRV10974PWPR	HTSSOP	PWP	16	2000	367.0	367.0	38.0
DRV10974RUMR	WQFN	RUM	16	3000	367.0	367.0	35.0

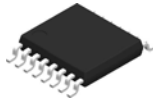

Images above are just a representation of the package family, actual package may vary.
Refer to the product data sheet for package details.

PWP0016J



PACKAGE OUTLINE

PowerPAD™ TSSOP - 1.2 mm max height

SMALL OUTLINE PACKAGE

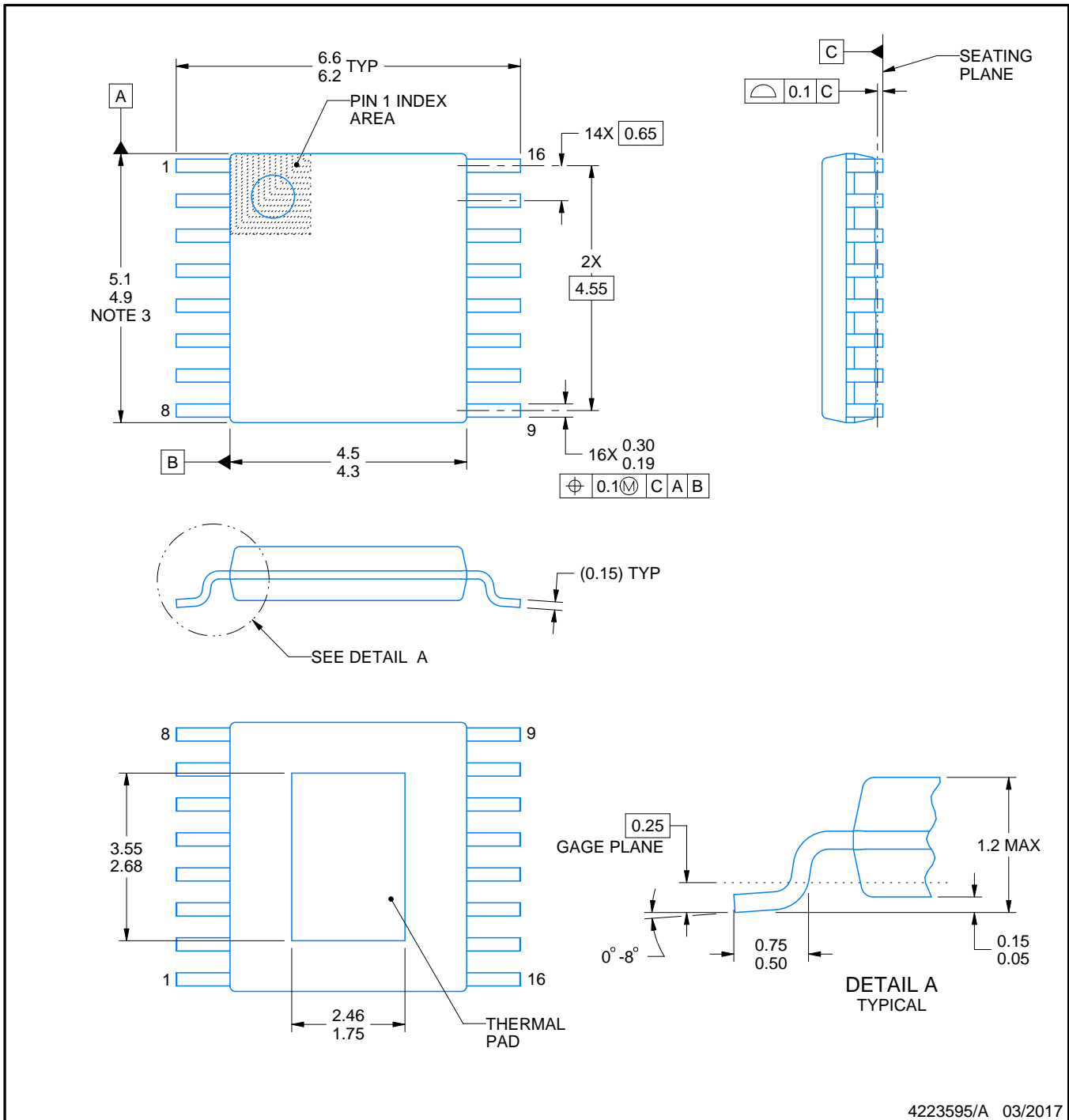

NOTES:

PowerPAD is a trademark of Texas Instruments.

1. All linear dimensions are in millimeters. Any dimensions in parenthesis are for reference only. Dimensioning and tolerancing per ASME Y14.5M.
2. This drawing is subject to change without notice.
3. This dimension does not include mold flash, protrusions, or gate burrs. Mold flash, protrusions, or gate burrs shall not exceed 0.15 mm per side.
4. Reference JEDEC registration MO-153.

EXAMPLE BOARD LAYOUT

PWP0016J

PowerPAD™ TSSOP - 1.2 mm max height

SMALL OUTLINE PACKAGE

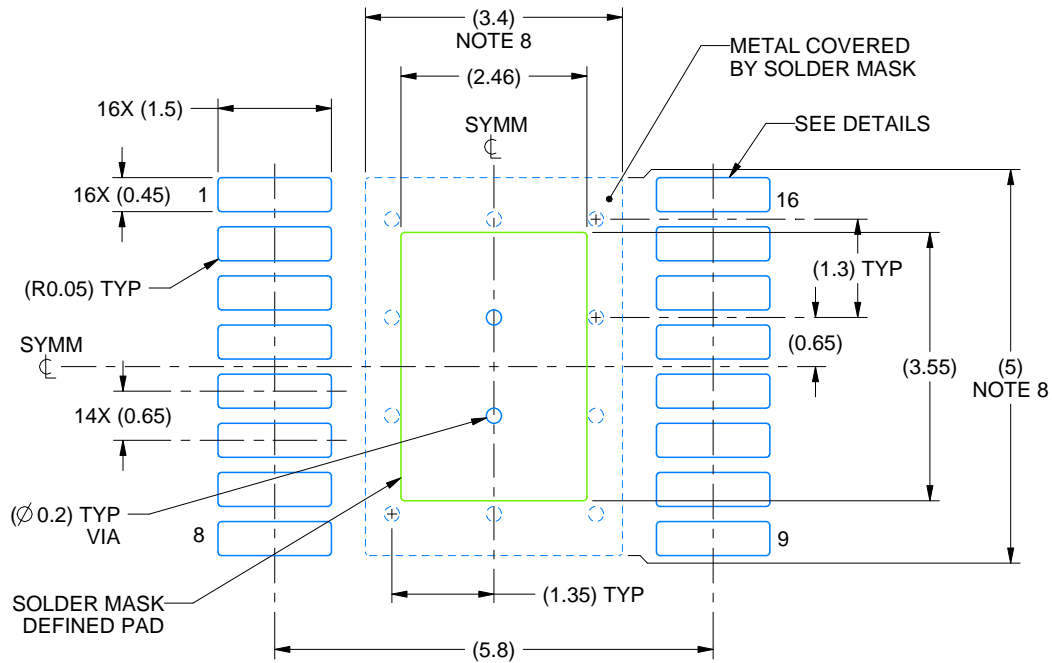

LAND PATTERN EXAMPLE
EXPOSED METAL SHOWN
SCALE: 10X

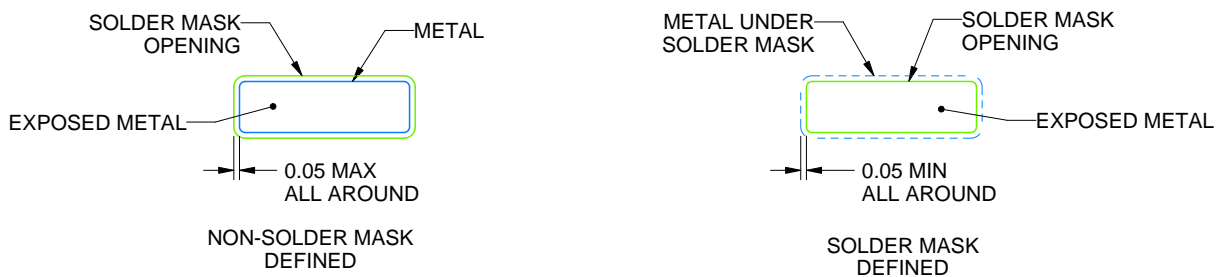

SOLDER MASK DETAILS

4223595/A 03/2017

NOTES: (continued)

5. Publication IPC-7351 may have alternate designs.
6. Solder mask tolerances between and around signal pads can vary based on board fabrication site.
7. This package is designed to be soldered to a thermal pad on the board. For more information, see Texas Instruments literature numbers SLMA002 (www.ti.com/lit/slma002) and SLMA004 (www.ti.com/lit/slma004).
8. Size of metal pad may vary due to creepage requirement.
9. Vias are optional depending on application, refer to device data sheet. It is recommended that vias under paste be filled, plugged or tented.

EXAMPLE STENCIL DESIGN

PWP0016J

PowerPAD™ TSSOP - 1.2 mm max height

SMALL OUTLINE PACKAGE

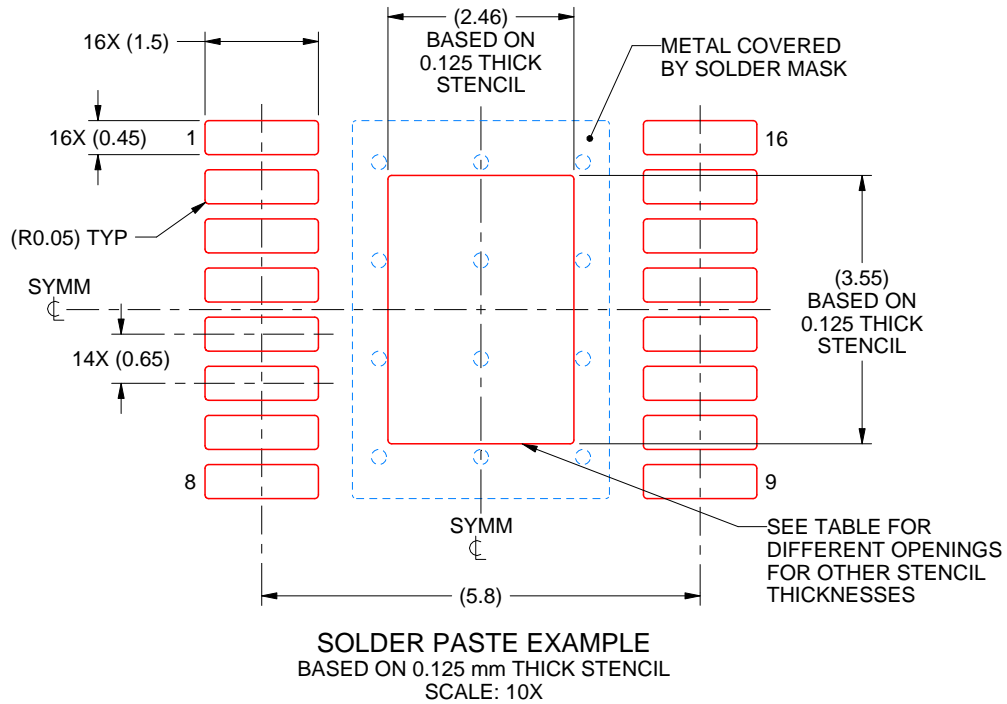

STENCIL THICKNESS	SOLDER STENCIL OPENING
0.1	2.75 X 3.97
0.125	2.46 X 3.55 (SHOWN)
0.15	2.25 X 3.24
0.175	2.08 X 3.00

4223595/A 03/2017

NOTES: (continued)

10. Laser cutting apertures with trapezoidal walls and rounded corners may offer better paste release. IPC-7525 may have alternate design recommendations.
11. Board assembly site may have different recommendations for stencil design.

RUM (S-PQFP-N16)

PLASTIC QUAD FLATPACK

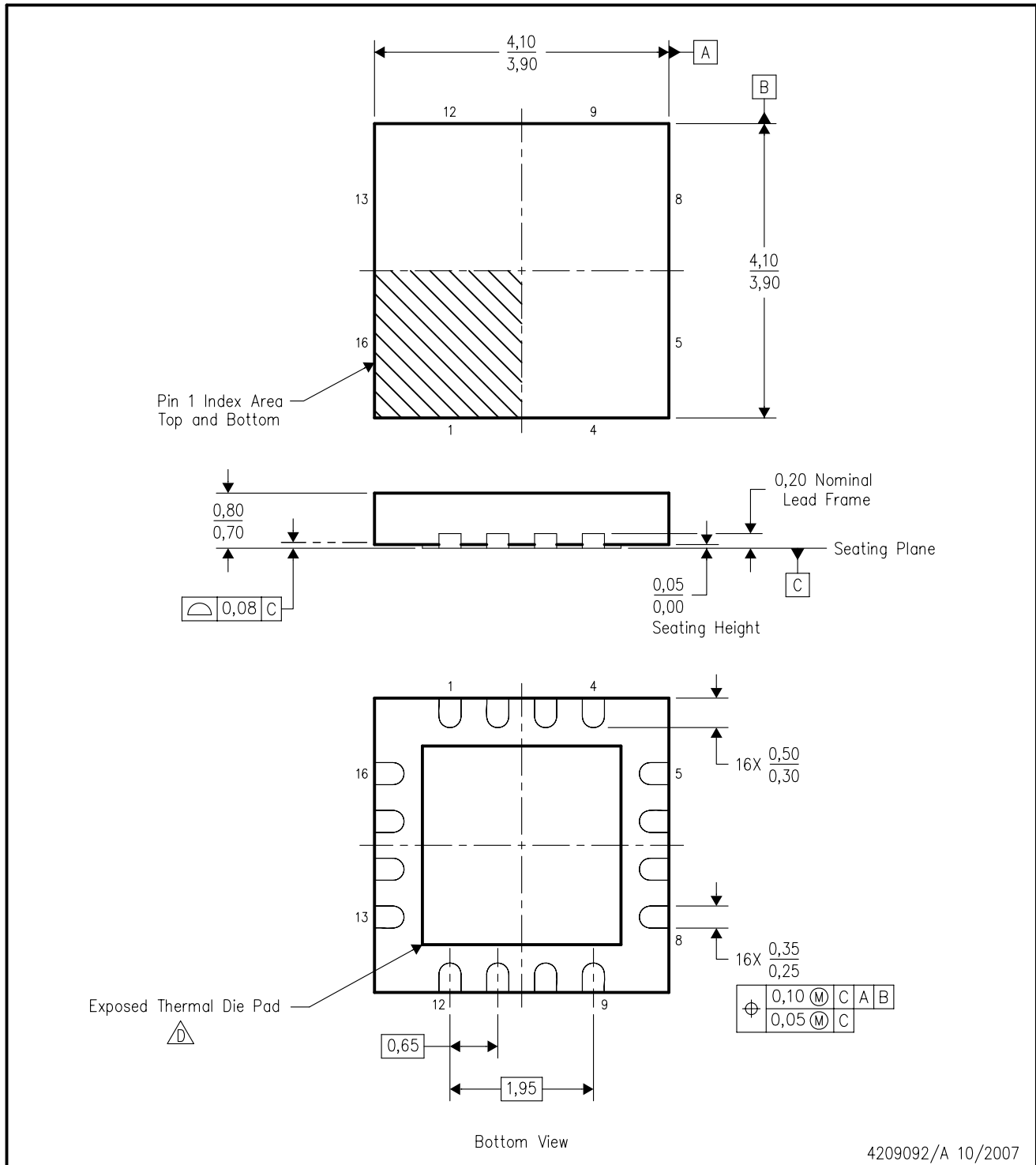

- NOTES:
- A. All linear dimensions are in millimeters. Dimensioning and tolerancing per ASME Y14.5M-1994.
 - B. This drawing is subject to change without notice.
 - C. QFN (Quad Flatpack No-Lead) package configuration.
 - D. The package thermal pad must be soldered to the board for thermal and mechanical performance. See the Product Data Sheet for details regarding the exposed thermal pad dimensions.
 - E. Package complies to JEDEC MO-220 variation WGGC-3.

THERMAL INFORMATION

This package incorporates an exposed thermal pad that is designed to be attached directly to an external heatsink. The thermal pad must be soldered directly to the printed circuit board (PCB). After soldering, the PCB can be used as a heatsink. In addition, through the use of thermal vias, the thermal pad can be attached directly to the appropriate copper plane shown in the electrical schematic for the device, or alternatively, can be attached to a special heatsink structure designed into the PCB. This design optimizes the heat transfer from the integrated circuit (IC).

For information on the Quad Flatpack No-Lead (QFN) package and its advantages, refer to Application Report, QFN/SON PCB Attachment, Texas Instruments Literature No. SLUA271. This document is available at www.ti.com.

The exposed thermal pad dimensions for this package are shown in the following illustration.

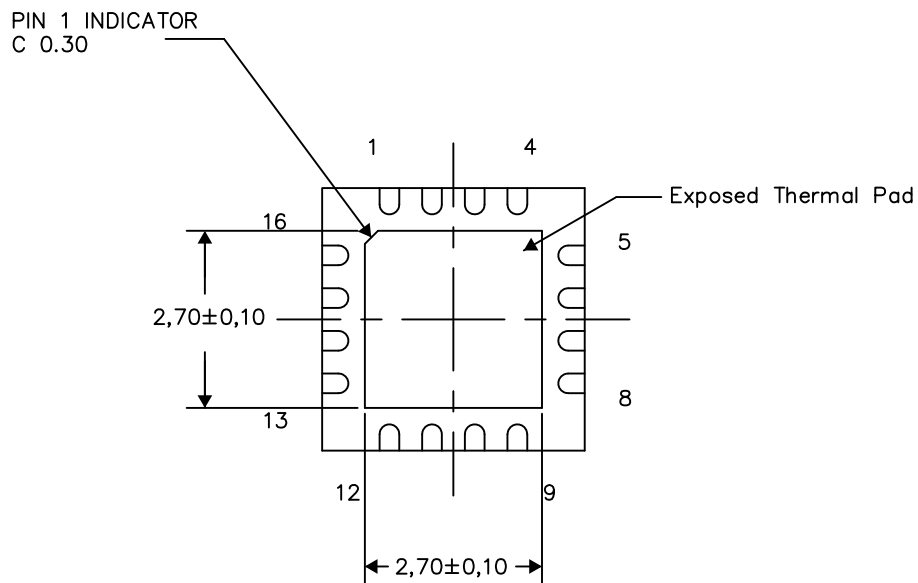

Bottom View

Exposed Thermal Pad Dimensions

4209093-2/F 09/15

NOTES: All linear dimensions are in millimeters

RUM (S-PWQFN-N16)

PLASTIC QUAD FLATPACK NO-LEAD

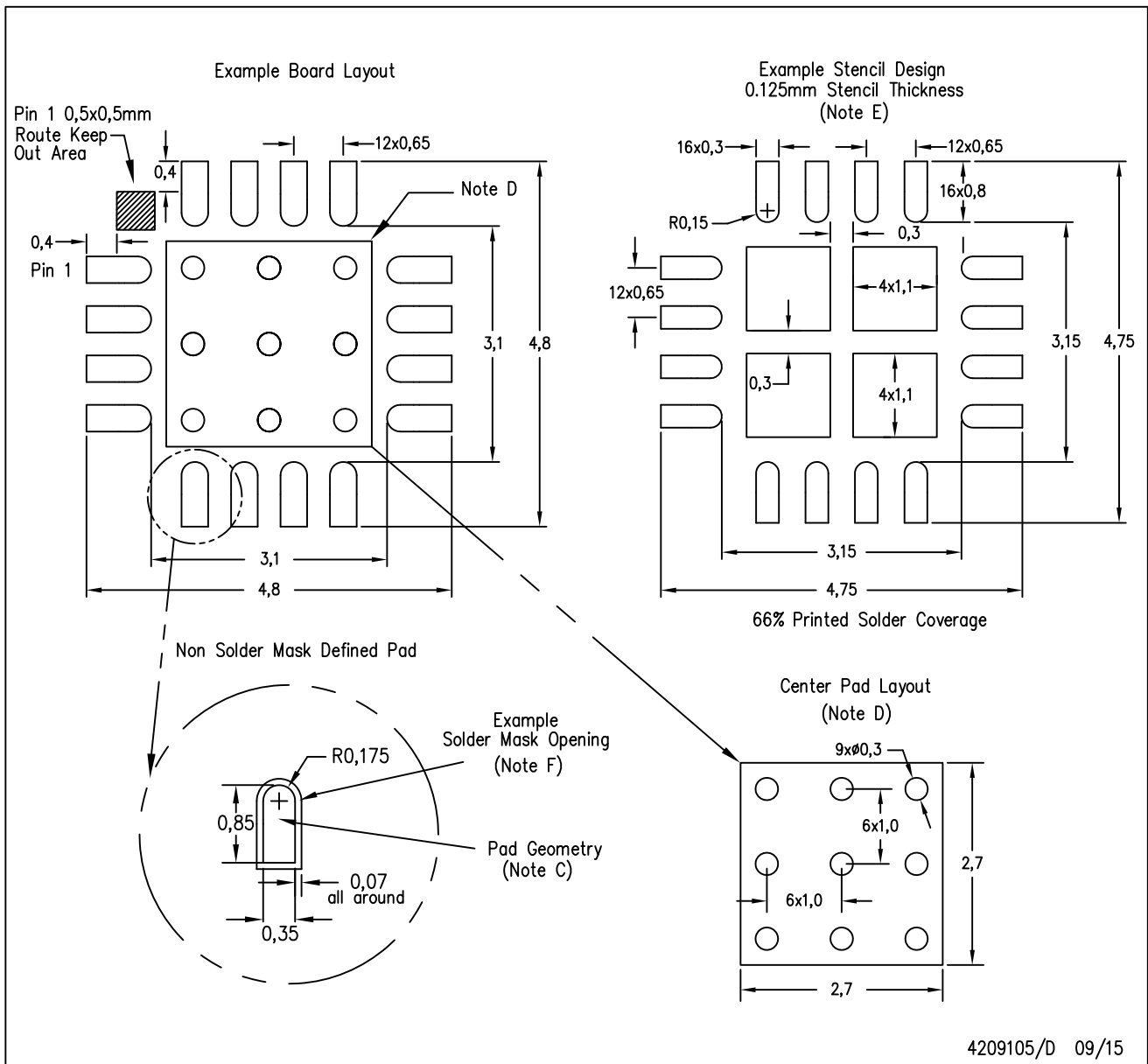

- NOTES:
- All linear dimensions are in millimeters.
 - This drawing is subject to change without notice.
 - Publication IPC-7351 is recommended for alternate designs.
 - This package is designed to be soldered to a thermal pad on the board. Refer to Application Note, QFN Packages, Texas Instruments Literature No. SLUA271, and also the Product Data Sheets for specific thermal information, via requirements, and recommended board layout. These documents are available at www.ti.com <<http://www.ti.com>>.
 - Laser cutting apertures with trapezoidal walls and also rounding corners will offer better paste release. Customers should contact their board assembly site for stencil design recommendations. Refer to IPC 7525 for stencil design considerations.
 - Customers should contact their board fabrication site for solder mask tolerances.

IMPORTANT NOTICE AND DISCLAIMER

TI PROVIDES TECHNICAL AND RELIABILITY DATA (INCLUDING DATASHEETS), DESIGN RESOURCES (INCLUDING REFERENCE DESIGNS), APPLICATION OR OTHER DESIGN ADVICE, WEB TOOLS, SAFETY INFORMATION, AND OTHER RESOURCES "AS IS" AND WITH ALL FAULTS, AND DISCLAIMS ALL WARRANTIES, EXPRESS AND IMPLIED, INCLUDING WITHOUT LIMITATION ANY IMPLIED WARRANTIES OF MERCHANTABILITY, FITNESS FOR A PARTICULAR PURPOSE OR NON-INFRINGEMENT OF THIRD PARTY INTELLECTUAL PROPERTY RIGHTS.

These resources are intended for skilled developers designing with TI products. You are solely responsible for (1) selecting the appropriate TI products for your application, (2) designing, validating and testing your application, and (3) ensuring your application meets applicable standards, and any other safety, security, or other requirements. These resources are subject to change without notice. TI grants you permission to use these resources only for development of an application that uses the TI products described in the resource. Other reproduction and display of these resources is prohibited. No license is granted to any other TI intellectual property right or to any third party intellectual property right. TI disclaims responsibility for, and you will fully indemnify TI and its representatives against, any claims, damages, costs, losses, and liabilities arising out of your use of these resources.

TI's products are provided subject to TI's Terms of Sale (www.ti.com/legal/termsofsale.html) or other applicable terms available either on ti.com or provided in conjunction with such TI products. TI's provision of these resources does not expand or otherwise alter TI's applicable warranties or warranty disclaimers for TI products.

Mailing Address: Texas Instruments, Post Office Box 655303, Dallas, Texas 75265
Copyright © 2018, Texas Instruments Incorporated