

Rev	AWO #	Description	Date	Appr
-		RELEASED	6/17/10	

APPROVED: _____
 DATE: _____ TITLE: _____

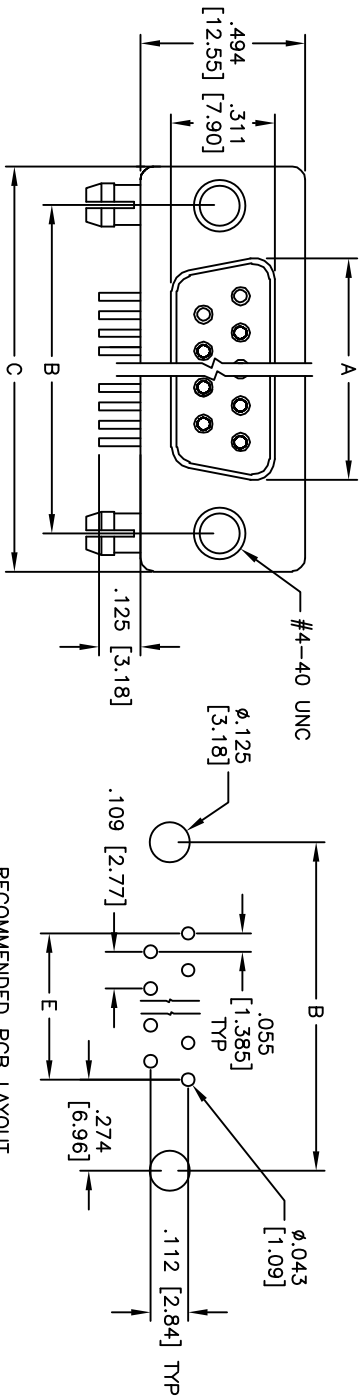

RECOMMENDED PCB LAYOUT

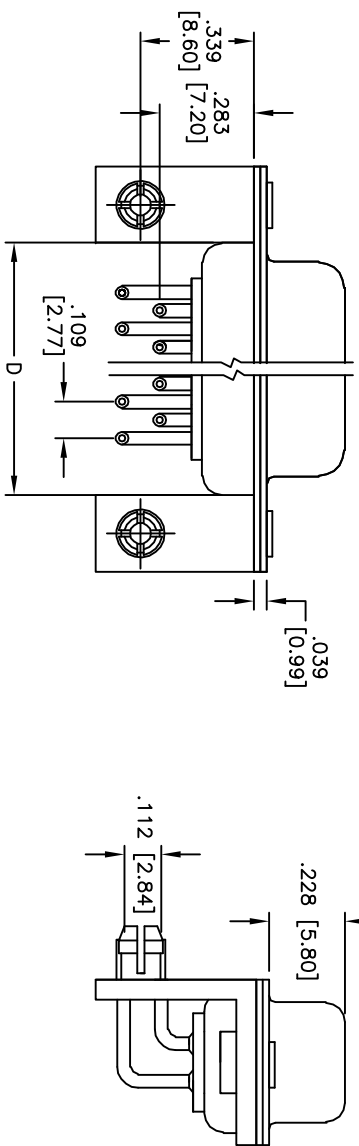

DXXX	NO. OF CONTACTS	DIMENSIONS				
		A	B	C	D	E
DE09	9	.643 [16.33]	.984 [24.99]	1.213 [30.81]	.759 [19.28]	.436 [11.08]
DA15	15	.971 [24.66]	1.312 [33.32]	1.541 [39.14]	1.083 [27.51]	.763 [19.39]
DB25	25	1.511 [38.38]	1.852 [47.04]	2.088 [53.04]	1.625 [41.28]	1.309 [33.24]
DC37	37	2.159 [54.84]	2.500 [63.50]	2.729 [69.32]	2.272 [57.71]	1.963 [49.86]

ADAM TECH

909 Rahway Avenue, Union, NJ 07083
 Phone: 908-687-5000 Fax: 908-687-5710

TITLE: .283 [7.20] FOOTPRINT R/A D-SUB SOCKET
 METAL BRACKETS W/4-40 THREADED INSERTS

SIZE	PART NO.	REV.
X	DXXX-SH-C2AM	-

SPECIFICATIONS:
 Material: PBT, glass reinforced, rated UL 94V-0
 Insulator color: Black
 Contacts: Phosphor Bronze
 Shell: Steel, Tin plated
 Hardware: Brass, Nickel plated
 Plating: Gold flash over Nickel underplate overall
 Electrical:
 Contact resistance: 10 mohms max
 Insulation resistance: 5,000 Mohms min
 Dielectric withstanding voltage: 1,000 VAC for 1 minute
 Temperature Rating: Operating temperature: -55°C to +125°C
 Environmental:
 Lead free, RoHS compliant
 Recommended soldering temp: 235°C for 5 seconds

