

ECS...

Electronic enclosures

Data sheet
3778_en_A

© PHOENIX CONTACT 2018-04-26



1 Description

The Environmental Case System (ECS) is an enclosure system to protect devices from the elements in outdoor or indoor applications. The ECS... product line consists of a base and faceplate that are combined to make a complete enclosure system.

The enclosure is available in two different locking methods: screw and mechanical latch. Both locking methods are available with or without a breather vent to alleviate pressure buildup when the enclosure is sealed and reduce condensation formation.

Faceplates are available with a variety of connectors to meet various application requirements. A blank faceplate is available that can be customized to meet virtually any connector configuration.

Wall, machine, and pole-mounting options allow flexibility for different applications.



3D housing data can be found at phoenixcontact.net/products.



Make sure you always use the latest documentation. It can be downloaded at phoenixcontact.net/products.



This document is valid for all products listed in the "Ordering data" on page 4

Table of contents

1	Description.....	1
2	Overview of the ECS... products	3
3	Ordering data.....	4
4	Technical data	4
5	Dimensions.....	5
5.1	External	5
5.2	Internal	6
5.3	PCB dimensions.....	7
6	Connection technology	8
6.1	ECS-P...B faceplate	8
6.2	ECS-P...M12 faceplate.....	8
6.3	ECS-P...CG faceplate	9
7	Installation	9
7.1	Printed circuit board to faceplate assembly.....	9
7.2	Board lock (optional)	9
7.3	Faceplate and base.....	10
7.4	Mounting	11

2 Overview of the ECS... products

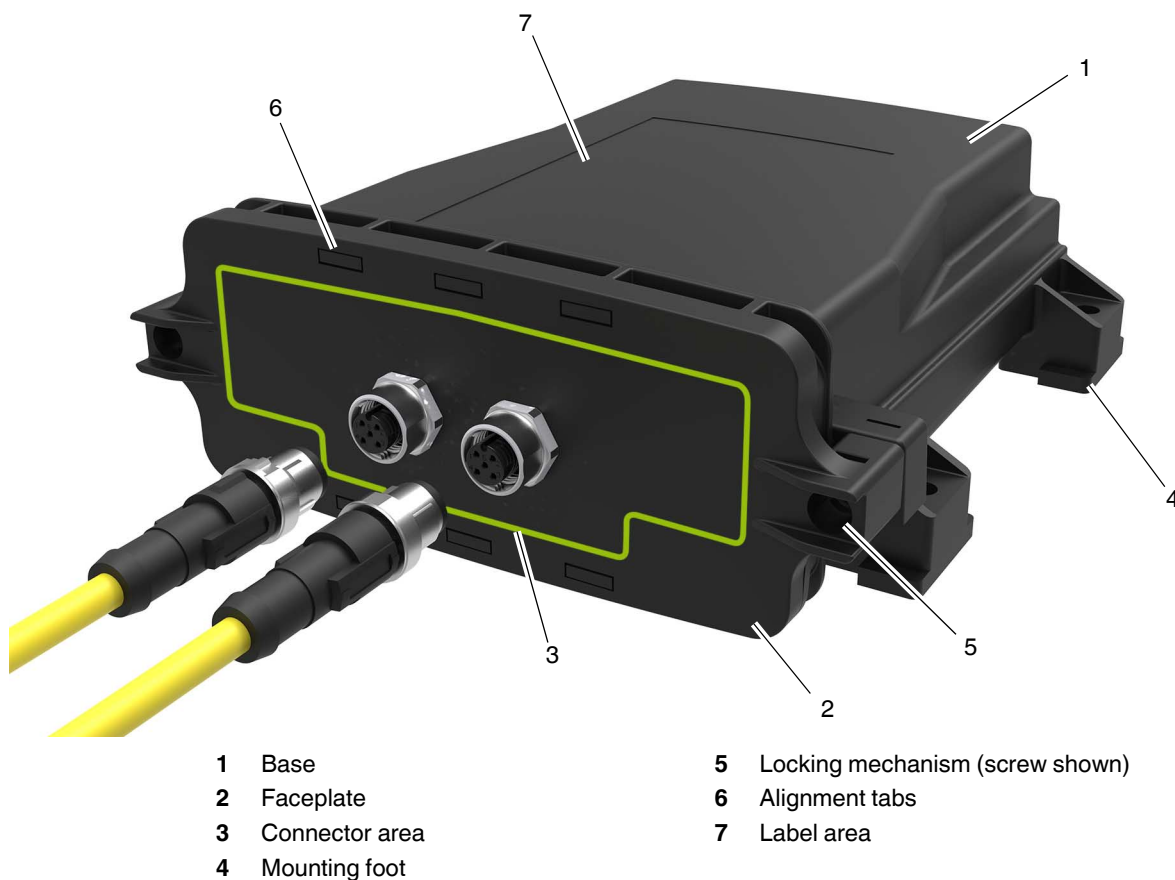

Figure 1 Typical ECS... assembly (screw latch shown)

The faceplate is available as a blank, with one or two M12 connectors, or a cable gland.

The ECS... system provides two locking methods to secure the faceplate to the base.

- Mechanical latch: No tools are required to secure the faceplate to the base, but a flat blade screwdriver is required to release the faceplate for removal.
- Screw latch: Faceplate is secured to the base using screws that accept either a flat screwdriver or T20 Torx[®] driver.

3 Ordering data

Products

Description	Type	Order No.	Pcs./Pkt.
Base, mechanical latch, vented, black	ECS-B-122X169-L-UV1-V	2230000	5
Base, mechanical latch, non-vented, black	ECS-B-122X169-L-UV1-NV	2230001	5
Base, screw latch, vented, black	ECS-B-122X169-S-UV1-V	2230002	5
Base, screw latch, non-vented, black	ECS-B-122X169-S-UV1-NV	2230003	5
Faceplate, mechanical latch, blank, black	ECS-P-122X169-L-UV1-B	2230004	5
Faceplate, mechanical latch, one M12 connector, black	ECS-P-122X169-L-UV1-1M12	2230005	5
Faceplate, mechanical latch, two M12 connectors, black	ECS-P-122X169-L-UV1-2M12	2230006	5
Faceplate, mechanical latch, one cable gland, black	ECS-P-122X169-L-UV1-CG	2230007	5
Faceplate, screw latch, blank, black	ECS-P-122X169-S-UV1-B	2230008	5
Faceplate, screw latch, one M12 connector, black	ECS-P-122X169-S-UV1-1M12	2230009	5
Faceplate, screw latch, two M12 connectors, black	ECS-P-122X169-S-UV1-2M12	2230010	5
Faceplate, screw latch, one cable gland, black	ECS-P-122X169-S-UV1-CG	2230011	5
Base, mechanical latch, vented, gray	ECS-B-122X169-L-UV-V GY	1050206	5
Base, mechanical latch, non-vented, gray	ECS-B-122X169-L-UV-NV GY	1050212	5
Base, screw latch, vented, gray	ECS-B-122X169-S-UV-V GY	1050209	5
Base, screw latch, non-vented, gray	ECS-B-122X169-S-UV-NV GY	1050207	5
Faceplate, mechanical latch, blank, gray	ECS-P-122X169-L-UV-B GY	1050386	5
Faceplate, mechanical latch, one M12 connector, gray	ECS-P-122X169-L-UV-1M12 GY	1050385	5
Faceplate, mechanical latch, two M12 connectors, gray	ECS-P-122X169-L-UV-2M12 GY	1050384	5
Faceplate, mechanical latch, one cable gland, gray	ECS-P-122X169-L-UV-CG GY	1050383	5
Faceplate, screw latch, blank, gray	ECS-P-122X169-S-UV-B GY	1050382	5
Faceplate, screw latch, one M12 connector, gray	ECS-P-122X169-S-UV-1M12 GY	1050381	5
Faceplate, screw latch, two M12 connectors, gray	ECS-P-122X169-S-UV-2M12 GY	1050379	5
Faceplate, screw latch, one cable gland, gray	ECS-P-122X169-S-UV-CG GY	1050380	5

Accessories

Description	Type	Order No.	Pcs./Pkt.
Board lock	ECS-BL	2230012	10
Pole-mounting kit	ECS-PM	2230013	1

4 Technical data

General data

Ambient temperature, operating	-40...85°C
Ambient temperature, storage	-40...85°C
UL 94 flammability rating	V0
Material	Polycarbonate
Color	Black
Power dissipation, P _v , at 20°C (horizontal mounting position)	19 W
Degree of protection	IP66/67/69
NEMA 250 enclosure rating	6

Conformance

UL 736C (Outdoor suitability)	f1
UL 50/50E	
UL enclosure type ¹	4, 4X, 6
IEC 60068 (Vibration)	15g: 10-2000-10 Hz X, Y, Z for 2.5 h
IEC 60068 (Shock)	50g, 20 pulses
EN 50102 (Impact)	IK08
IEC 60068 (Salt fog)	96 h

¹ Enclosure components must be sold as a kit to apply mark. Contact local sales office for information.

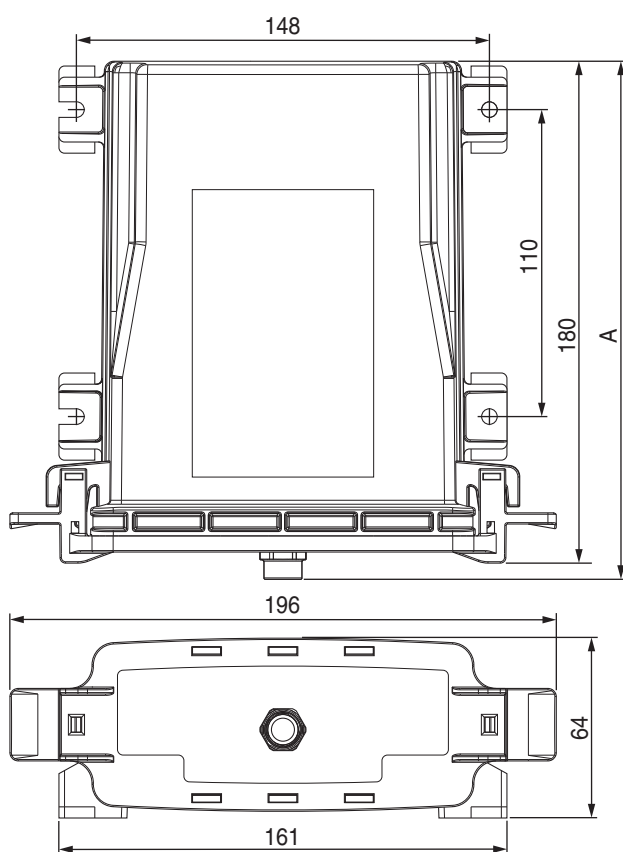
5 Dimensions**5.1 External**

Model	Dimension "A"
ECS-P-...-L-...1M12 (GY)	186 mm
ECS-P-...-L-...2M12 (GY)	186 mm
ECS-P-...-L-...CG (GY)	206 mm
ECS-P-...-L-...B (GY)	176 mm

Figure 2 ECS...L... dimensions

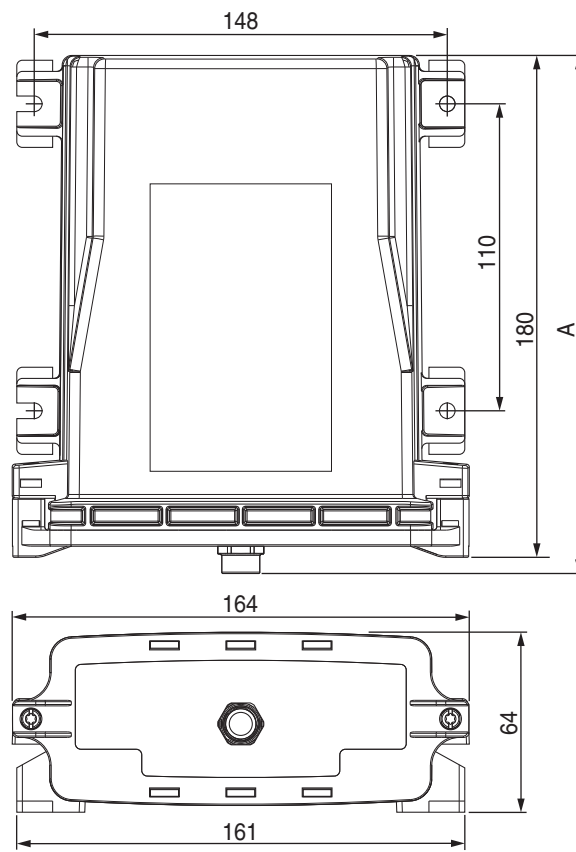

Model	Dimension "A"
ECS-P-...-S-...1M12 (GY)	186 mm
ECS-P-...-S-...2M12 (GY)	186 mm
ECS-P-...-S-...CG (GY)	206 mm
ECS-P-...-L-...B (GY)	176 mm

Figure 3 ECS...S... dimensions

5.2 Internal

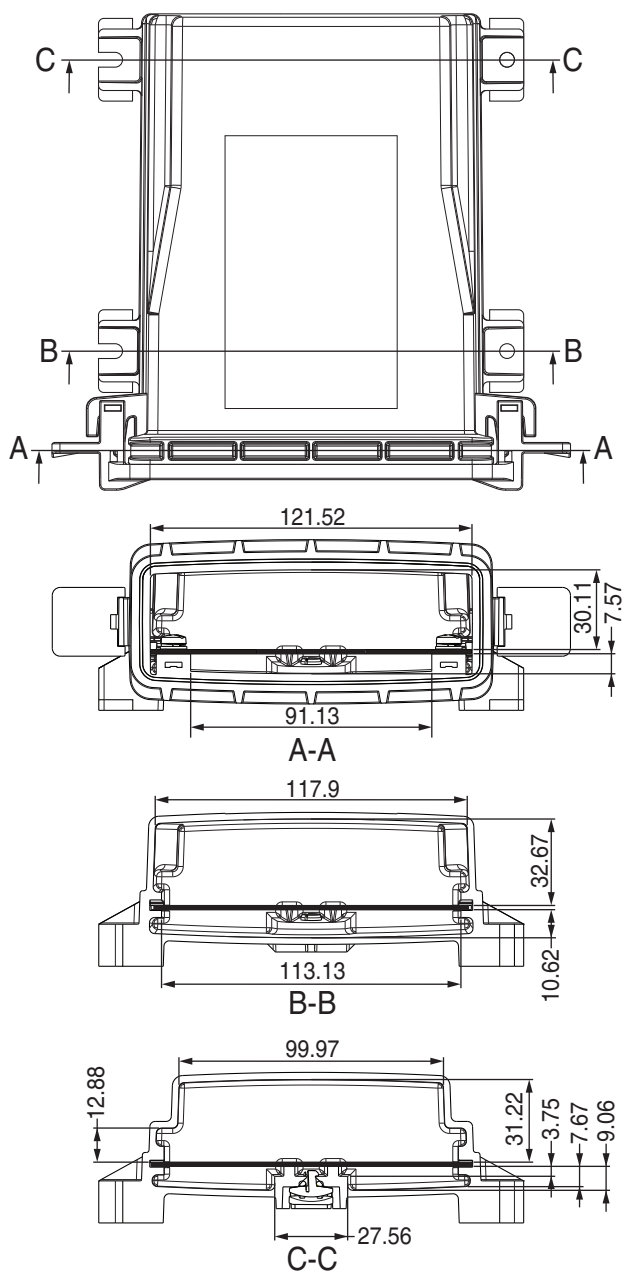

Figure 4 Inside view of enclosure 1.59 mm board

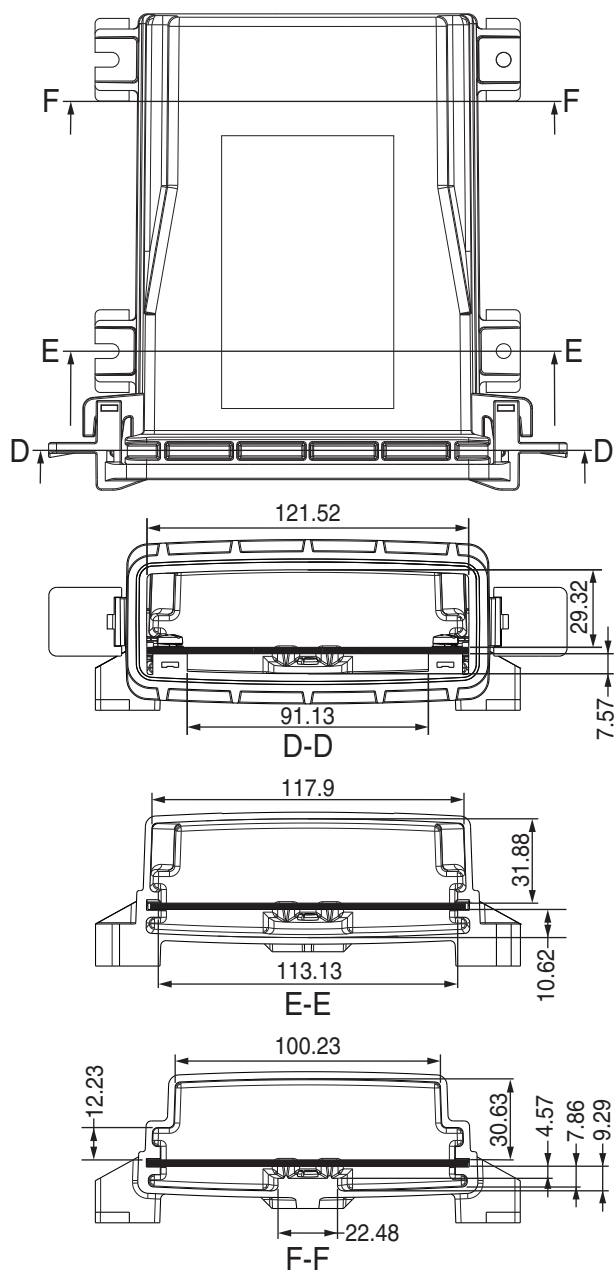

Figure 5 Inside view of enclosure 2.36 mm board

5.3 PCB dimensions

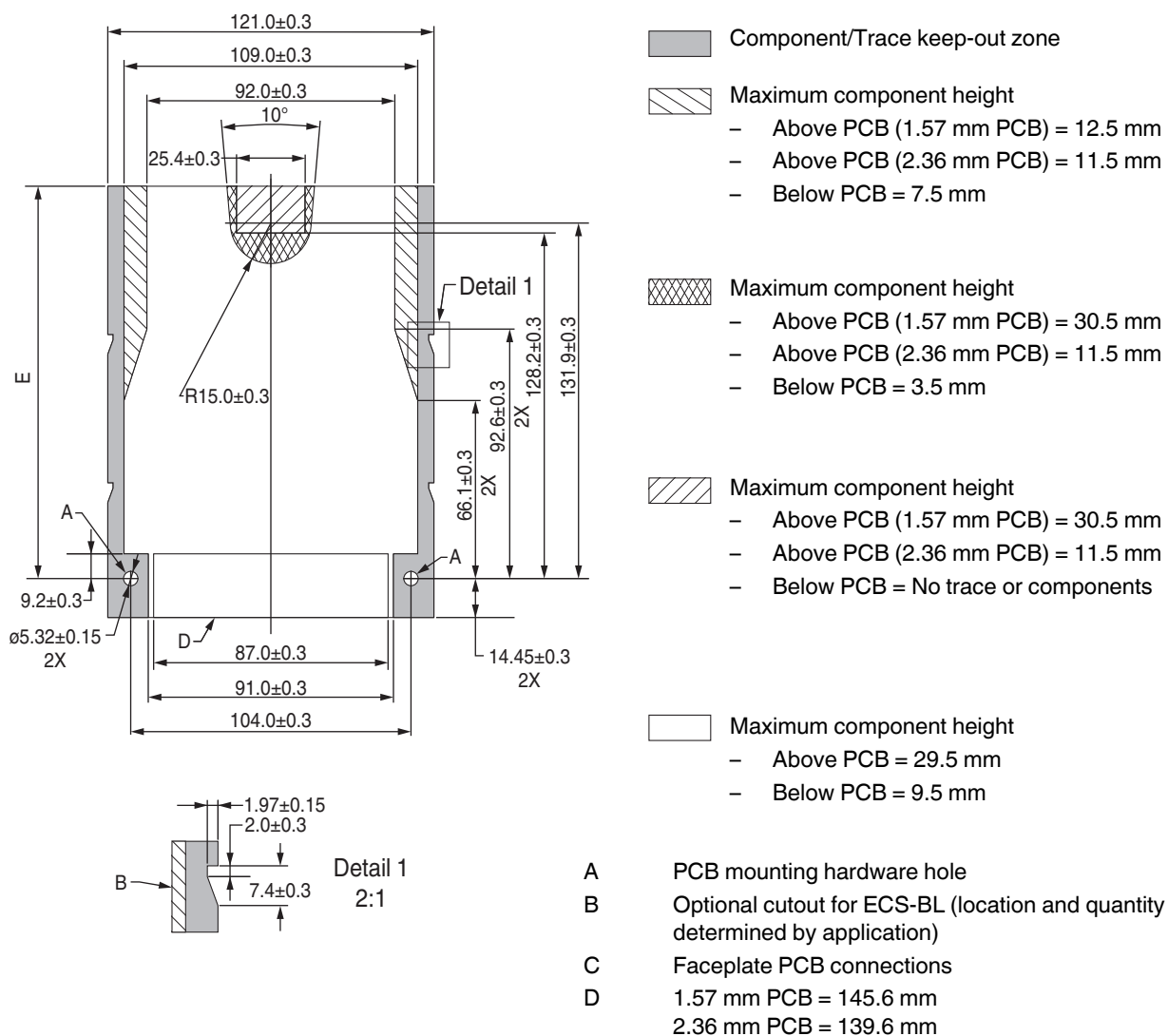

Figure 6 Circuit board design dimensions and restrictions

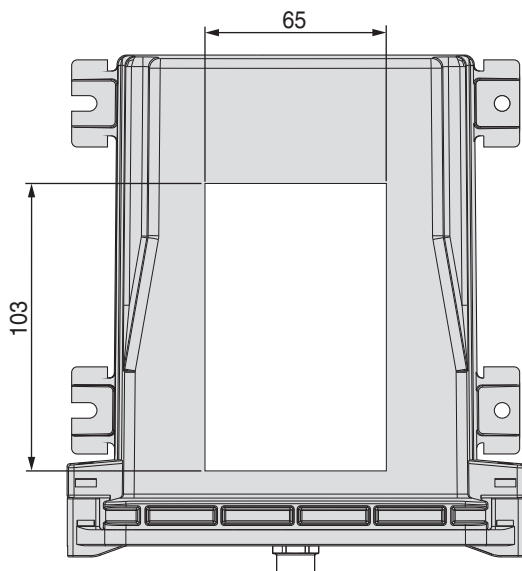

Figure 7 Label area

6 Connection technology

The ECS... enclosure provides for the use of any existing IP66/67 connection technology.

6.1 ECS-P...B faceplate

The ECS-P...B faceplate is provided as a blank faceplate. It allows users to customize the faceplate to meet specific application requirements.

- Add connector styles not currently available as a preconfigured faceplates from Phoenix Contact.
- Combine connector styles for a specific application. For instance, combine two M12 connectors and one RJ45 connector.

The ECS-P...B faceplate allows placement of connectors as desired within a certain area on the faceplate. The placement and number of connectors that can be added to the ECS-P...B (GY) is limited to within the area defined in Figure 8.

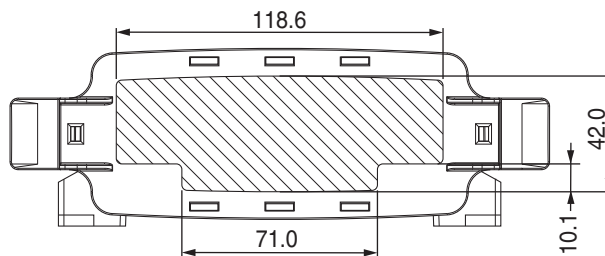

Figure 8 Available connector area for ECS-P...B

The available connector area is the same for both the mechanical latch and screw-type faceplates.

6.2 ECS-P...M12 faceplate

ECS-P...M12 faceplates provide either one or two M12 connectors. The M12 connector is a two-piece system with a nut and insert. An M12 female coupling nut (Order No. 1552243) is provided for installation during assembly.

Designers must order inserts separately for each specific application. Some of the common inserts are:

1432444	SACC-CI-M12FS-4CON-L 90 SH SCO
1436628	SACC-CI-M12FS-4CON-L90 SCO
1432457	SACC-CI-M12FSD-4CON-L90 SCO
1432431	SACC-CI-FS-5CON-L 90 SH SCO
1436644	SACC-CI-M12FS-5CON-L90 SCO
1437009	SACC-CI-M12FS-8CON-L90 SH SCO
1436990	SACC-CI-M12FS-8CON-L90 SCO
1424199	SACC-CI-M12FS-12CON-L90 SH
1424195	SACC-CI-M12FS-12CON-L90
1424201	SACC-CI-M12FS-17CON-L90 SH
1424197	SACC-CI-M12FS-17CON-L90
1424193	SACC-CI-M12FSY-8CON-L90
1424180	SACC-CI-M12FSX-8CON-L90

Installation

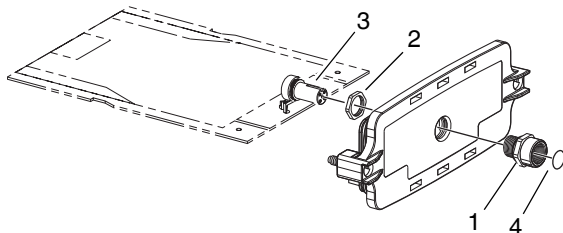

Figure 9 M12 connector installation

1. Position the connector housing (1) into the hole on the ECS-P...M12.
2. Thread the nut (2) on the opposite side and torque to 1.5 to 2.0 Nm.
3. Place the circuit board with the connector insert (3) into position on the ECS-P...M12 with the insert in the center of the connector housing. Secure the circuit board to the ECS-P...M12 (see 7.1 "Printed circuit board to faceplate assembly").



NOTE:

Avoid all radial forces between the connector inserts attached to the circuit board and any connector housings in the faceplate. Axial forces ≤ 80 Nm are acceptable.

4. Once the circuit board is secured to the faceplate, place the o-ring (4) inside the connector housing and over the connector insert. Slide the o-ring to the base of the insert. Use a small tool, if necessary.

6.3 ECS-P...CG faceplate

ECS-P...CG faceplates provide a cable gland to allow a cable to pass directly into the enclosure and connect to the circuit board using one of Phoenix Contact's PCB connectors.



Use webcode #391 at [PhoenixContact.com](https://www.phoenixcontact.com) to review the available PCB terminal blocks.

Use webcode #425 at [PhoenixContact.com](https://www.phoenixcontact.com) to review the available PCB connectors.

Installation

The ECS-P...CG faceplate comes fully assembled. It accepts external cable diameters of 6 to 12 mm.



Search for 1411133 at [PhoenixContact.com](https://www.phoenixcontact.com) for additional details regarding the cable gland.

7 Installation

7.1 Printed circuit board to faceplate assembly

The printed circuit board must be secured to the faceplate before the faceplate is mated to the base.



For ECS-P...M12 faceplates, the M12 connector(s) must be installed on the faceplate prior to attaching the printed circuit board.

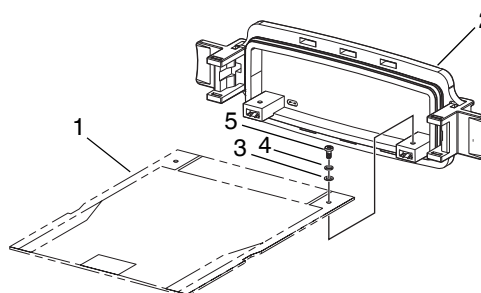

Figure 10 Circuit board placement

1. Place the circuit board (1) in position on the rear of the ECS-P... (2) and secure it with the flat washer (3) lockwasher (4) and screw (5) on both sides of the printed circuit board.
2. Torque the screws to 0.8 Nm.

7.2 Board lock (optional)

An optional board lock may be installed inside the base. The board lock prevents the printed circuit board and faceplate assembly from fully sliding out until the lock is released. This helps prevent a PCB assembly from dropping out of the base during disassembly.



The printed circuit board design must include a notch for the board lock to function. Without the notch, the board lock is ineffective.

Board locks may be installed on one or both sides.

1. Orient the board lock (1) so the side with the lance is on the outside as shown.

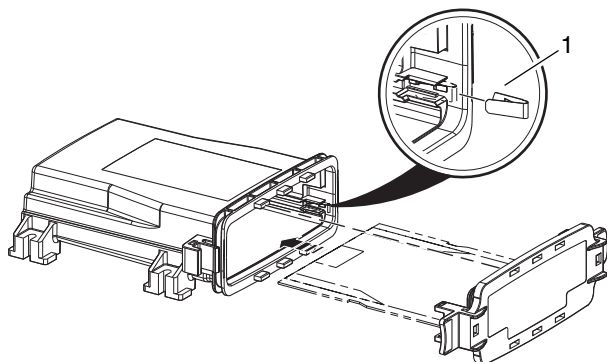

Figure 11 Board lock

2. Align the board lock with the slot in the base.
3. Slide the board lock into the slot until a click is heard.
4. If board locks are desired for both sides, repeat the process for the other side.

7.3 Faceplate and base

7.3.1 Assembly

1. Align the printed circuit board with the slots in the enclosure (ECS-B...).
2. Gently slide the printed circuit board and ECS-P... assembly (2) into the enclosure (ECS-B...).

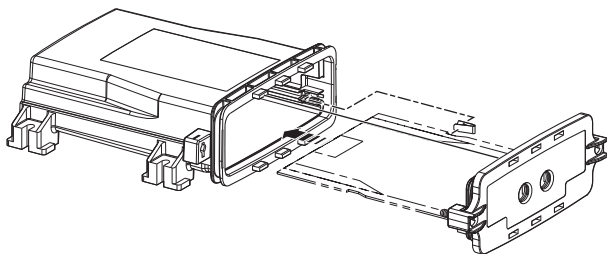

3. There are six tabs on the enclosure face (3) (ECS-B...). The tabs must engage the six slots in the ECS-P... (4) to ensure a proper seal.
4. Secure the faceplate (ECS-P...) to the enclosure (ECS-B...).
 - a) **ECS-P...-L...**: Press the faceplate (ECS-P...) to the enclosure (ECS-B...) until the two latches on the side are secure.
 - b) **ECS-P...-S...**: Torque the two screws to 0.8 Nm using either a T20 Torx bit or blade-style screwdriver.

7.3.2 Disassembly

ECS-P...L...

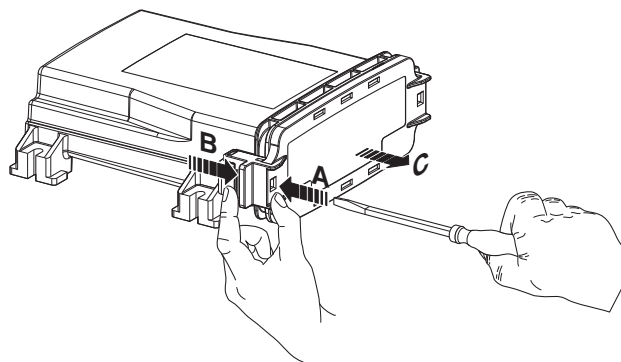

Figure 12 Opening the ECS-P...L...

1. Insert a flat-blade screwdriver (maximum shaft diameter of 3.5 mm) straight into the square hole in the ECS-P... (A). Do not pry!
2. Using only a finger, pull on the tab on the screwdriver side of the ECS-P... until the latch releases slightly (B).
3. Insert the screwdriver into the other side of the ECS-P... and pull up on the tab until the latch releases.
4. With both latches released, pull the ECS-P... and printed circuit board assembly straight from the base (C).

7.3.3 ECS-P...S...

1. Using a screwdriver or T20 Torx driver, turn the screws securing the ECS-P...-S... counterclockwise until the screw disengages from the threads on the ECS-B....
2. Pull the ECS-P... and PCB assembly straight from the base.

7.3.4 With optional board lock

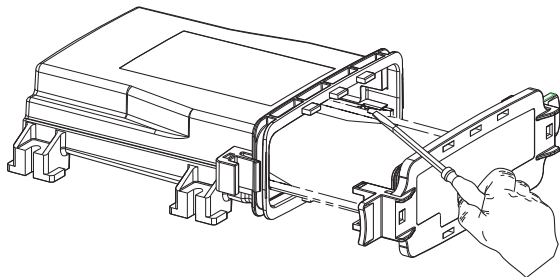

Figure 13 Board lock release

If the optional ECS-BL is installed, follow the normal opening procedures. When the ECS-BL engages the notches in the printed circuit board and halts removal, insert a small tool to hold the lock open before continuing to remove the assembly.

7.4 Mounting

The ECS... may be mounted directly to a wall or mounted to a pole using the optional ECS-PM pole mount kit (Order No. 2230013).

7.4.1 Direct mounting

When direct mounting the ECS..., the integrated mounting feet are used. The base accepts mounting hardware up to 5 mm diameter.



Mounting hardware is not included and must be obtained locally. Select hardware that is appropriate for the mounting surface.

Use the base as a template or refer to Figure 2 and Figure 3.

7.4.2 Pole mounting

The ECS... may be mounted to a round or square pole with a pole diameter of 5 to 15 cm using the ECS-PM pole mounting kit. This kit allows attachment to a pole using either hose clamps or bolts.



Hardware and hose clamps, if required, must be purchased locally for the application mounting surface. The maximum hose clamp width is 13 mm).

The ECS-PM is comprised of two part A and two part B components. Each part A joins with a part B and slides onto the mounting feet of the base.

Attachment to the base

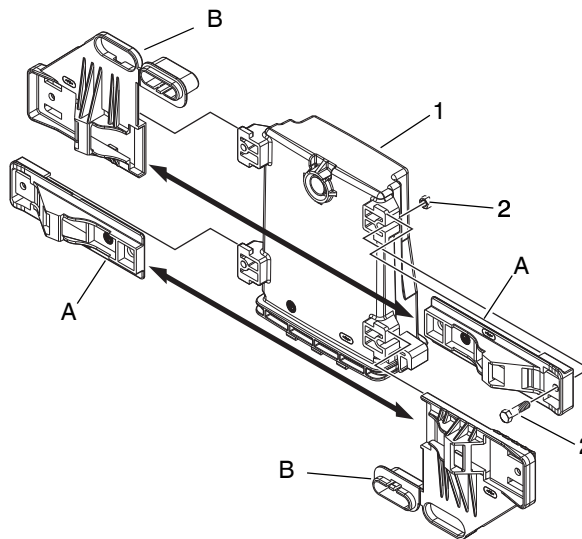

Figure 14 ECS-PM assembly

1. Take part A and partially slide it onto one mounting foot of the housing (1).
2. Take part B and partially slide in onto the opposite mounting foot of the housing.
3. Part A and part B will intersect. Slide each part together until they are fully engaged and come against the stop on the mounting feet.
4. Repeat steps 1 though 3 for the second pair of parts A and B.
5. If the assembly is to be mounted using bolts through the standoffs, secure the part A and B pairs to the housing using M5 (3/16-in.) hardware (2) in four places.

Hose-clamp mounting



The integrated standoff can be removed when using the hose-clamp mounting method.

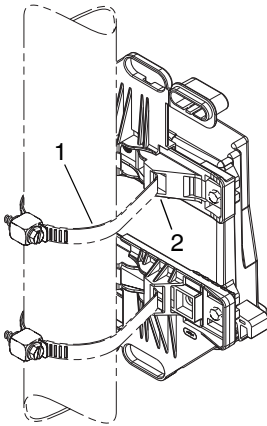

Figure 15 Hose-clamp mounting

1. Open the hose clamp (1) and insert it in the opening (2) of the part A and B assembly attached to the enclosure.
2. Repeat step 1 for the second hose clamp.
3. Place the open hose clamps around the pole. Close the hose clamp and tighten per manufacturer's instructions.

Bolt mounting



The appropriate hardware type (wood, metal, self-tapping, etc.) for the mounting surface must be purchased locally. The maximum hardware diameter is 10 mm.

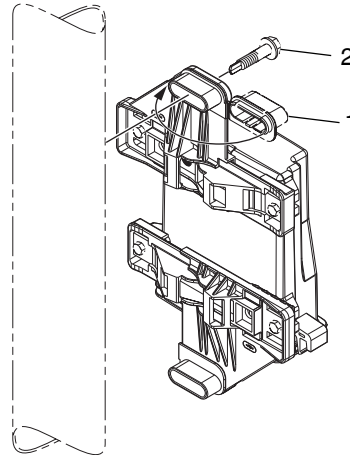

Figure 16 Bolt mounting

1. Fold the integrated standoffs (1), upper and lower, 180° into position in the center of the assembly and snap them into place to secure.
2. Insert the mounting hardware (2) through the brackets and standoffs, and secure the assembly to the mounting surface.
3. Torque the mounting hardware as specified by the manufacturer.