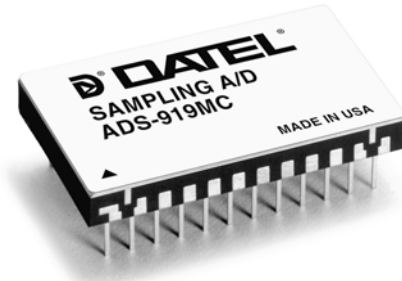


**FEATURES**

- 14-bit resolution
- 2MHz sampling rate
- No missing codes
- Functionally complete
- Small 24-pin DDIP or SMT package
- Low power, 1.8 Watts
- Operates from  $\pm 15V$  or  $\pm 12V$  supplies
- Edge-triggered; No pipeline delays
- Unipolar 0 to +10V input range



**GENERAL DESCRIPTION**

The ADS-919 is a high-performance, 14-bit, 2MHz sampling A/D converter. This device accurately samples full-scale input signals up to Nyquist frequencies with no missing codes. The ADS-919 features outstanding dynamic performance including a THD of  $-74dB$ .

Housed in a small 24-pin DDIP or SMT (gull-wing) package, the functionally complete ADS-919 contains a fast-settling sample-hold amplifier, a subranging (two-pass) A/D converter, a precise voltage reference, timing/control logic, and error-correction circuitry. Digital input and output levels are TTL.

Requiring  $\pm 15V$  (or  $\pm 12V$ ) and +5V supplies, the ADS-919 typically dissipates 1.8W (1.5W for  $\pm 12V$ ). The unit is offered with a unipolar input (0 to +10V). Models are available for use in either commercial (0 to  $+70^{\circ}C$ ) or military ( $-55$  to  $+125^{\circ}C$ ) operating temperature ranges. Applications include radar, sonar, spectrum analysis, and graphic/medical imaging.

**INPUT/OUTPUT CONNECTIONS**

PIN	FUNCTION	PIN	FUNCTION
1	BIT 14 (LSB)	24	$-12V/-15V$ SUPPLY
2	BIT 13	23	ANALOG GROUND
3	BIT 12	22	$+12V/+15V$ SUPPLY
4	BIT 11	21	$+10V$ REFERENCE OUT
5	BIT 10	20	ANALOG INPUT
6	BIT 9	19	ANALOG GROUND
7	BIT 8	18	BIT 1 (MSB)
8	BIT 7	17	BIT 2
9	BIT 6	16	START CONVERT
10	BIT 5	15	$\overline{EOC}$
11	BIT 4	14	DIGITAL GROUND
12	BIT 3	13	$+5V$ SUPPLY

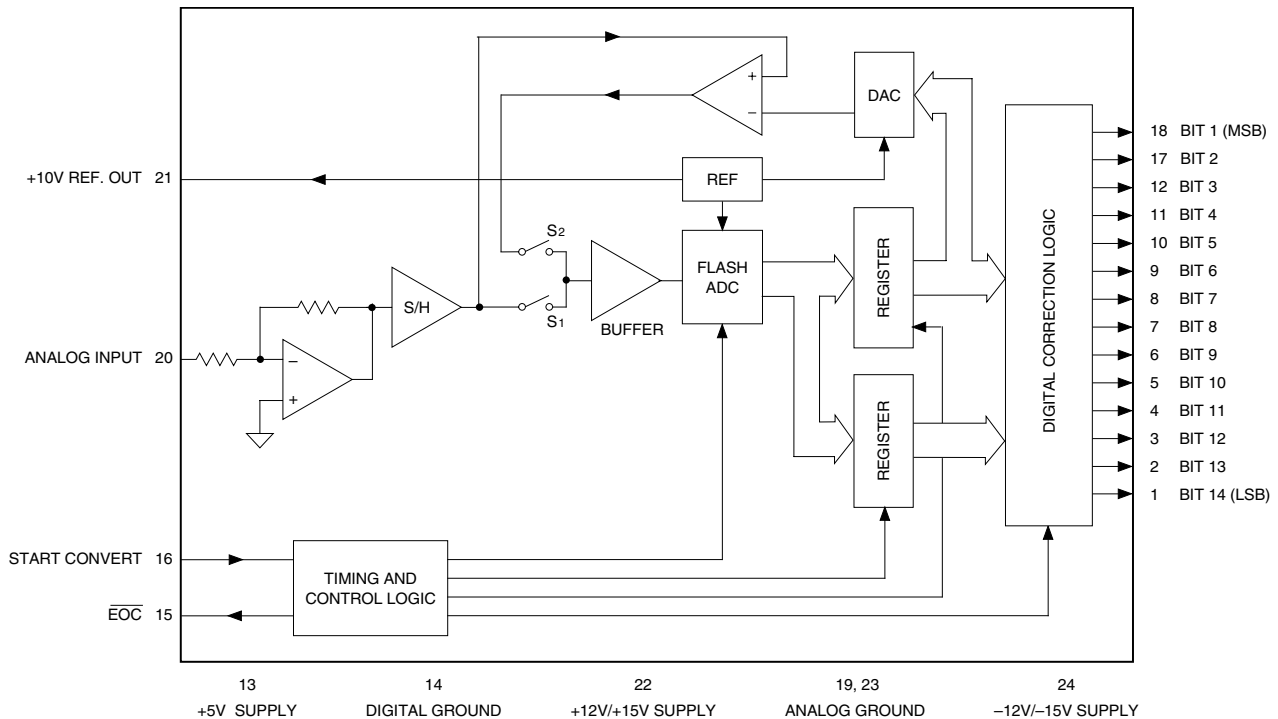


Figure 1. ADS-919 Functional Block Diagram

**ABSOLUTE MAXIMUM RATINGS**

PARAMETERS	LIMITS	UNITS
+12V/+15V Supply (Pin 22)	0 to +16	Volts
-12V/-15V Supply (Pin 24)	0 to -16	Volts
+5V Supply (Pin 13)	0 to +6	Volts
Digital Input (Pin 16)	-0.3 to +VDD +0.3	Volts
Analog Input (Pin 20)	-4 to +17	Volts
Lead Temperature (10 seconds)	+300	°C

**PHYSICAL/ENVIRONMENTAL**

PARAMETERS	MIN.	TYP.	MAX.	UNITS
<b>Operating Temp. Range, Case</b> ADS-919MC, GC ADS-919MM, GM	0	—	+70	°C
	-55	—	+125	°C
<b>Thermal Impedance</b> θjc θca		6 24		°C/Watt °C/Watt
	-65	—	+150	°C
<b>Storage Temperature</b>	24-pin, metal-sealed, ceramic DDIP or SMT 0.42 ounces (12 grams)			
<b>Package Type</b>				
<b>Weight</b>				

**FUNCTIONAL SPECIFICATIONS**

(TA = +25°C, ±VCC = ±15V (or ±12V), +VDD = +5V, 2MHz sampling rate, and a minimum 1 minute warmup ① unless otherwise specified.)

ANALOG INPUT	+25°C			0 to +70°C			-55 to +125°C			UNITS
	MIN.	TYP.	MAX.	MIN.	TYP.	MAX.	MIN.	TYP.	MAX.	
Input Voltage Range ②	—	0 to +10	—	—	0 to +10	—	—	0 to +10	—	Volts
Input Resistance	—	1	—	—	1	—	—	1	—	kΩ
Input Capacitance	—	7	15	—	7	15	—	7	15	pF
<b>DIGITAL INPUT</b>										
<b>Logic Levels</b>										
Logic "1"	+2.0	—	—	+2.0	—	—	+2.0	—	—	Volts
Logic "0"	—	—	+0.8	—	—	+0.8	—	—	+0.8	Volts
Logic Loading "1"	—	—	+20	—	—	+20	—	—	+20	µA
Logic Loading "0"	—	—	-20	—	—	-20	—	—	-20	µA
Start Convert Positive Pulse Width ③	20	200	—	20	200	—	20	200	—	ns
<b>STATIC PERFORMANCE</b>										
Resolution	—	14	—	—	14	—	—	14	—	Bits
Integral Nonlinearity (fin = 10kHz)	—	±0.5	—	—	±0.75	—	—	±1	—	LSB
Differential Nonlinearity (fin = 10kHz)	—	±0.5	±0.95	—	±0.5	±0.95	—	±0.5	±0.99	LSB
Full Scale Absolute Accuracy	—	±0.1	±0.3	—	±0.2	±0.4	—	±0.4	±0.8	%FSR
Unipolar Offset Error (Tech Note 2)	—	±0.1	±0.25	—	±0.2	±0.4	—	±0.4	±1.25	%FSR
Gain Error (Tech Note 2)	—	±0.1	±0.3	—	±0.3	±0.5	—	±0.5	±1	%
No Missing Codes (fin = 10kHz)	14	—	—	14	—	—	14	—	—	Bits
<b>DYNAMIC PERFORMANCE</b>										
<b>Peak Harmonics (-0.5dB)</b>										
dc to 500kHz	—	-76	-72	—	-76	-70	—	-74	-69	dB
500kHz to 1MHz	—	-76	-70	—	-76	-70	—	-74	-69	dB
<b>Total Harmonic Distortion (-0.5dB)</b>										
dc to 500kHz	—	-74	-70	—	-74	-70	—	-73	-69	dB
500kHz to 1MHz	—	-74	-70	—	-74	-70	—	-73	-68	dB
<b>Signal-to-Noise Ratio</b> (w/o distortion, -0.5dB)										
dc to 500kHz	74	77	—	74	77	—	71	76	—	dB
500kHz to 1MHz	74	77	—	74	77	—	71	75	—	dB
<b>Signal-to-Noise Ratio ④</b> (& distortion, -0.5dB)										
dc to 500kHz	70	74	—	70	74	—	68	73	—	dB
500kHz to 1MHz	70	74	—	70	74	—	68	72	—	dB
<b>Two-Tone Intermodulation</b>										
<b>Distortion</b> (fin = 200kHz, 500kHz, fs = 2MHz, -0.5dB)	—	-80	—	—	-80	—	—	-79	—	dB
<b>Noise</b>	—	300	—	—	350	—	—	450	—	µVrms
<b>Input Bandwidth (-3dB)</b>										
Small Signal (-20dB input)	—	9	—	—	9	—	—	9	—	MHz
Large Signal (-0.5dB input)	—	8	—	—	8	—	—	8	—	MHz
<b>Feedthrough Rejection</b> (fin = 1MHz)	—	82	—	—	82	—	—	82	—	dB
<b>Slew Rate</b>	—	±200	—	—	±200	—	—	±200	—	V/µs
<b>Aperture Delay Time</b>	—	±20	—	—	±20	—	—	±20	—	ns
<b>Aperture Uncertainty</b>	—	5	—	—	5	—	—	5	—	ps rms
<b>S/H Acquisition Time</b> (to ±0.003%FSR, 10V step)	150	190	230	150	190	230	150	190	230	ns
<b>Overvoltage Recovery Time ⑤</b>	—	400	500	—	400	500	—	400	500	ns
<b>A/D Conversion Rate</b>	2	—	—	2	—	—	2	—	—	MHz

ANALOG OUTPUT	+25°C			0 to +70°C			-55 to +125°C			UNITS
	MIN.	TYP.	MAX.	MIN.	TYP.	MAX.	MIN.	TYP.	MAX.	
<b>Internal Reference</b>										
Voltage	+9.95	+10	+10.05	+9.95	+10	+10.05	+9.95	+10	+10.05	Volts
Drift	—	±5	—	—	±5	—	—	±5	—	ppm/°C
<b>External Current</b>	—	—	1.5	—	—	1.5	—	—	1.5	mA
<b>DIGITAL OUTPUTS</b>										
<b>Logic Levels</b>										
Logic "1"	+2.4	—	—	+2.4	—	—	+2.4	—	—	Volts
Logic "0"	—	—	+0.4	—	—	+0.4	—	—	+0.4	Volts
Logic Loading "1"	—	—	-4	—	—	-4	—	—	-4	mA
Logic Loading "0"	—	—	+4	—	—	+4	—	—	+4	mA
<b>Delay, Falling Edge of EOC to Output Data Valid</b>	—	—	35	—	—	35	—	—	35	ns
<b>Output Coding</b>	Straight Binary									
<b>POWER REQUIREMENTS, ±15V</b>										
<b>Power Supply Ranges</b>										
+15V Supply	+14.5	+15	+15.5	+14.5	+15	+15.5	+14.5	+15	+15.5	Volts
-15V Supply	-14.5	-15	-15.5	-14.5	-15	-15.5	-14.5	-15	-15.5	Volts
+5V Supply	+4.75	+5	+5.25	+4.75	+5	+5.25	+4.75	+5	+5.25	Volts
<b>Power Supply Currents</b>										
+15V Supply	—	+45	+60	—	+45	+60	—	+45	+60	mA
-15V Supply	—	-45	-60	—	-45	-60	—	-45	-60	mA
+5V Supply	—	+85	+95	—	+85	+95	—	+85	+95	mA
<b>Power Dissipation</b>	—	1.8	2.2	—	1.8	2.2	—	1.8	2.2	Watts
<b>Power Supply Rejection</b>	—	—	±0.02	—	—	±0.02	—	—	±0.02	%FSR/%V
<b>POWER REQUIREMENTS, ±12V</b>										
<b>Power Supply Ranges</b>										
+12V Supply	+11.5	+12	+12.5	+11.5	+12	+12.5	+11.5	+12	+12.5	Volts
-12V Supply	-11.5	-12	-12.5	-11.5	-12	-12.5	-11.5	-12	-12.5	Volts
+5V Supply	+4.75	+5	+5.25	+4.75	+5	+5.25	+4.75	+5	+5.25	Volts
<b>Power Supply Currents</b>										
+12V Supply	—	+45	+65	—	+45	+65	—	+45	+65	mA
-12V Supply	—	-45	-60	—	-45	-60	—	-45	-60	mA
+5V Supply	—	+85	+95	—	+85	+95	—	+85	+95	mA
<b>Power Dissipation</b>	—	1.5	1.7	—	1.5	1.7	—	1.5	1.7	Watts
<b>Power Supply Rejection</b>	—	—	±0.02	—	—	±0.02	—	—	±0.02	%FSR/%V
<b>Footnotes:</b>										
① All power supplies must be on before applying a start convert pulse. All supplies and the clock (START CONVERT) must be present during warmup periods. The device must be continuously converting during this time. There is a slight degradation in performance when using ±12V supplies.					④ Effective bits is equal to: $\frac{(\text{SNR} + \text{Distortion}) - 1.76 + \left[ 20 \log \frac{\text{Full Scale Amplitude}}{\text{Actual Input Amplitude}} \right]}{6.02}$					
② See Ordering Information for availability of ±5V input range. Contact DATEL for availability of other input voltage ranges.					⑤ This is the time required before the A/D output data is valid after the analog input is back within the specified range.					
③ A 2MHz clock with a 200ns wide start convert pulse is used for all production testing. See Timing Diagram for more details.										

**TECHNICAL NOTES**

- Obtaining fully specified performance from the ADS-919 requires careful attention to pc-card layout and power supply decoupling. The device's analog and digital ground systems are connected to each other internally. For optimal performance, tie all ground pins (14, 19 and 23) directly to a large **analog** ground plane beneath the package.  
  
Bypass all power supplies and the REFERENCE OUTPUT (pin 21) to ground with 4.7µF tantalum capacitors in parallel with 0.1µF ceramic capacitors. Locate the bypass capacitors as close to the unit as possible. If the user-installed offset and gain adjusting circuit shown in Figure 2 is used, also locate it as close to the ADS-919 as possible.
- The ADS-919 achieves its specified accuracies without the need for external calibration. If required, the device's small

- initial offset and gain errors can be reduced to zero using the input circuit of Figure 2. When using this circuit, or any similar offset and gain-calibration hardware, make adjustments following warmup. To avoid interaction, always adjust offset before gain.
- When operating the ADS-919 from ±12V supplies, do not drive external circuitry with the REFERENCE OUTPUT. The reference's accuracy and drift specifications may not be met, and loading the circuit may cause accuracy errors within the converter.
  - Applying a start convert pulse while a conversion is in progress (EOC = logic "1") initiates a new and inaccurate conversion cycle. Data for the interrupted and subsequent conversions will be invalid.

**CALIBRATION PROCEDURE**

(Refer to Figures 2 and 3)

Any offset and/or gain calibration procedures should not be implemented until devices are fully warmed up. To avoid interaction, offset must be adjusted before gain. The ranges of adjustment for the circuit of Figure 2 are guaranteed to compensate for the ADS-919's initial accuracy errors and may not be able to compensate for additional system errors.

All fixed resistors in Figure 2 should be metal-film types, and multturn potentiometers should have TCR's of 100ppm/°C or less to minimize drift with temperature.

A/D converters are calibrated by positioning their digital outputs exactly on the transition point between two adjacent digital output codes. This can be accomplished by connecting LED's to the digital outputs and adjusting until certain LED's "flicker" equally between on and off. Other approaches employ digital comparators or microcontrollers to detect when the outputs change from one code to the next.

For the ADS-919, offset adjusting is normally accomplished at the point where the output bits are 0's and the LSB just changes from a 0 to a 1. This digital output transition ideally occurs when the applied analog input is +½ LSB (+305µV).

Gain adjusting is accomplished when all bits are 1's and the LSB just changes from a 1 to a 0. This transition ideally occurs when the analog input is at +full scale minus 1½ LSB's (+9.999085V).

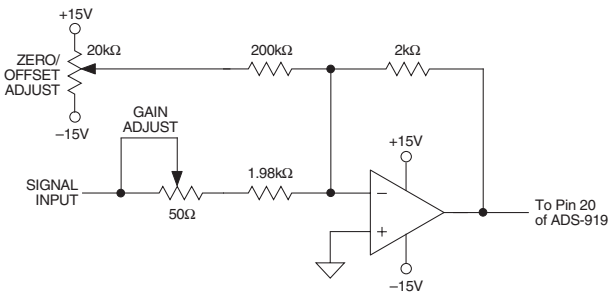


Figure 2. ADS-919 Calibration Circuit

**Zero/Offset Adjust Procedure**

1. Apply a train of pulses to the START CONVERT input (pin 16) so the converter is continuously converting. If using LED's on the outputs, a 200kHz conversion rate will reduce flicker.
2. Apply +305µV to the ANALOG INPUT (pin 20).
3. Adjust the offset potentiometer until the output bits are all 0's and the LSB flickers between 0 and 1.

**Gain Adjust Procedure**

1. Apply +9.999085V to the ANALOG INPUT (pin 20).
2. Adjust the gain potentiometer until the output bits are all 1's and the LSB flickers between 1 and 0.

Table 1. Zero and Gain Adjust

INPUT VOLTAGE RANGE	ZERO ADJUST +½ LSB	GAIN ADJUST +FS -1½ LSB
0 to +10V	+305µV	+9.999085V

Table 2. Output Coding

INPUT VOLTAGE (0 TO +10V)	UNIPOLAR SCALE	DIGITAL OUTPUT			
		MSB			LSB
+9.999390	+FS - 1LSB	11	1111	1111	1111
+7.500000	+3/4FS	11	0000	0000	0000
+5.000000	+1/2FS	10	0000	0000	0000
+2.500000	+1/4FS	01	0000	0000	0000
+0.000610	+1LSB	00	0000	0000	0001
0.000000	0	00	0000	0000	0000

Coding is straight binary; 1LSB = 610µV.

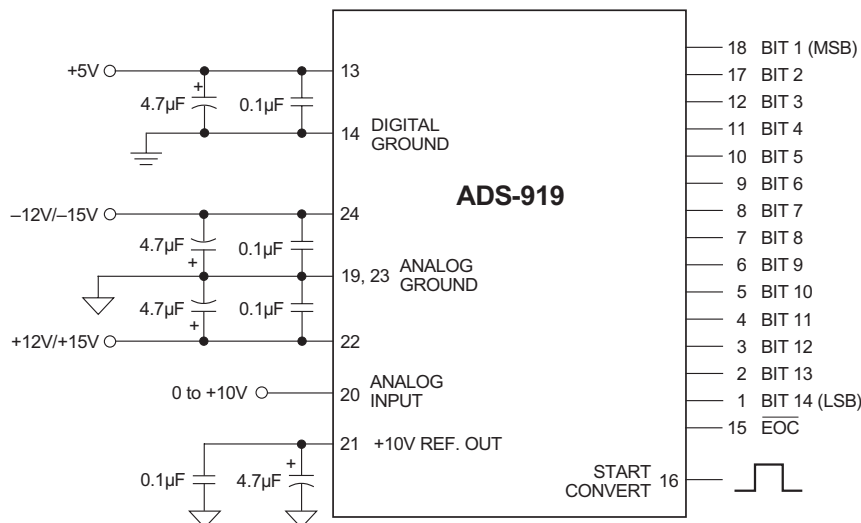


Figure 3. Typical ADS-919 Connection Diagram

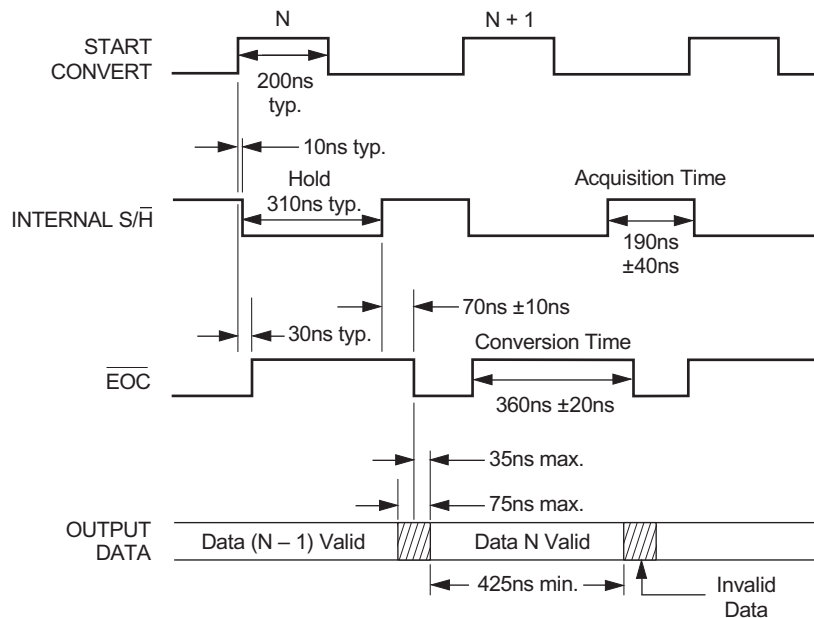
**THERMAL REQUIREMENTS**

All DATEL sampling A/D converters are fully characterized and specified over operating temperature (case) ranges of 0 to +70°C and -55 to +125°C. All room-temperature ( $T_A = +25^\circ\text{C}$ ) production testing is performed without the use of heat sinks or forced-air cooling. Thermal impedance figures for each device are listed in their respective specification tables.

These devices do not normally require heat sinks, however, standard precautionary design and layout procedures should be used to ensure devices do not overheat. The ground and power planes beneath the package, as well as all pcb signal runs to and from the device, should be as heavy as possible to help conduct heat away from the package.

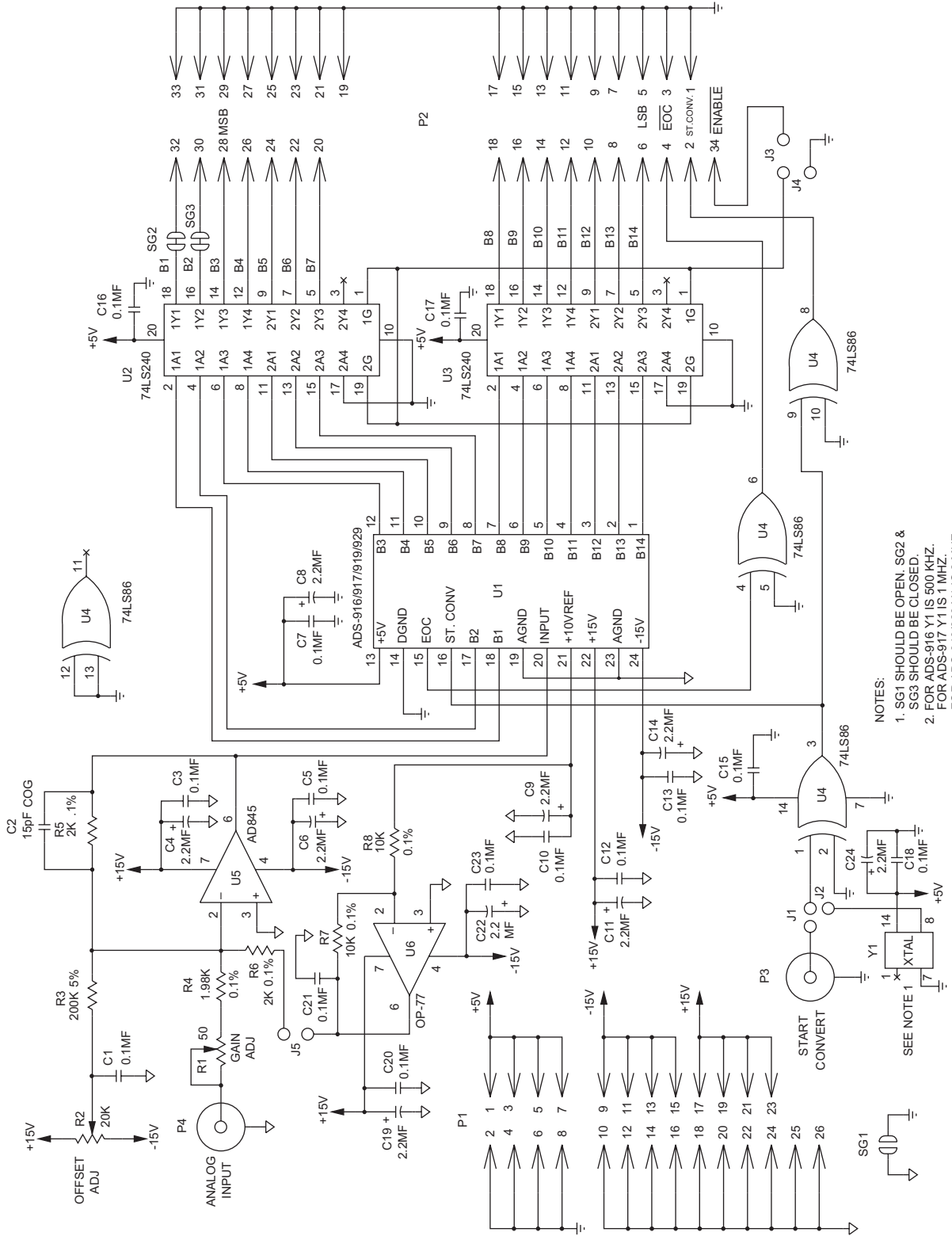
Electrically-insulating, thermally-conductive "pads" may be installed underneath the package. Devices should be soldered to boards rather than "socketed", and of course, minimal air flow over the surface can greatly help reduce the package temperature.

In more severe ambient conditions, the package/junction temperature of a given device can be reduced dramatically (typically 35%) by using one of DATEL's HS Series heat sinks. See Ordering Information for the assigned part number. See page 1-183 of the DATEL Data Acquisition Components Catalog for more information on the HS Series. Request DATEL Application Note AN-8, "Heat Sinks for DIP Data Converters", or contact DATEL directly, for additional information.



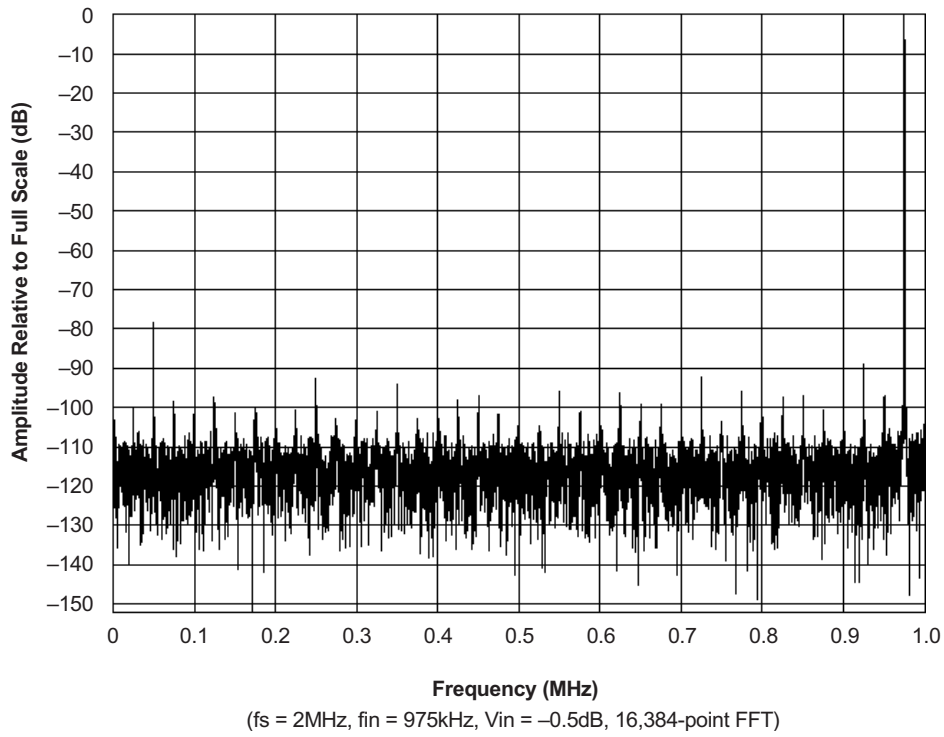
- Notes: 1.  $f_s = 2\text{MHz}$ .
2. The ADS-919 is an edge-triggered device. All internal operations are triggered by the rising edge of the start convert pulse, which may be as narrow as 20nsec. All production testing is performed at a 2MHz sampling rate with 200nsec wide start pulses. For lower sampling rates, wider start pulses may be used, however, a minimum pulse width low of 20nsec must be maintained.

**Figure 4. ADS-919 Timing Diagram**

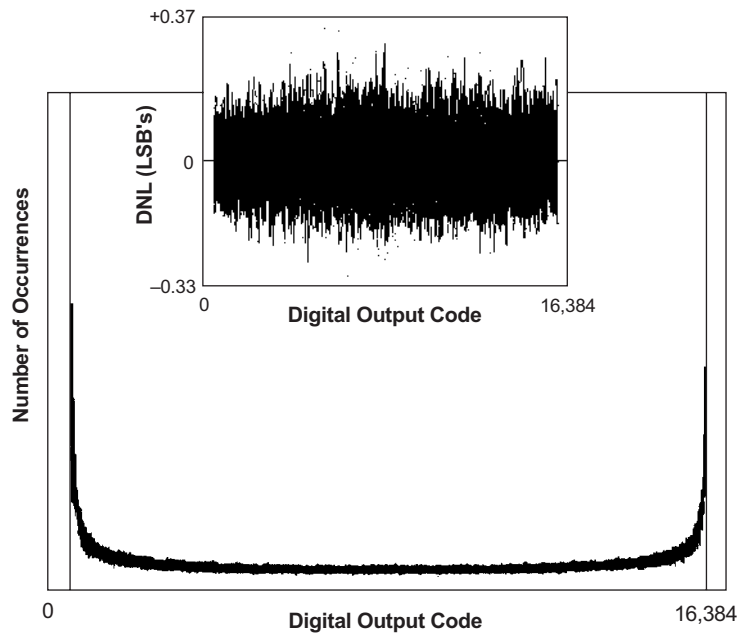


- NOTES:
1. SG1 SHOULD BE OPEN. SG2 & SG3 SHOULD BE CLOSED.
  2. FOR ADS-916 Y1 IS 500 KHZ. FOR ADS-917 Y1 IS 1.1 MHZ. FOR ADS-919/929 Y1 IS 2 MHZ.

Figure 5. ADS-919 Evaluation Board Schematic

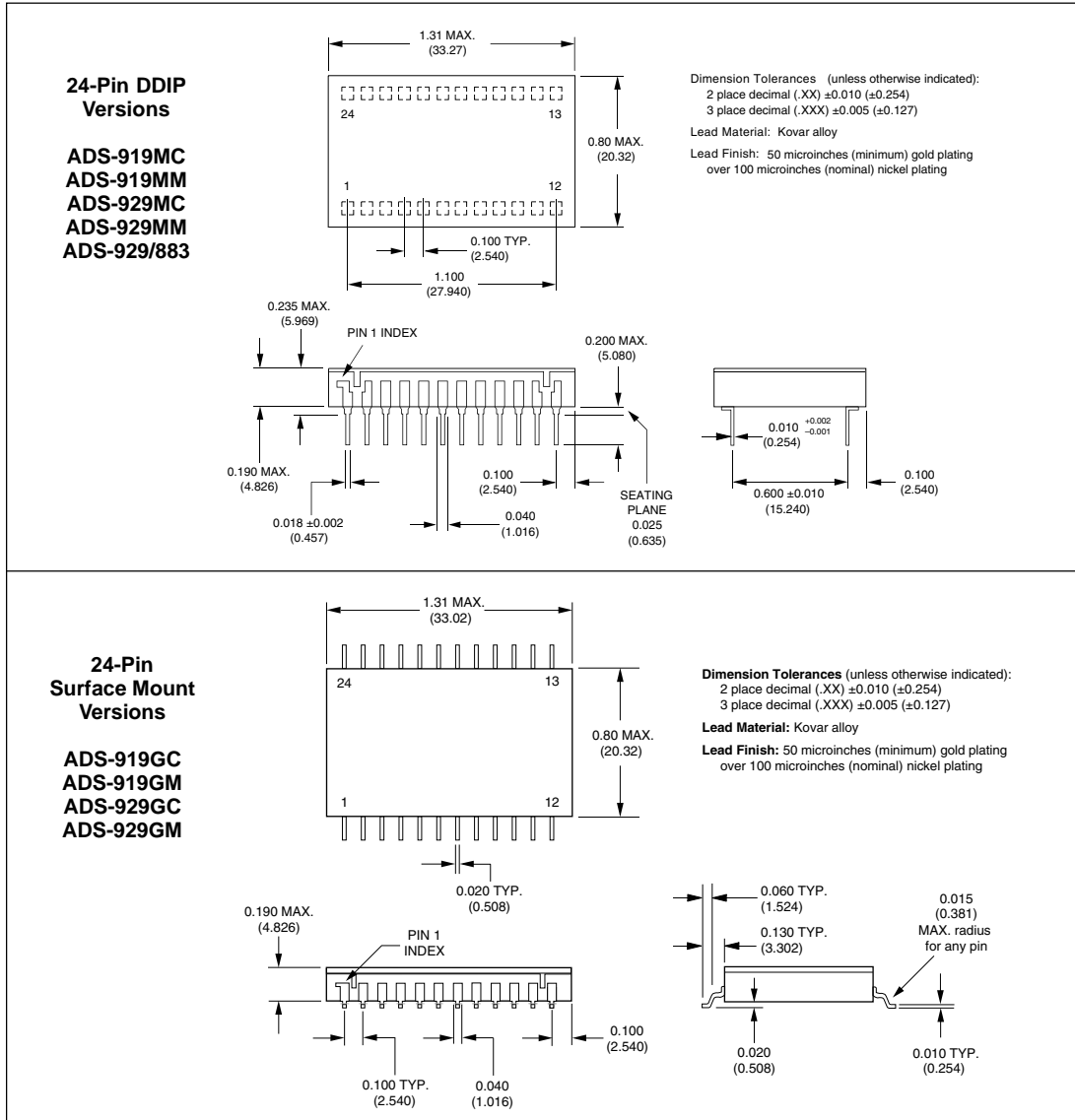


**Figure 6. ADS-919 FFT Analysis**



**Figure 7. ADS-919 Histogram and Differential Nonlinearity**

MECHANICAL DIMENSIONS INCHES (mm)



ORDERING INFORMATION

MODEL NUMBER	OPERATING TEMP. RANGE	ANALOG INPUT	ACCESSORIES
ADS-919MC	0 to +70°C	Unipolar (0 to +10V)	ADS-B919/929 Evaluation Board (without ADS-919)
ADS-919MM	-55 to +125°C	Unipolar (0 to +10V)	HS-24 Heat Sinks for all ADS-919/929 DDIP models
ADS-919GC	0 to +70°C	Unipolar (0 to +10V)	Receptacles for PC board mounting can be ordered through AMP Inc. Part #3-331272-8 (Component Lead Socket), 24 required.
ADS-919GM	-55 to +125°C	Unipolar (0 to +10V)	For MIL-STD-883 product specifications, contact DATEL.
ADS-929MC	0 to +70°C	Bipolar ( $\pm 5V$ )*	* For information, see ADS-929 data sheet.
ADS-929MM	-55 to +125°C	Bipolar ( $\pm 5V$ )*	
ADS-929/883	-55 to +125°C	Bipolar ( $\pm 5V$ )*	
ADS-929GC	0 to +70°C	Bipolar ( $\pm 5V$ )*	
ADS-929GM	-55 to +125°C	Bipolar ( $\pm 5V$ )*	