

---

## SINGLE-CHIP VOICE RECORD/PLAYBACK DEVICES

### 1. GENERAL DESCRIPTION

GPCR20A is a highly integrated circuit that contains all of the necessary functions for providing high quality voice recording and playback. In order to provide the high quality voice, 4 times over sampling and 19 level digital filter technology are used to reduce the noise level. Easy-to-use, low power consumption and compact size are the tremendous features of GPCR20A. Total of 512K bits SRAM are capable of storing approximately 20 seconds of audio or speech voice (@ 6KHz sampling rate). PWM speaker driver offers the simplest output solution for users. Furthermore, the wide operating power supply (2.4V - 5.5V) provides various battery options to select. The development team of GPCR20A designs especially for compact message recorder, recordable toys and other similar products. It is willing to provide the best cost/performance ratio for users.

### 2. FEATURES

- Nature, high-quality playback suitable for voice, music, and tones.
- Single-chip voice record and playback device.
- Microphone differential input and preamplifier output
- Low pass amplifier input
- Automatic gain control
- PWM speaker driver
- Built in 128Kx4bits SRAM, address space (0-1FFFF)
- Wide operating voltage range: 2.4V - 5.5V
- Frequency of playing and recording: 4K - 10KHz
- 20 sec recording time @ 6.0KHz
- One voice box with 20 sec or 2 voice boxes with 10 sec (Bonding option select one or two voice box)
- Edge or level-hold recording trigger (Bonding option select edge or level trigger)
- Prompt beep sound (Bonding option select beep or not)
- LEDs indication for recording starting and ending or playing starting and ending.
- Edge trigger for playback triggers.
- Auto-playback function after ending of recording (Bonding option select auto-playback or not).

### 3. SIGNAL DESCRIPTIONS

Mnemonic	PIN No.	Type	Description
ROSC	10	I	The "ROSC" pin connects with an external resistor to VDD. To cooperate with a variable resistor, the frequency for recording and playing are adjustable to fulfill user's specifications.
REC0	20	I	The record-request pin for one voice box (20 sec) or the 1'st box of al 2 boxes (10 sec for each). REC0 with pull high resistor, is active in low and start recording to 1'st voice box
REC1	21	I	REC1, The record-request pin for the 2'nd box of 2 boxes (10 sec for each). REC1 with pull high resistor, is active in low and start recording to 2'nd voice box.
PLAY0	18	I	PLAY0 The play-request pin for one voice box (20 sec) or the 1'st box of 2 boxes (10 sec for each). PLAY0 with pull high resistor, is active in low and start playing from 1'st voice box
PLAY1	19	I	PLAY1, The play-request pin for the 2'nd box of total 2 boxes (10 sec for each). PLAY1 With pull high resistor, is active in low and start playing from 2'nd voice box
MICP	2	I	Microphone differential positive input
MICN	3	I	Microphone differential negative input
AGC	5	I	Automatic gain control input
MICOUT	4	O	Analog output of MIC preamplifier
ADIP	6	I	Analog input of low pass filter
REC_BUSY	17	O	The state of this pin will be low while recording.
AUDP	23	O	PWM driver positive output
AUDN	24	O	PWM driver negative output
PVDD, PVSS	22, 25	Power	PWM power and ground
AVDD, AVSS	8, 1	Power	Analog power and ground
VDD, VSS	13, 11	Power	Digital power and ground
PLAY_BUSY	16	O	The state of this pin is low while playing.
KEY_OPT (*1)	7	I	Bounding option for select one voice box or two voice boxes
EDGE_OPT (*2)	12	I	Bounding option for KEY is active in level trigger or edge trigger
AUTO_OPT (*3)	7	I	Bounding option for REC KEY auto-play-back function when record is finished.
BEEP_OPT (*4)	9	I	Bounding option for BEEP sound is enable or disable
TEST	15	I	TEST pin active high is in test mode

(\*1) KEY\_OPT: Bounding option for select one voice box or two voice boxes,  
IF KEY\_OPT = 0 → One voice box mode 512K.  
IF KEY\_OPT = 1 → Two voice box mode 256K for each.  
Default setting is 0

(\*2) EDGE\_OPT: Bounding option for REC KEY auto-play-back function when record is finished.  
IF EDGE\_OPT = 0 → level trigger.  
IF EDGE\_OPT = 1 → edge trigger.  
Default setting is 0

(\*3) AUTO\_OPT: Bounding option for REC KEY auto-play-back function when record is finished.  
IF AUTO\_OPT = 0 → No auto play when record is finished.  
IF AUTO\_OPT = 1 → Auto play when record is finished.  
Default setting is 0

(\*4) BEEP\_OPT: Bounding option for BEEP sound is enable or disable.  
IF BEEP\_OPT = 0 → No beep mode.  
IF BEEP\_OPT = 1 → Beep mode  
Default setting is 0

If there's no bounding option selected, the default setting will be kept low.

#### 4. FUNCTIONAL DESCRIPTIONS

EDGE\_OPT is low (level trigger mode)

KEY\_OPT is low (one voice box mode)

AUTO\_OPT is low (no auto play when rec is finished)

BEEP\_OPT is high (beep mode)

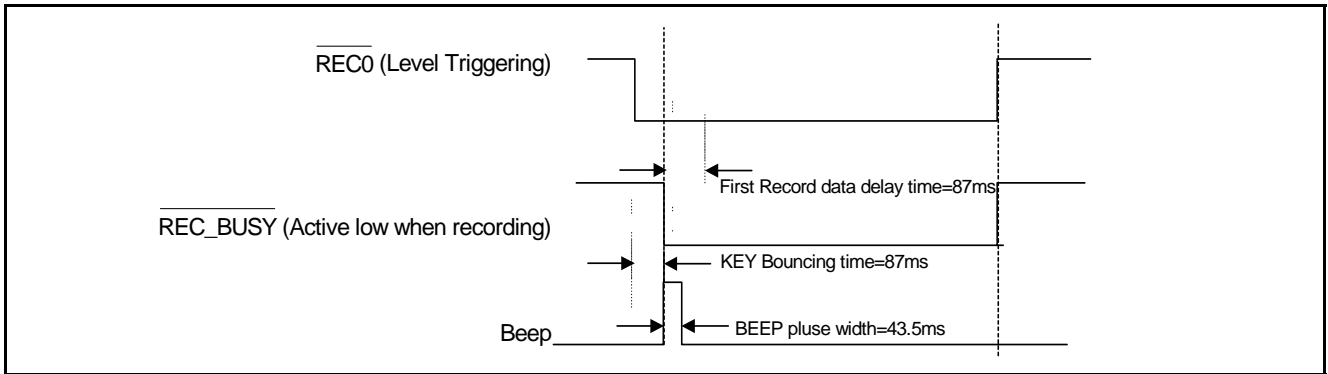

Explain: GPCR20A in level trigger mode, when  $\overline{\text{REC0}}$  is pressed,  $\overline{\text{REC0}}$  is active at low voltage.

Bouncing after KEY\_ bouncing time (87ms), a BEEP sound is played.

Waiting delay time (87ms), GPCR20A start recording.

When  $\overline{\text{REC0}}$  is released,  $\overline{\text{REC0}}$  is not active, GPCR20A stop recording.

EDGE\_OPT is high (edge trigger mode)

KEY\_OPT is high (two voice box mode)

AUTO\_OPT is low (no auto play when rec is finished)

BEEP\_OPT is high (beep mode)

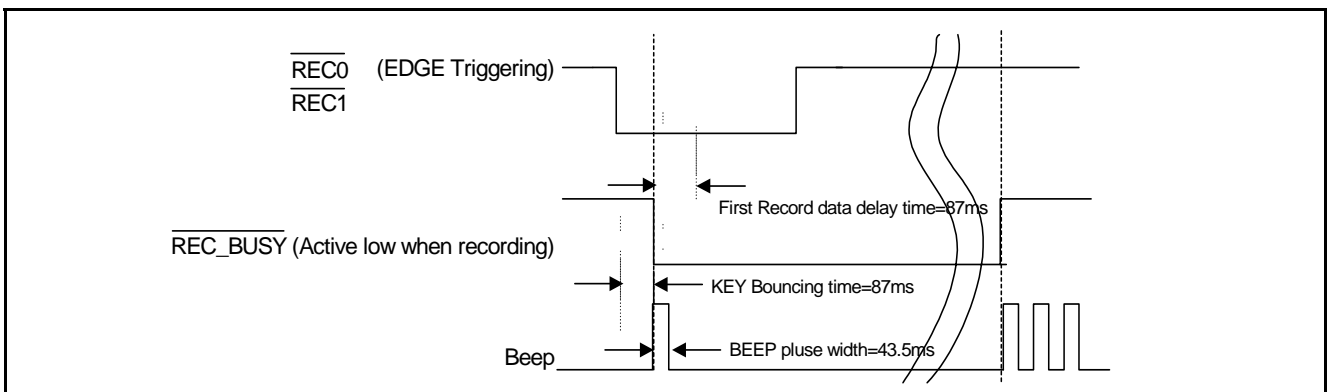

Explain: GPCR20A in edge trigger mode, when  $\overline{\text{REC0}}$  is pressed,  $\overline{\text{REC0}}$  B is active at low voltage.

Bouncing after KEY\_ bouncing time (87ms), a BEEP sound is played.

Waiting delay time (87ms), GPCR20A start recording.

When  $\overline{\text{REC0}}$  is released, GPCR20A continue to record until sound data in voice box is full.

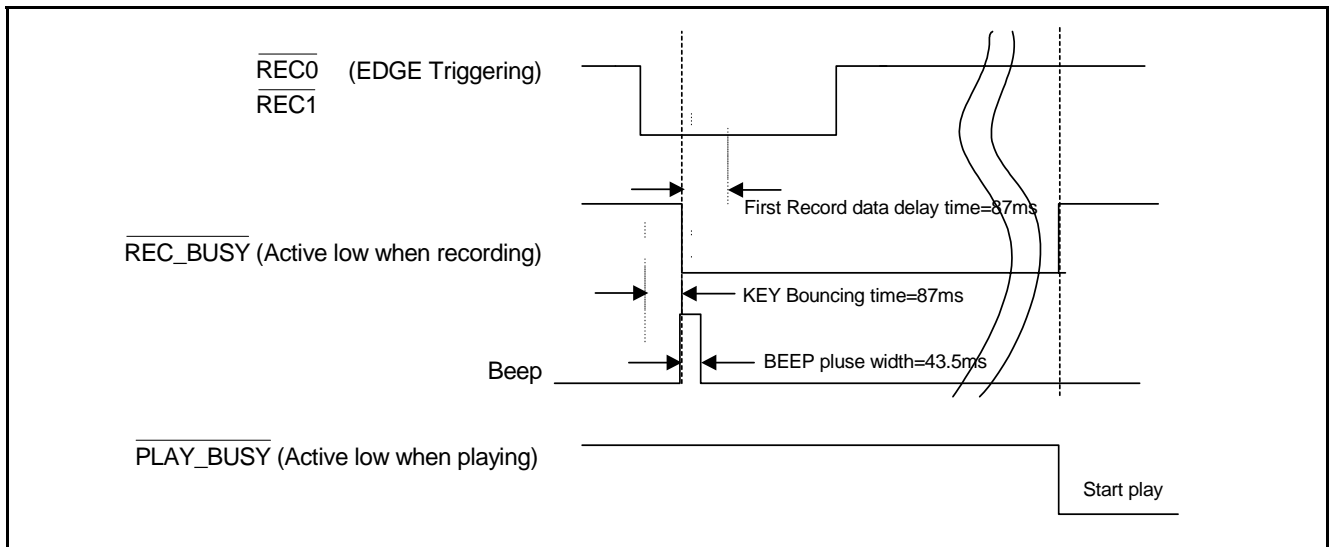

Explain: GPCR20A in edge trigger and auto-playback mode,  
 REC0 is pressed; REC0 is active at low voltage.  
 After KEY\_bouncing time (87ms), a BEEP sound is played.  
 Waiting delay time (87ms), GPCR20A start recording.  
 REC0 is released, GPCR20A continue to record until sound data in voice box is full.  
 Then GPCR20A start to play-back sound recorded in 1'st voice box.

EDGE\_OPT is low (level trigger mode)  
 KEY\_OPT is high (two voice box mode)  
 AUTO\_OPT is high (auto play mode)  
 BEEP\_OPT is high (beep mode)

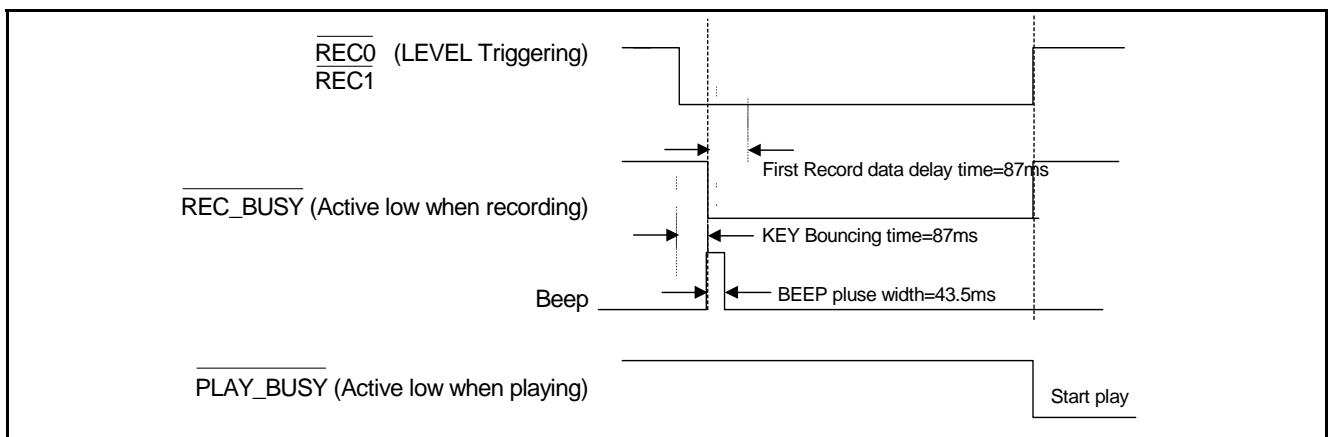

Explain: GPCR20A in level trigger and auto-playback mode,  
 REC0 is pressed, REC0 is active at low voltage.  
 After KEY\_bouncing time (87ms), a BEEP sound is played.  
 Waiting delay time (87ms), GPCR20A start recording.  
 REC0 is released, GPCR20A start to play-back sound recorded in 1'st voice box.

EDGE\_OPT is low (level trigger mode)  
 KEY\_OPT is high (two voice box mode)  
 AUTO\_OPT is high (auto play mode)  
 BEEP\_OPT is low (no mode)

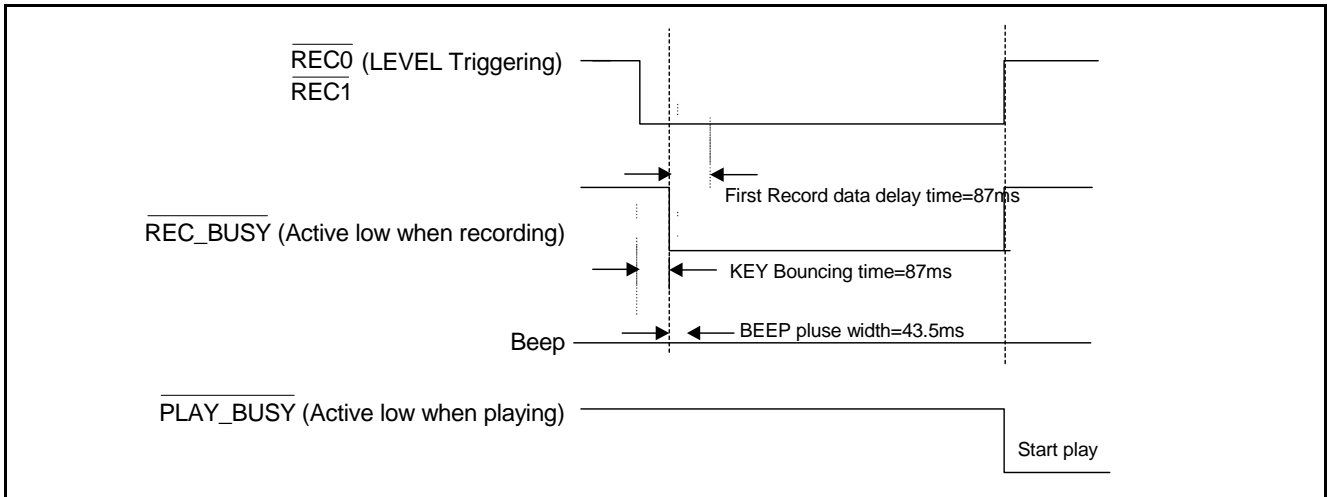

Explain: GPCR20A in level trigger, auto-playback mode and NO beep mode,  
 REC0 is pressed; REC0 is active at low voltage.  
 After KEY\_bouncing time (87ms), none BEEP sound is played.  
 Waiting delay time (87ms), GPCR20A start recording.  
 REC0 is released, GPCR20A start to play-back sound recorded in 1'st voice box.

KEY\_OPT is high (two voice box mode)

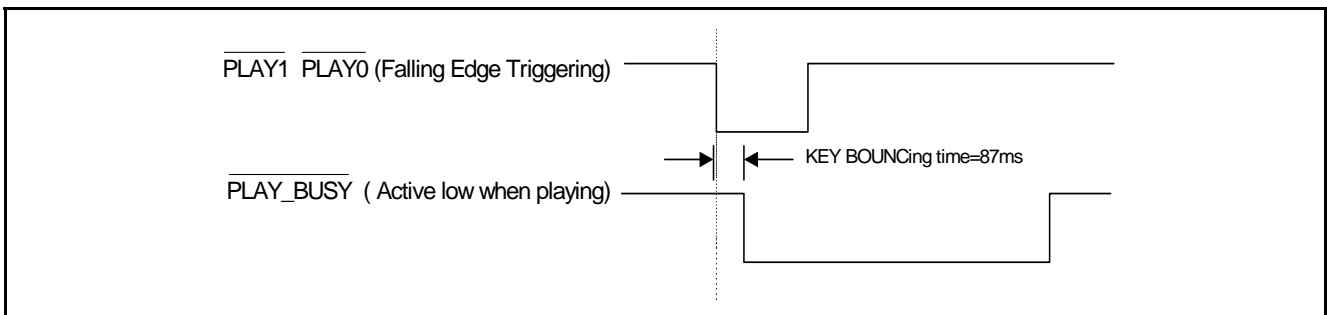

Explain: PLAY0 is pressed; PLAY0 is active at low voltage.  
 After KEY\_bouncing time (87ms), GPCR20A start to play sound recorded in 1'st voice box.

5. ELECTRICAL SPECIFICATIONS

Characteristics	Symbol	Limit			Unit	Test condition
		Min.	Typ.	Max.		
Operating Temperature	TEMP	-10	25	70	°C	-
Operating Voltage	VDD	2.4	-	5.5	V	Temperature = 25°C
Operating Current	I <sub>CC1</sub>	-	60	-	mA	No load, VDD = 3.0V
	I <sub>CC2</sub>	-	-	120		8Ω Speaker, VDD = 3.0V
Standby Current	I <sub>SB</sub>	-	1.0	10	μA	VDD = 3.0V
Input High Voltage	V <sub>IH</sub>	0.7 x VDD	-	VDD	V	-
Input Low Voltage	V <sub>IL</sub>	VSS	-	0.2 x VDD	V	-
Input pull high Resistor	R <sub>I</sub>		300	-	KΩ	VDD = 3.0V
Output High Voltage	V <sub>OH</sub>	2.6	-	-	V	VDD = 3.0V, I <sub>OH</sub> = 2mA
Output Low Voltage	V <sub>OL</sub>	-	-	0.4	V	VDD = 3.0V, I <sub>OL</sub> = -4mA
Sample Rate	F <sub>S</sub>	4.0K	6.0K	10K	Sa/Sec	VDD = 3.0V
Current of high voltage	I <sub>OH</sub>	-	2.0	-	mA	VDD = 3.0V
Current of low voltage	I <sub>OL</sub>	-	-4.0	-	mA	VDD = 3.0V
Oscillation Resistor	R <sub>OSC</sub>	180K	110K	62K	Ω	VDD = 3.0V

5.1. The Relationship of F<sub>OSC</sub> vs VDD @ R<sub>OSC</sub> = 110KΩ

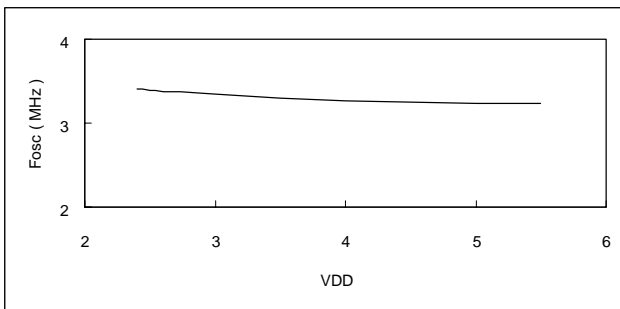

5.2. The Relationship of F<sub>OSC</sub> vs. R<sub>OSC</sub>

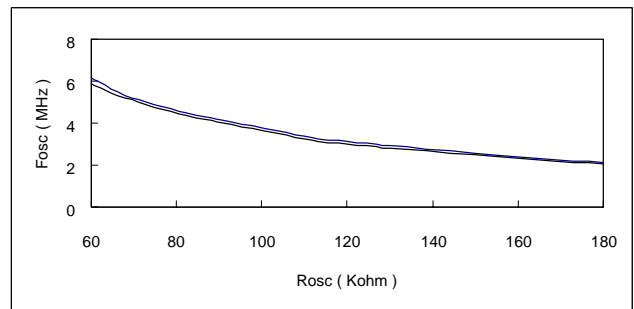

**6. APPLICATION CIRCUITS**

The system is capable of recording as long as the  $\overline{\text{RECx}}$  switch is being pressed (level triggering or edge trigger). The recorded message or audio can be played back when the  $\overline{\text{PLAYx}}$  switch

is pressed (falling edge triggering). When system is recording, the LED light from RELED will be on until the end of recording.

$\overline{\text{RECx}}$  :  $\overline{\text{REC0}}$  or  $\overline{\text{REC1}}$

$\overline{\text{PLAYx}}$  :  $\overline{\text{PLAY0}}$  or  $\overline{\text{PLAY1}}$

**6.1. Best Quality**

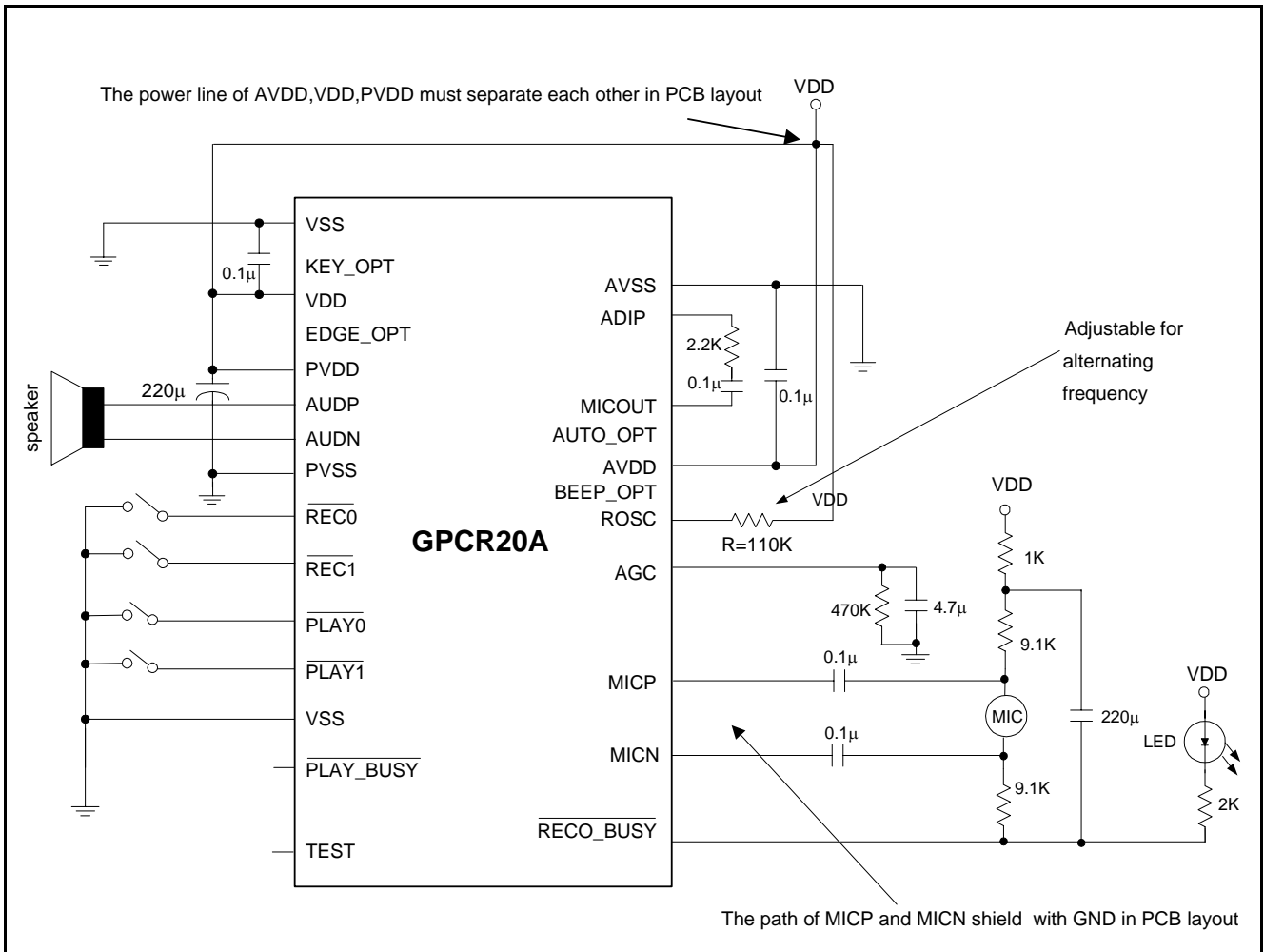

6.2. Best Cost (Reduce Component)

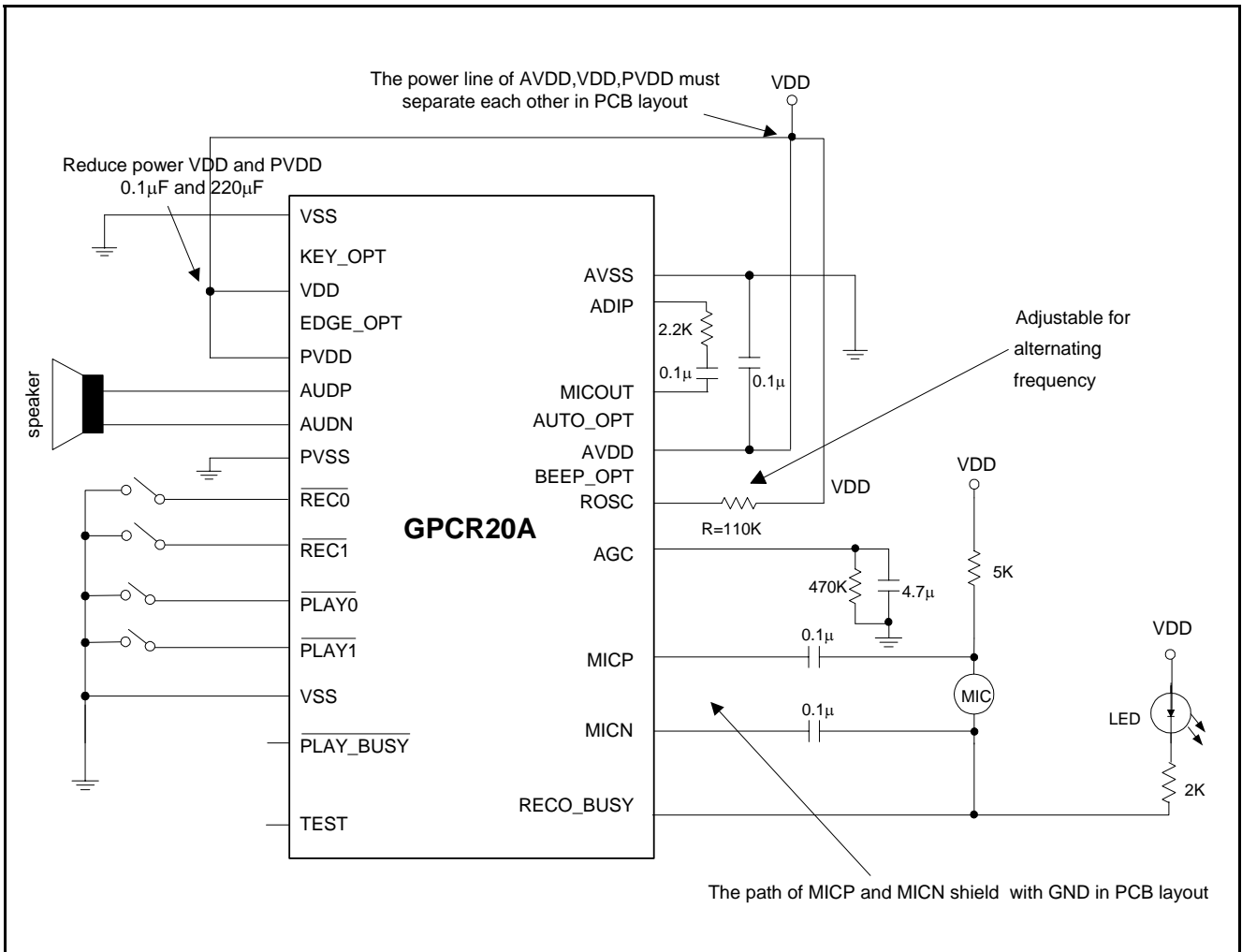

PCB Layout Note:

- 1) The path of MICP and MICN shield with GND (reduce noise comes from MIC)
- 2) The power line of AVDD, VDD, PVDD, ROSC must separate each other. (Reduce noise comes from Power line)
- 3) The ground line of AVSS, VSS, PVSS must separate each other. (Reduce noise comes from Ground)

7. PACKAGE/PAD LOCATIONS

7.1. PAD Assignment

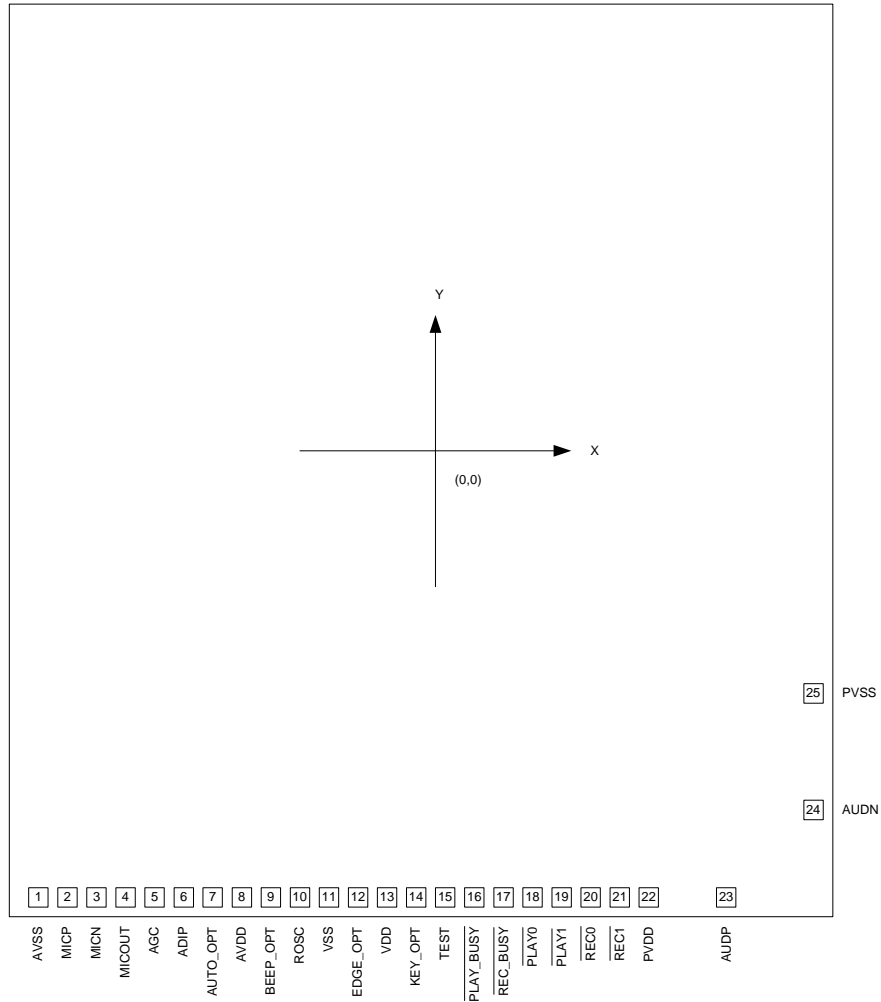

This IC substrate should be connected to VDD

**Note1:** Chip size included scribe line.

**Note2:** To ensure that the IC functions properly, please bond all of VDD and VSS pins.

**Note3:** The 0.1μF capacitor between VDD and VSS should be placed to IC as close as possible.

7.2. Ordering Information

Product number	Package type
GPCR20A - C	Chip form

7.3. PAD Locations

PAD No.	PAD Name	X	Y
1	AVSS	-1558	-1873
2	MICP	-1435	-1873
3	MICN	-1315	-1873
4	MICOUT	-1195	-1873
5	AGC	-1075	-1873
6	ADIP	-955	-1873
7	AUTO_OPT	-835	-1873
8	AVDD	-725	-1873
9	BEEP_OPT	-614	-1873
10	ROSC	-492	-1873
11	VSS	-372	-1873
12	EDGE_OPT	-242	-1873
13	VDD	-132	-1873
14	KEY_OPT	-22	-1873
15	TEST	108	-1873
16	PLAY_BUSY	228	-1873
17	REC_BUSY	348	-1873
18	PLAY0	468	-1873
19	PLAY1	588	-1873
20	REC0	708	-1873
21	REC1	828	-1873
22	PVDD	948	-1873
23	AUDP	1218	-1865
24	AUDN	1515	-1625
25	PVSS	1521	-1208

## 8. DISCLAIMER

The information appearing in this publication is believed to be accurate.

Integrated circuits sold by Generalplus Technology are covered by the warranty and patent indemnification provisions stipulated in the terms of sale only. GENERALPLUS makes no warranty, express, statutory implied or by description regarding the information in this publication or regarding the freedom of the described chip(s) from patent infringement. FURTHERMORE, GENERALPLUS MAKES NO WARRANTY OF MERCHANTABILITY OR FITNESS FOR ANY PURPOSE. GENERALPLUS reserves the right to halt production or alter the specifications and prices at any time without notice. Accordingly, the reader is cautioned to verify that the data sheets and other information in this publication are current before placing orders. Products described herein are intended for use in normal commercial applications. Applications involving unusual environmental or reliability requirements, e.g. military equipment or medical life support equipment, are specifically not recommended without additional processing by GENERALPLUS for such applications. Please note that application circuits illustrated in this document are for reference purposes only.

9. REVISION HISTORY

Date	Revision #	Description	Page
MAR. 03, 2005	1.1	Remove Chip Size	9
JUN. 07, 2004	1.0	Original Note: The GPCR20A data sheet v1.0 is a continued version of SPCR20A data sheet v0.3.	12