

ASMT-CA00

AllnGaP Amber, 0.4mm Low Profile
Right Angle Surface Mount ChipLED



Data Sheet

Description

The ASMT-CA00 of amber color chip-type LEDs is designed with the smallest footprint to achieve high density of components on board. They have the industry standard footprint 1.6 mm x 1.0 mm and a height of only 0.4 mm. This makes them very suitable for cellular phone and mobile equipment backlighting and indication application where space is a constraint. In order to facilitate automated pick and place operation, these ChipLEDs are shipped in conductive tape and reel, with 4000 units per reel. These part are compatible with IR soldering.

Features

- Small size right angle mount
- 0603 industry standard footprint
- 0.4 mm low profile type
- Operating temperature range of -40°C to +85 °C
- Compatible with IR reflow soldering process
- Available in 8mm tape on 178mm (7") diameter reels
- Reel sealed in zip locked moisture barrier bags

Applications

- LCD Backlighting
- Keypad Side / Backlighting
- Pushbutton backlighting
- Symbol Indicator

Package Dimension

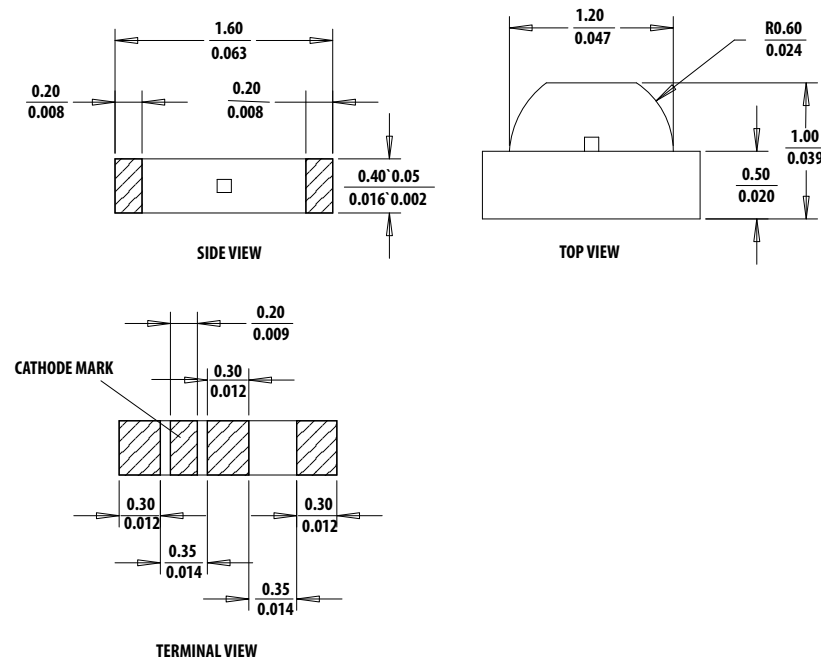

Notes:

1. All dimensions will be in millimeters (inches)
2. Tolerance is ± 0.1 mm (± 0.004 in) unless otherwise stated

CAUTION: ASMT-CA00 LEDs are Class 1A ESD sensitive per JESD22-A114C.01. Please observe appropriate precautions during handling and processing. Refer to Application Note AN-1142 for additional details.

Device Selection Guide

Package Dimension (mm)	Parts per Reel	Package Description
1.6 (L) x 1.0 (W) x 0.4 (H)	4000	Untinted, Non-diffused

Absolute Maximum Ratings at $T_A = 25^\circ\text{C}$

Parameter	ASMT-CA00	Unit
DC Forward Current ^[1]	25	mA
Power Dissipation	60	mW
Reverse Voltage ($I_R = 100\mu\text{A}$)	5	V
LED Junction Temperature	95	$^\circ\text{C}$
Operating Temperature Range	-40 to +85	$^\circ\text{C}$
Storage Temperature Range	-40 to +85	$^\circ\text{C}$
Soldering Temperature	See reflow soldering profile (Figure 7 & 8)	

Note:

1. Derate linearly as shown in Figure 4.

Electrical Characteristics at $T_A = 25^\circ\text{C}$

Part Number	Forward Voltage V_F (Volts) ^[1] @ $I_F = 20\text{mA}$		Reverse Breakdown V_R (Volts) @ $I_R = 100\mu\text{A}$	Thermal Resistance $R\theta_{J-PIN}$ ($^\circ\text{C}/\text{W}$)
	Typ.	Max.	Min.	Typ.
ASMT-CA00	1.9	2.4	5	400

Notes:

1. V_F tolerance : $\pm 0.1\text{V}$

Optical Characteristics at $T_A = 25^\circ\text{C}$

Part Number	Luminous Intensity I_V ^[1] (mcd) @ 20mA		Peak Wavelength λ_{peak} (nm)	Dominant Wavelength λ_d ^[2] (nm)	Viewing Angle $2\theta_{1/2}$ ^[3] (Degrees)
	Min.	Typ.	Typ.	Typ.	Typ.
ASMT-CA00	28.5	90	595	592	150

Notes:

1. The luminous intensity I_V is measured at the peak of the spatial radiation pattern which may not be aligned with the mechanical axis of the LED package.
2. The dominant wavelength, λ_d , is derived from the CIE Chromaticity Diagram and represents the perceived color of the device.
3. $\theta_{1/2}$ is the off-axis angle where the luminous intensity is $1/2$ the peak intensity.

Light Intensity (I_v) Bin Limits

Bin ID	Intensity (mcd)	
	Minimum	Maximum
N	28.50	45.00
P	45.00	71.50
Q	71.50	112.50
R	112.50	180.00

Tolerance : ±15%

Notes:

1. Bin categories are established for classification of products. Products may not be available in all categories. Please contact your Avago representative for information on current available bins.
2. The I_v binning specification set-up is for lowest allowable I_v binning only. There is no upper I_v bin limits.

Color Bin Limits

Bin ID	Dominant Wavelength (nm)	
	Minimum	Maximum
A	582.0	584.5
B	584.5	587.0
C	587.0	589.5
D	589.5	592.0
E	592.0	594.5

Tolerance : ±1nm

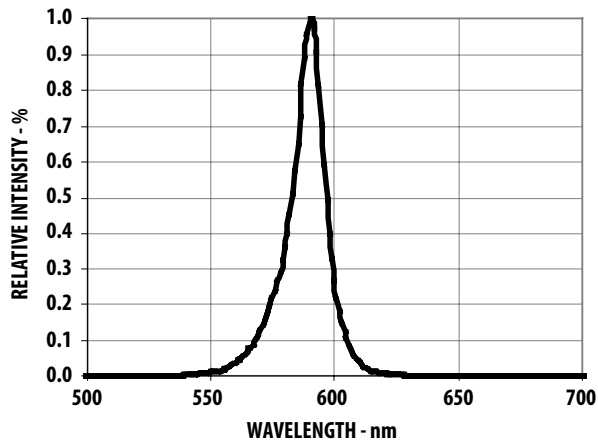

Figure 1. Relative intensity vs. wavelength

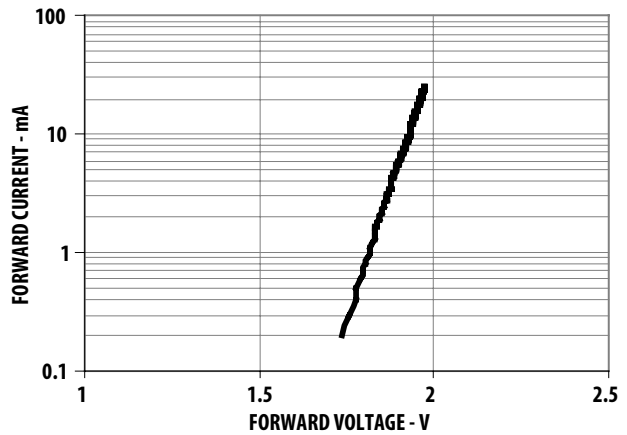

Figure 2. Forward current vs. forward voltage

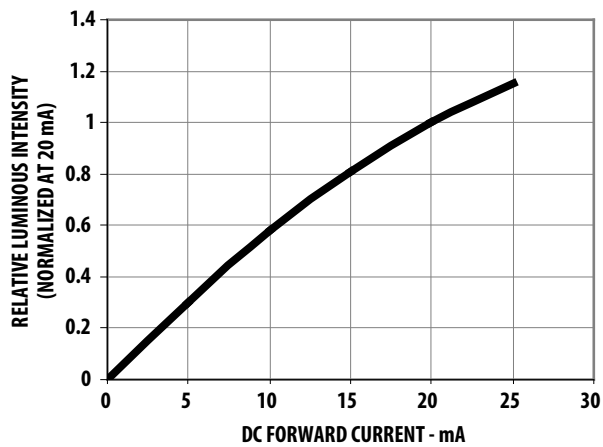

Figure 3. Luminous intensity vs. forward current

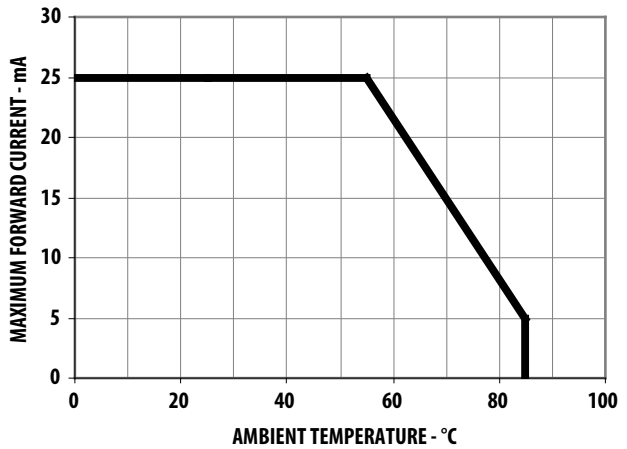
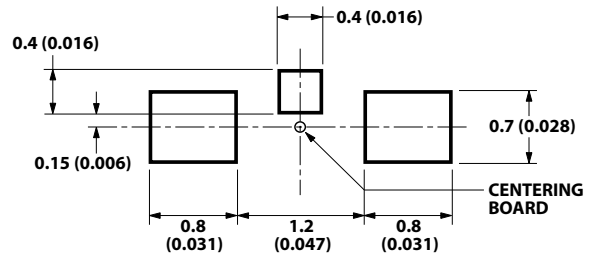

Figure 4. Maximum forward current vs. ambient temperature



Figure 5. Radiation pattern



- Notes:
 1. All dimensions are in millimeters (inches).
 2. Tolerance is $\pm 0.1\text{mm}$ ($\pm 0.004\text{in.}$) unless otherwise specified

Figure 6. Recommended soldering land pattern

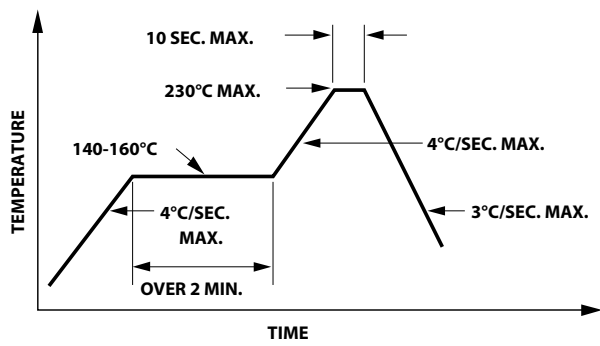

Figure 7. Recommended reflow soldering profile

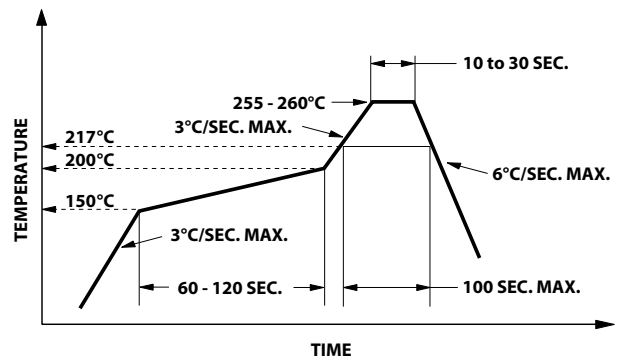

Figure 8. Recommended Pb-free reflow soldering profile

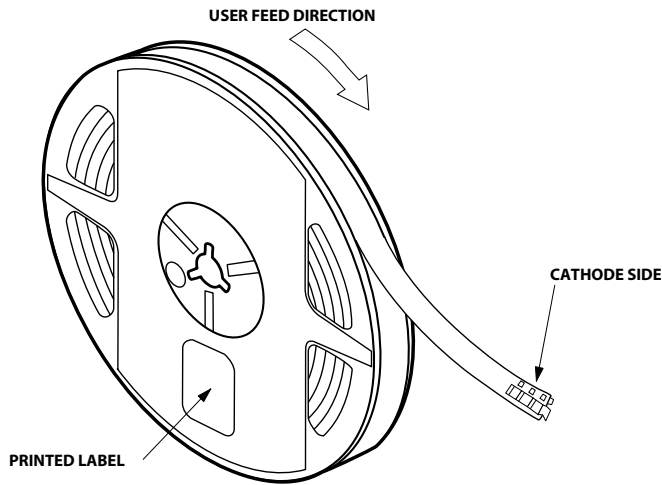

Figure 9. Reeling orientation

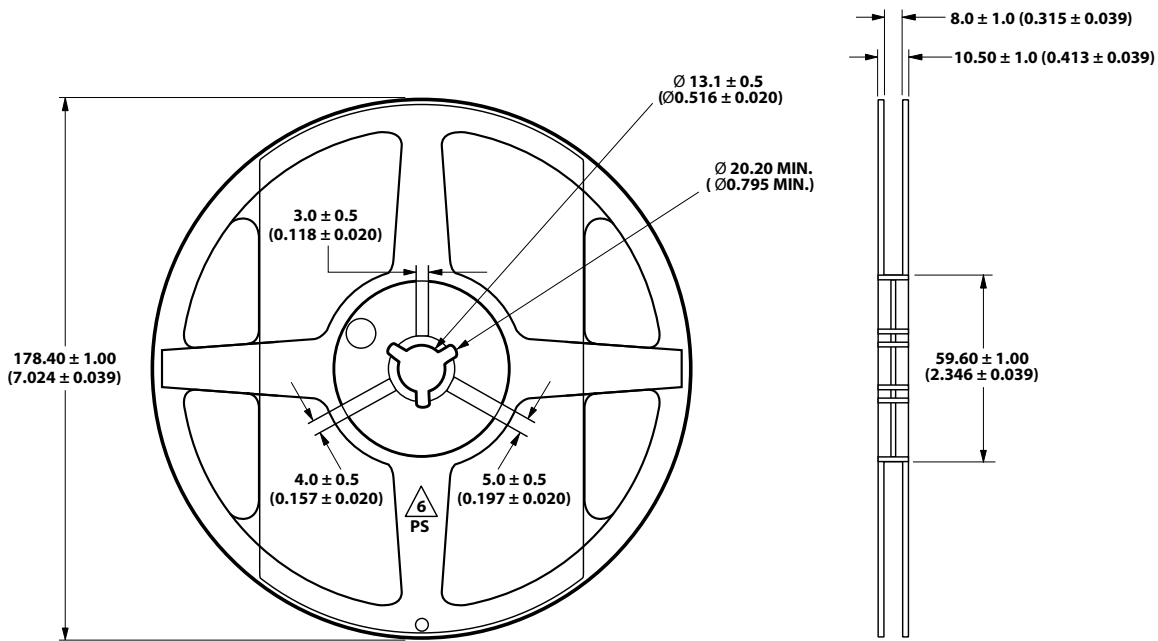

Figure 10. Reel dimensions

Notes:

1. All dimensions are in millimeters (inches).
2. Tolerance is $\pm 0.1\text{mm}$ ($\pm 0.004\text{in.}$) unless otherwise specified.

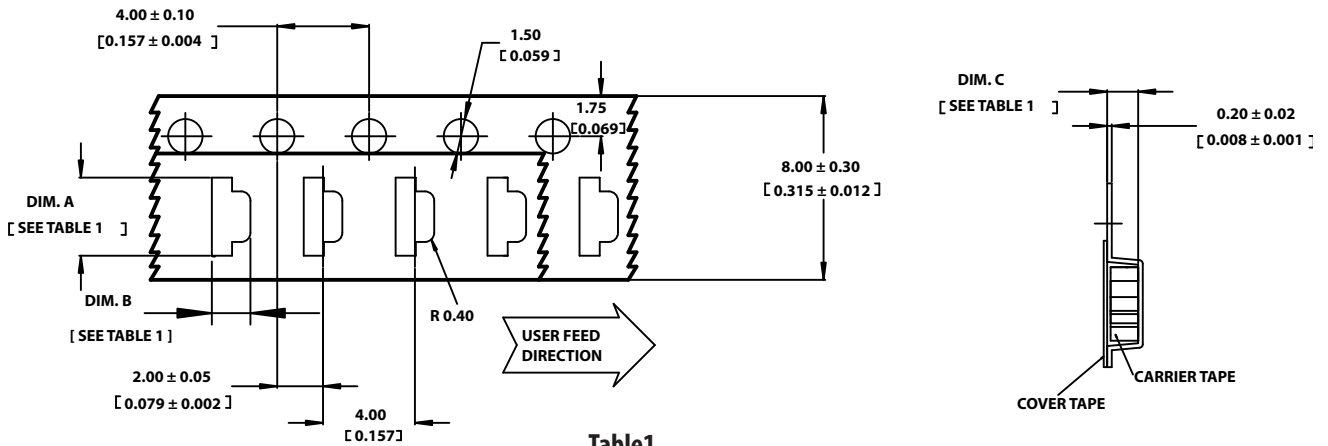

Table1.

PART NUMBER	DIM.A ± 0.10 (0.004)	DIM.B ± 0.10 (0.004)	DIM.C ± 0.10 (0.004)
ASMT-CA00	1.75 (0.069)	1.10 (0.043)	0.60 (0.024)

Dimensions In Millimeters (Inches)

Notes:

1. All dimensions are in millimeters (inches).
2. Tolerance is $\pm 0.1\text{mm}$ ($\pm 0.004\text{in.}$) unless otherwise specified.

Figure 11. Tape dimensions

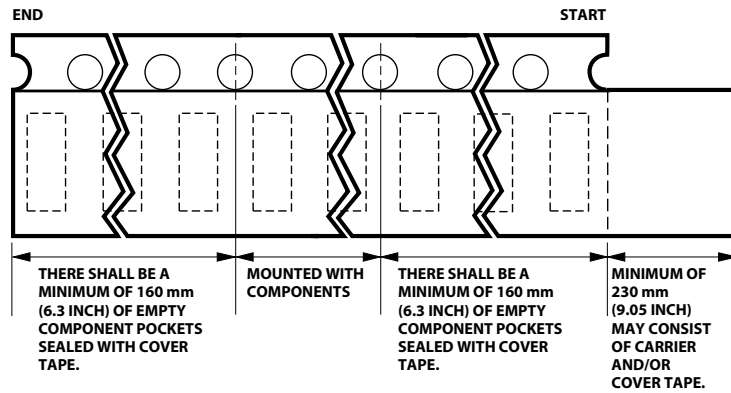

Figure 12. Tape leader and trailer dimensions

Reflow Soldering

For more information on reflow soldering, refer to Application Note AN-1060, Surface Mounting SMT LED Indicator Components.

Storage Condition

5 to 30°C @ 60%RH max. Baking is required before mounting, if

1. Humidity Indicator Card is > 10% when read at $23 \pm 5^\circ\text{C}$.
2. Device expose to factory conditions $30^\circ\text{C}/60\%\text{RH}$ more than 672 hours.

Recommended baking condition: $60 \pm 5^\circ\text{C}$ for 20 hours.

For product information and a complete list of distributors, please go to our web site: www.avagotech.com

Avago, Avago Technologies, and the A logo are trademarks of Avago Technologies in the United States and other countries. Data subject to change. Copyright © 2005-2010 Avago Technologies. All rights reserved. AV02-0586EN - May 7, 2010

Avago
TECHNOLOGIES