

**Pb Free Plating Product**

MBRB20H100CT/MBRB20H150CT/MBRB20H200CT



20.0 Ampere Surface Mount Dual Common Cathode Schottky Barrier Rectifiers

**Features**

- ★ ThinkiSemi Planar HMBR Technology
- ★ Good Soft Recovery Characteristics
- ★ Ideally Suited for Automatic Assembly
- ★ Low Forward Voltage
- ★ High Surge Current Capability
- ★ Low Leakage Current

**Applications**

- ★ Freewheeling, Snubber, Clamp
- ★ Inversion Welder
- ★ PFC
- ★ Plating Power Supply
- ★ Ultrasonic Cleaner and Welder
- ★ Converter & Chopper
- ★ UPS/LED SMPS/HID

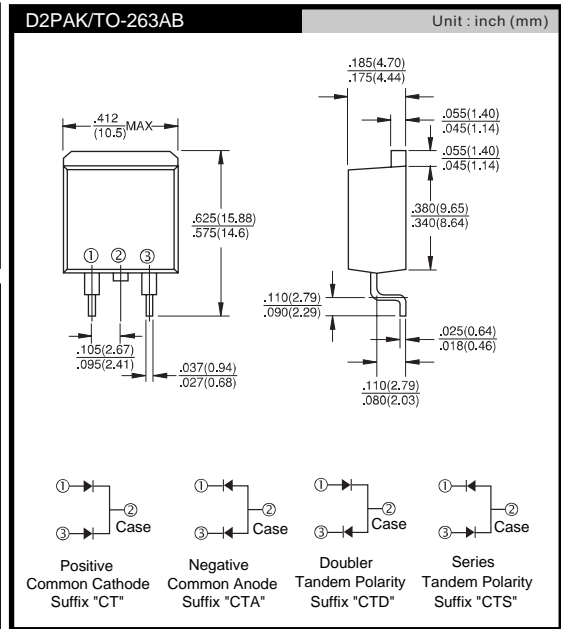

**MAXIMUM RATINGS AND ELECTRICAL CHARACTERISTICS (T<sub>A</sub>=25°C unless otherwise noted)**

PARAMETER	SYMBOL	MBRB20H100CT	MBRB20H150CT	MBRB20H200CT	Unit
Maximum repetitive peak reverse voltage	V <sub>RRM</sub>	100	150	200	V
Maximum RMS voltage	V <sub>RMS</sub>	70	105	140	V
Maximum DC blocking voltage	V <sub>DC</sub>	100	150	200	V
Maximum average forward rectified current	I <sub>F(AV)</sub>	20			A
Peak repetitive forward current (Rated VR, Square wave, 20KHz)	I <sub>FRM</sub>	20			A
Peak forward surge current, 8.3 ms single half sine-wave superimposed on rated load	I <sub>FSM</sub>	150			A
Peak repetitive reverse surge current (Note 1)	I <sub>RRM</sub>	1	0.5		A
Maximum instantaneous forward voltage (Note 2) I <sub>F</sub> =10A, T <sub>J</sub> =25°C I <sub>F</sub> =10A, T <sub>J</sub> =125°C I <sub>F</sub> =20A, T <sub>J</sub> =25°C I <sub>F</sub> =20A, T <sub>J</sub> =125°C	V <sub>F</sub>	0.85 0.75 0.95 0.85	0.88 0.75 0.97 0.85		V
Maximum reverse current @ rated V <sub>R</sub> T <sub>J</sub> =25°C T <sub>J</sub> =125°C	I <sub>R</sub>	5 2			μA mA
Voltage rate of change (Rated V <sub>R</sub> )	dV/dt	10000			V/μs
Typical thermal resistance	R <sub>θJC</sub>	1.5			°C/W
Operating junction temperature range	T <sub>J</sub>	- 55 to +175			°C
Storage temperature range	T <sub>STG</sub>	- 55 to +175			°C

Note 1: tp = 2.0 μs, 1.0KHz

Note 2: Pulse test with PW=300μs, 1% duty cycle

RATINGS AND CHARACTERISTICS CURVES

( $T_A=25^{\circ}\text{C}$  unless otherwise noted)

FIG. 1 FORWARD CURRENT DERATING CURVE

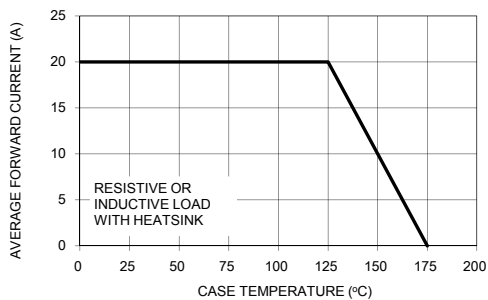

FIG. 2 MAXIMUM NON-REPETITIVE FORWARD SURGE CURRENT PER LEG

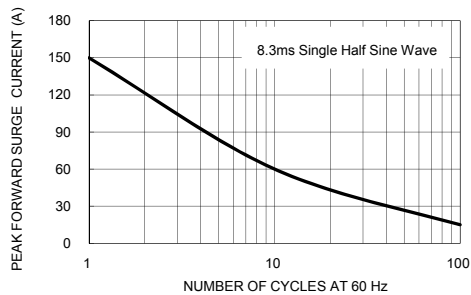

FIG. 3 TYPICAL FORWARD CHARACTERISTICS PER LEG

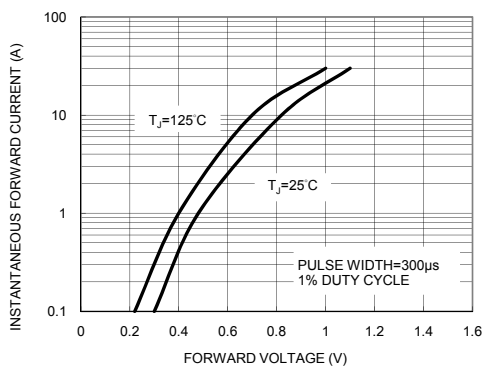

FIG. 4 TYPICAL REVERSE CHARACTERISTICS PER LEG

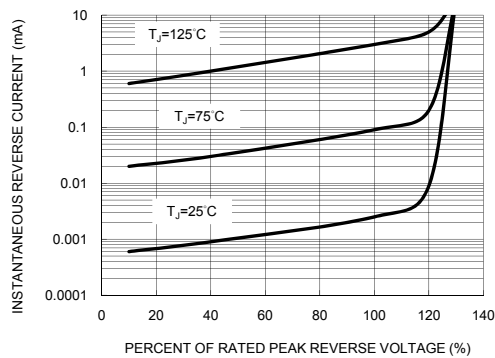

FIG. 5 TYPICAL JUNCTION CAPACITANCE

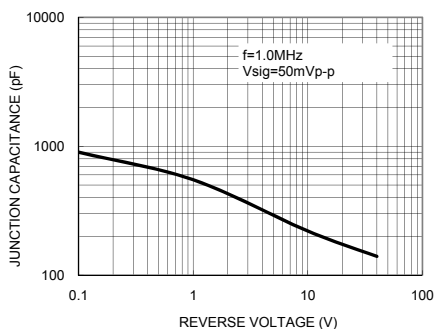

FIG. 6 TYPICAL TRANSIENT THERMAL IMPEDANCE PER LEG

