

Features

- -8 dBm to +2 dBm Optical Input Range
- Low Equivalent Input Noise (EIN): 3.2 pA/rtHz
- Single +5 V Bias
- 29 dB Gain at 55 MHz; 34 dB Gain at 1000 MHz
- 27 dB Gain Control Range
- +24 dBmV/ch Output at 550 MHz
- Lead-Free 4 mm PQFN-24LD Plastic Package
- Halogen-Free "Green" Mold Compound
- RoHS* Compliant and 260°C Reflow Compatible

Description

The MAAM-010333 provides high gain, low noise and low distortion amplification for optical node applications.

The MAAM-010333 is fabricated using M/A-COM Technology Solutions' low noise GaAs pHEMT technology in a lead-free 4 mm 24-lead package. The amplifier requires a minimal number of off-chip components resulting in a highly integrated low cost solution.

Ordering Information ^{1,2}

Part Number	Package
MAAM-010333-TR1000	1000 Piece Reel
MAAM-010333-TR3000	3000 Piece Reel
MAAM-010333-001SMB	Sample Test Board

1. Reference Application Note M513 for reel size information.
2. All sample boards include 5 loose parts. Sample board is supplied with mounted photodiode.

* Restrictions on Hazardous Substances,
European Union Directive 2002/95/EC.

Functional Schematic

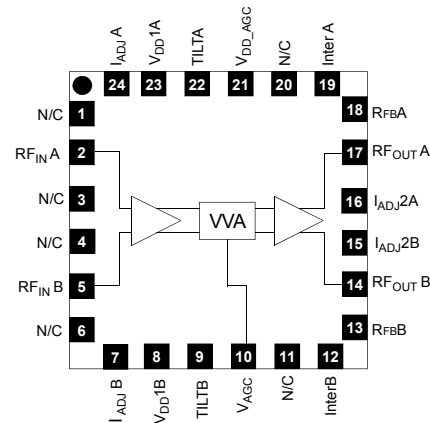

Pin Configuration ³

Pin No.	Pin Name	Description
1	N/C	No Connection
2	RF _{IN} A	RF Input A
3	N/C	No Connection
4	N/C	No Connection
5	RF _{IN} B	RF Input B
6	N/C	No Connection
7	I _{ADJ} B	Current Adjust
8	V _{DD} 1B	+ 5V Bias Voltage
9	TiltB	Tilt Connection
10	V _{AGC}	AGC Control Voltage: 0V to 3V
11	N/C	No Connection
12	InterB	Interstage Pin
13	R _{FB} B	Feedback Resistor
14	RF _{OUT} B	RF Output B
15	I _{ADJ} 2B	Current Adjust
16	I _{ADJ} 2A	Current Adjust
17	RF _{OUT} A	RF Output A
18	R _{FB} A	Feedback Resistor
19	InterA	Interstage Pin
20	N/C	No Connection
21	V _{DD} AGC	+ 5V AGC Bias Voltage
22	TiltA	Tilt Connection
23	V _{DD} 1A	+ 5V Bias Voltage
24	I _{ADJ} A	Current Adjust
25	Paddle	RF & DC Ground

3. The exposed pad centered on the package bottom must be connected to RF and DC ground.

Optical Node RF Amplifier 50 - 1200 MHz

Rev. V4

Electrical Specifications⁴: $V_{DD} = +5$ Volts, $T_A = 25^\circ\text{C}$, $Z_0 = 75 \Omega$

Parameter	Test Conditions	Units	Min.	Typ.	Max.
Trans-Impedance Gain ^{5,6}	50 MHz	dB	26.5	29.0	30.5
	870 MHz		31.0	33.0	35.0
	1 GHz		31.5	34.0	35.5
Gain Tilt ⁷	$V_{AGC} = +3$ V $V_{AGC} = 0$ V	dB	-	5 7	-
Gain Flatness ⁸	V_{AGC} : 0 to 3 V	dB		0.7	
Gain Control Range	50 MHz	dB	25.5	29.0	32.0
	870 MHz		23.0	26.0	29.0
	1 GHz		24.0	27.0	30.0
AGC Control Voltage Range	50 MHz - 1 GHz	V	0	-	+3
EIN ⁶	50 MHz - 1 GHz	pA/rHz	-	3.2	-
Output Return Loss	50 MHz - 1 GHz	dB	-	18	-
CTB ⁹	79 channels	dBc	-	-68	-
CSO ⁹	79 channels	dBc	-	-65	-
Current	$V_{DD} = +5$ V	mA	225	260	295

4. Performance is specified using JDSU Photodiode EPM-745 or equivalent (EPM705) and output balun # MABA-009210-CT1760.

5. $\text{Gain} = 20 \cdot \log(Z_T/75)$, where Z_T = Transconductance (Ω)

6. Specified at maximum gain ($V_{AGC} = +3.0$ V)

7. Positive gain slope from 50 MHz to 1 GHz (tilt of best fit straight line from 50 MHz to 1 GHz)

8. Flatness defined as peak-peak deviation from best fit straight line.

9. Optical Input Power Range: -8 dBm to +2 dBm; 79 channels

O_{MI} = 3.5%; P_{out} = +24 dBmV/ch at 550 MHz

P_{OUT} = +22.5 dBmV/ch at 55 MHz; +24 dBmV/ch at 550 MHz

Absolute Maximum Ratings^{10,11,12}

Parameter	Absolute Maximum
Input Power	+3 dBm Optical
Operating Voltage	+15 volts
AGC Voltage	+5 volts
Operating Temperature	-40°C to +85°C
Junction Temperature ¹³	+150°C
Storage Temperature	-65°C to +150°C

10. Exceeding any one or combination of these limits may cause permanent damage to this device.

11. M/A-COM Technology Solutions does not recommend sustained operation near these survivability limits.

12. Operating at nominal conditions with $T_J \leq +150^\circ\text{C}$ will ensure $\text{MTTF} > 1 \times 10^6$ hours.

13. Junction Temperature (T_J) = $T_C + \Theta_{jc} \cdot ((V \cdot I) - (P_{OUT} - P_{IN}))$
Typical thermal resistance (Θ_{jc}) = 19° C/W.

a) For $T_C = 25^\circ\text{C}$,

$T_J = 53^\circ\text{C}$ @ 5 V, 295 mA

b) For $T_C = 85^\circ\text{C}$,

$T_J = 112^\circ\text{C}$ @ 5 V, 295 mA

Handling Procedures

Please observe the following precautions to avoid damage:

Static Sensitivity

Gallium Arsenide Integrated Circuits are sensitive to electrostatic discharge (ESD) and can be damaged by static electricity. Proper ESD control techniques should be used when handling these devices.

Recommended PCB

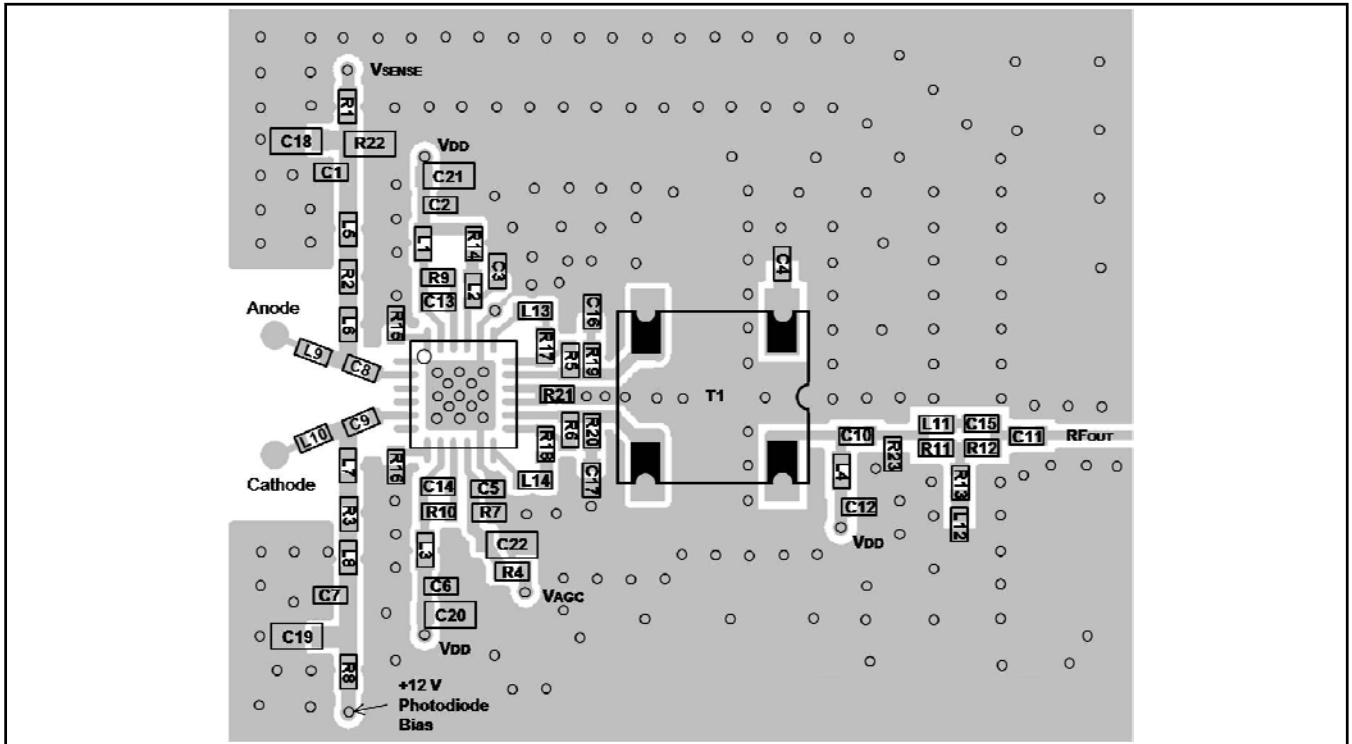

Schematic Including Off-Chip Components

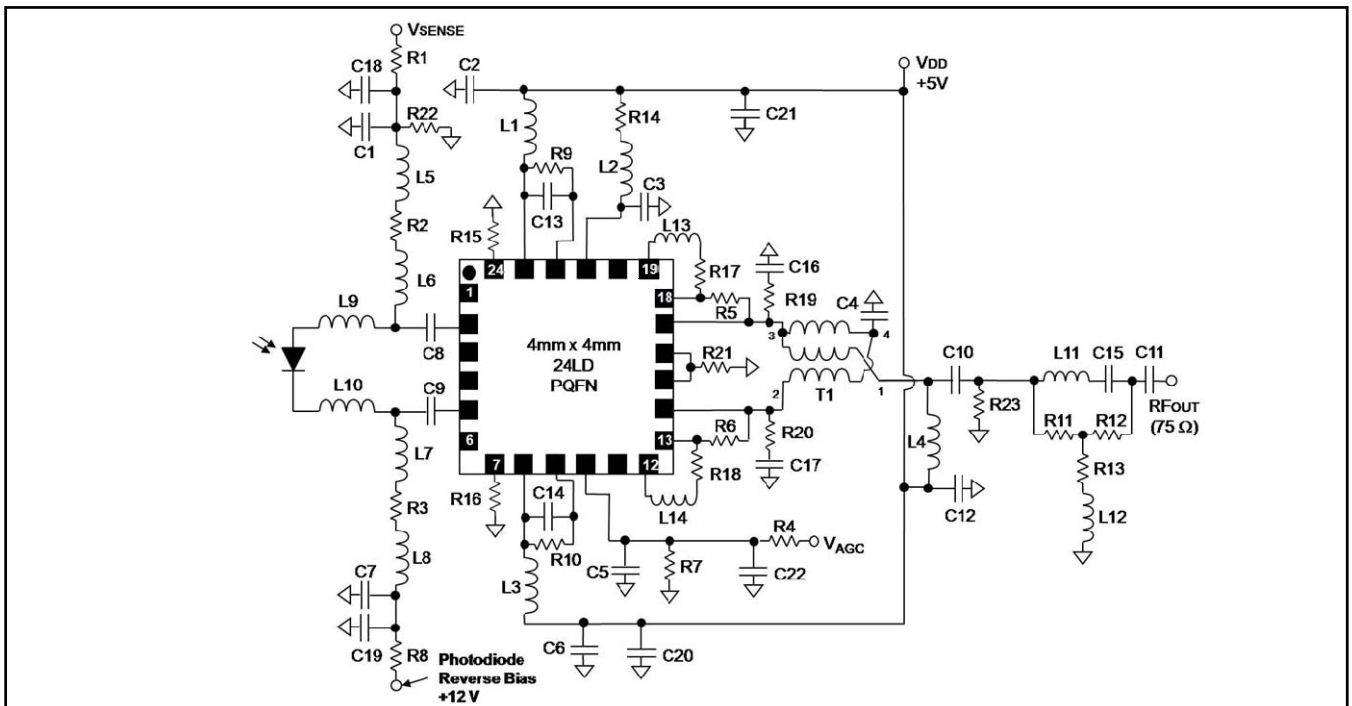

Parts List for 1GHz Matching

Component	Value	Case Style
L1 - L8 ¹⁴	Ferrite Bead	0402
L9 - L10	12 nH w/w	0402
L11	8.2 nH	0402
L12	33 nH	0402
L13 - L14	10 nH	0402
C1 - C12	10 nF	0402
C13 - C14	2.7 pF	0402
C15	3.0 pF	0402
C16 - C17	2.0 pF	0402
C18 - C22	1.0 μ F	0603
R1 - R4	1 k Ω	0402
R5 - R7	680 Ω	0402
R8	200 Ω	0402
R9 - R10	120 Ω	0402
R11 - R12	39 Ω	0402
R13	82 Ω	0402
R14	180 Ω	0402
R15 - R16	12 Ω	0402
R17 - R18	47 Ω	0402
R19 - R20	62 Ω	0402
R21	6.2 Ω	0402
R22	1 k Ω	0603
R23	470 Ω	0402
T1 ¹⁵	1:1 Balun	SM-118A

14. Ferrite Bead from Murata, part number BLM15HD182SN
15. M/A-COM Technology Solutions MABA-009210-CT1760
1:1 Tx Line Balun

Application Schematic

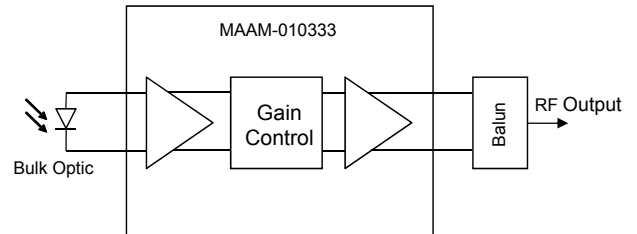

PCB Land Pattern

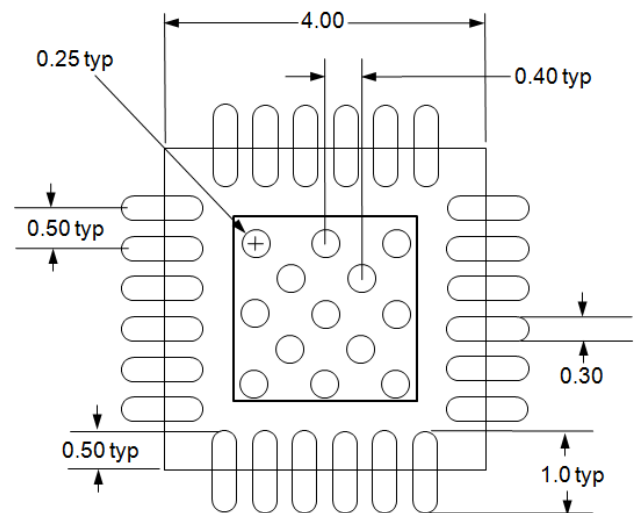

All dimension are in mm

Typical Performance Curves with 1GHz Matching:
+25°C, VAGC = 0V to 3V in 0.2 V Steps



Receiver Gain vs. Frequency to 1.1 GHz

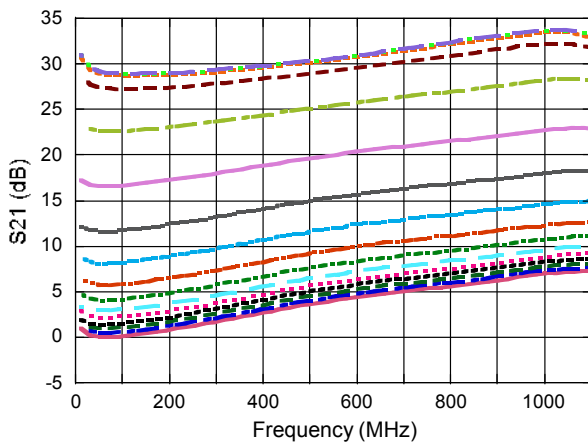

Receiver Gain vs. Frequency to 1.6 GHz

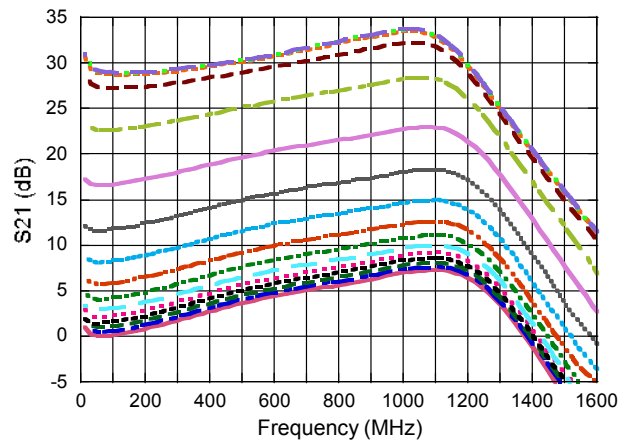

Output Return Loss vs. Frequency

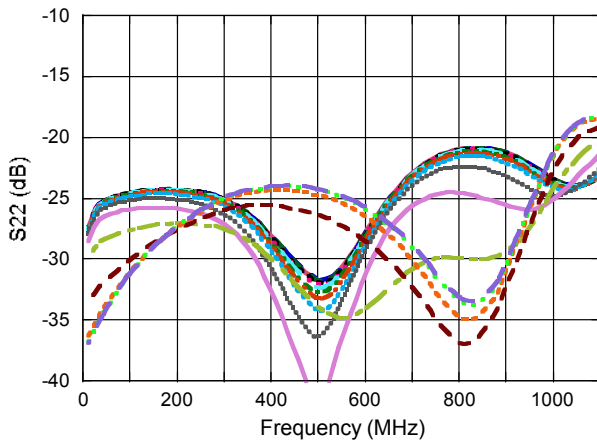

Typical Performance Curves with 1GHz Matching:
VAGC = 0V to 3V in 0.2 V Steps

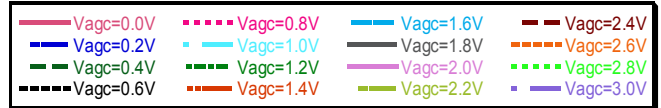

Gain Flatness Deviation From Best Fit Line
@ +25°C

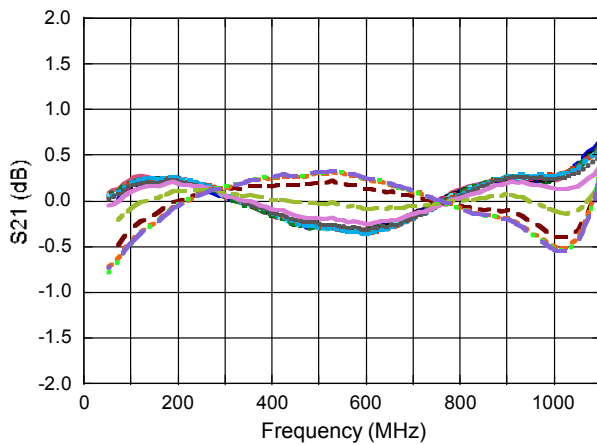

Gain Flatness Deviation From Best Fit Line
@ -40°C

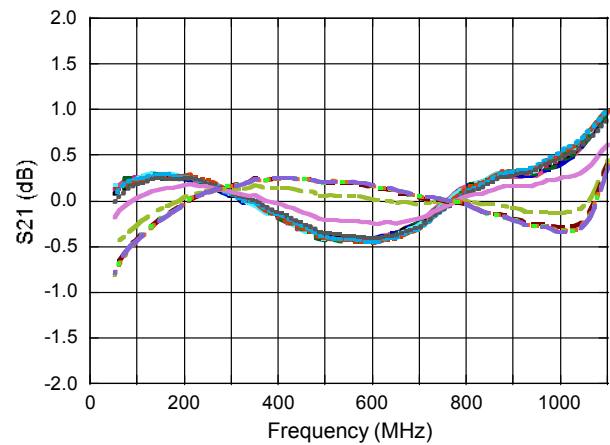

Gain Flatness Deviation From Best Fit Line
@ +85°C

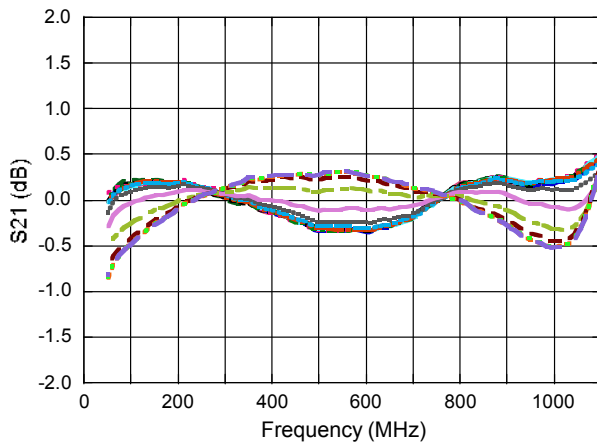

Typical Performance Curves with 1GHz Matching:

Gain Tilt Deviation from Average Tilt
VAGC: 0V to 3V in 0.2 V Steps

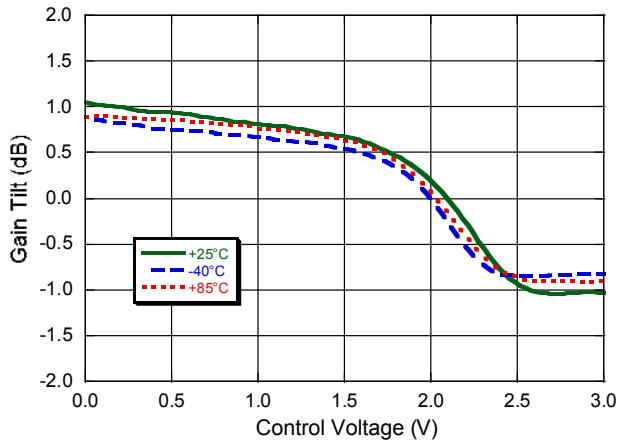

Equivalent Input Noise @ Max Gain
VAGC = 3V

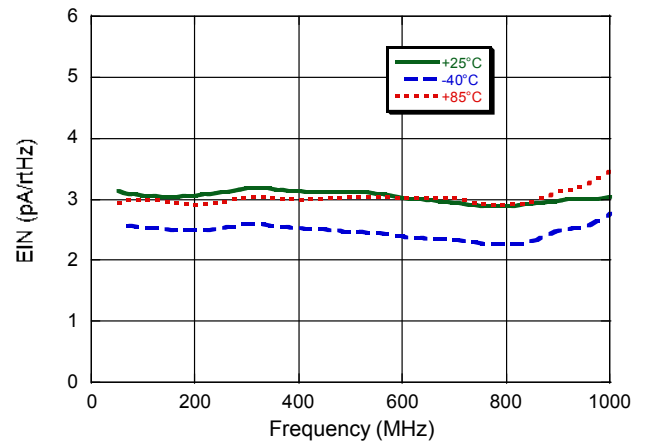

Receiver Gain vs. VAGC
VAGC = 0V to 3V in 0.2V Steps

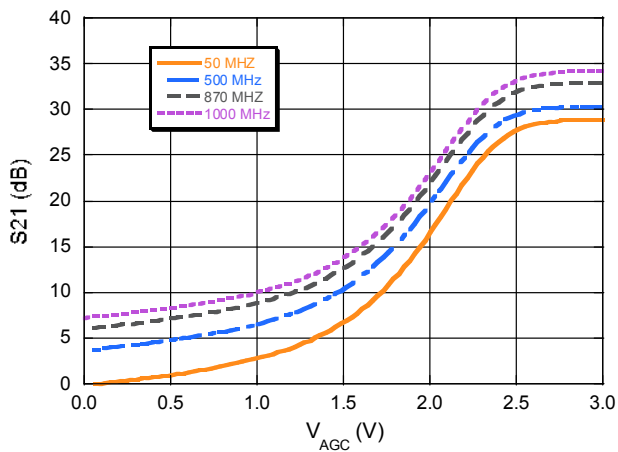

Typical Performance Curves with 1GHz Matching:

79 Channels; NTSC Frequency Plan Pout = +22.5 dBmV/ch @ 55 MHz; +24 dBmV @ 550 MHz

CTB vs. Optical Input Power

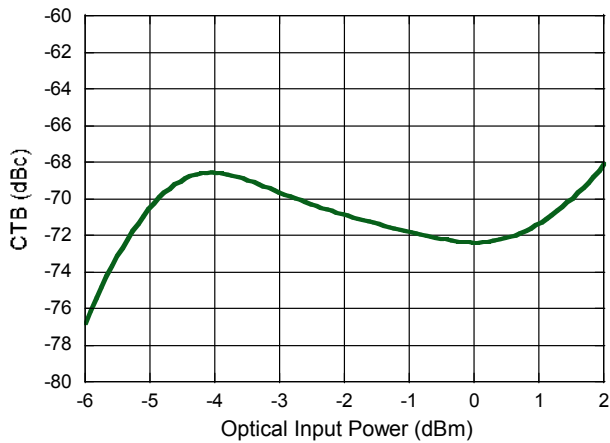

CSO_Lower vs. Optical Input Power

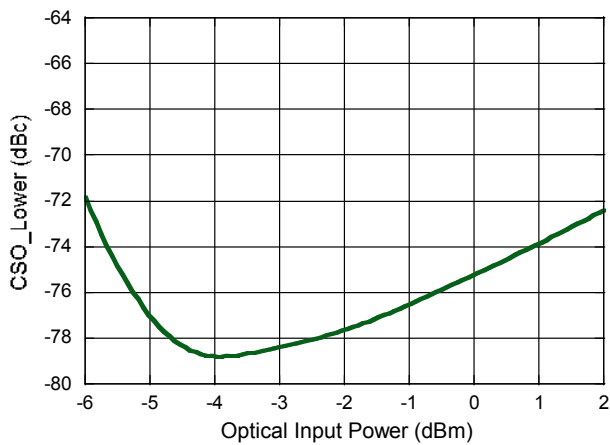

CSO_Upper vs. Optical Input Power

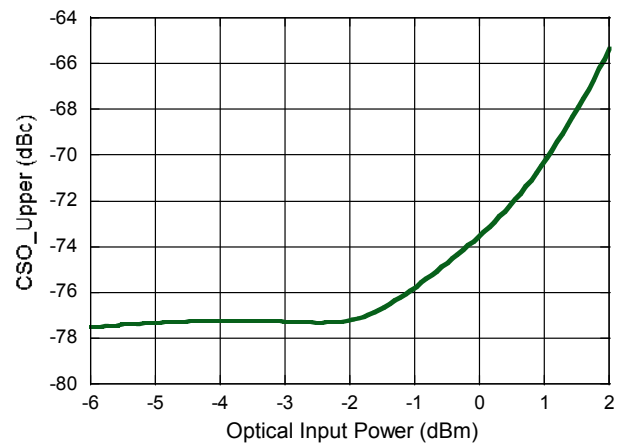

MAAM-010333



Optical Node RF Amplifier
50 - 1200 MHz

Rev. V4

Lead Free 4 mm 24-lead PQFN[†]

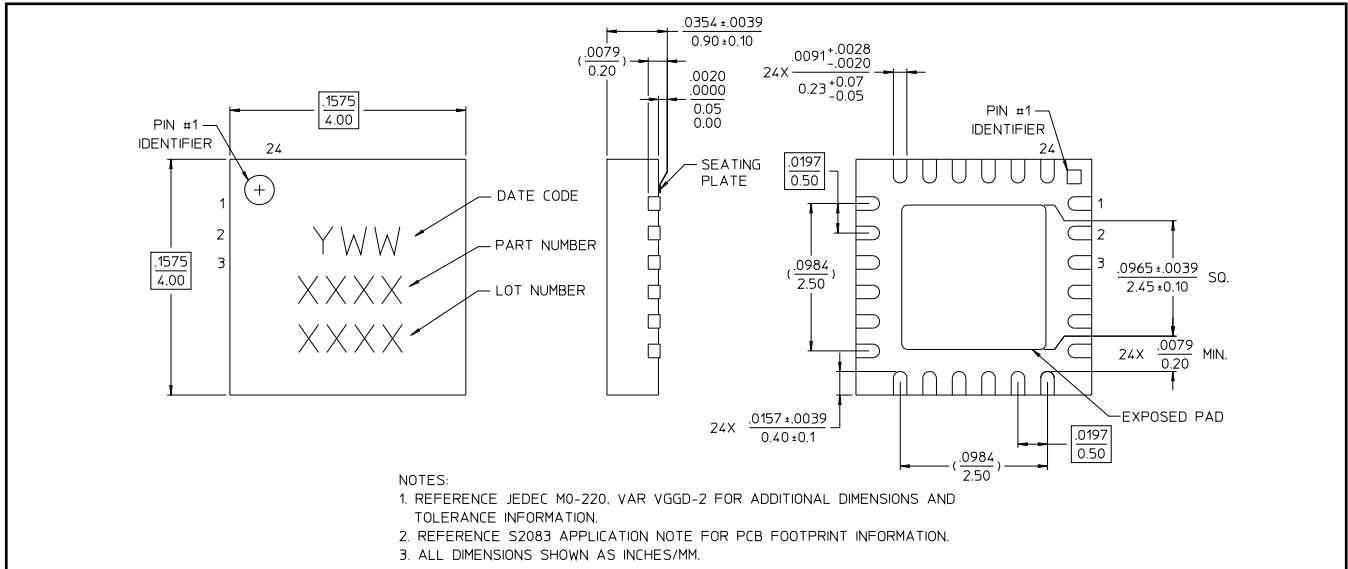

[†] Reference Application Note 2083 for lead-free solder reflow recommendations.
Meets JEDEC moisture sensitivity level 1 requirements.
Plating is 100% matte tin over copper.

MAAM-010333



Optical Node RF Amplifier
50 - 1200 MHz

Rev. V4

5V Application Section for 50MHz to 1200MHz

Parts List for 1.2GHz Matching

Component	Value	Case Style
L1 - L8 ¹⁶	Ferrite Bead	0402
L9 - L10	8.2 nH w/w	0402
L11	8.2 nH	0402
L12	33 nH	0402
L13 - L14	10 nH	0402
C1 - C12	10 nF	0402
C13 - C14	3.9 pF	0402
C15	3.0 pF	0402
C16 - C17	0.5 pF	0402
C18 - C22	1.0 μ F	0603
R1 - R4	1 k Ω	0402
R5 - R7	680 Ω	0402
R8	200 Ω	0402
R9 - R10	120 Ω	0402
R11 - R12	39 Ω	0402
R13	82 Ω	0402
R14	180 Ω	0402
R15 - R16	12 Ω	0402
R17 - R18	47 Ω	0402
R19 - R20	62 Ω	0402
R21	6.2 Ω	0402
R22	1 k Ω	0603
R23	Not Inserted	
T1 ¹⁷	1:1 Balun	SM-118A

16. Ferrite Bead from Murata, part number BLM15HD182SN

17. M/A-COM Technology Solutions MABA-009210-CT1760

1:1 T_x Line Balun

Application Schematic

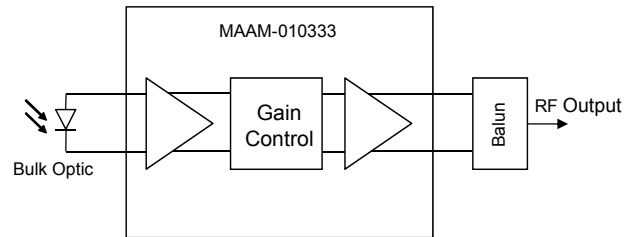

PCB Land Pattern

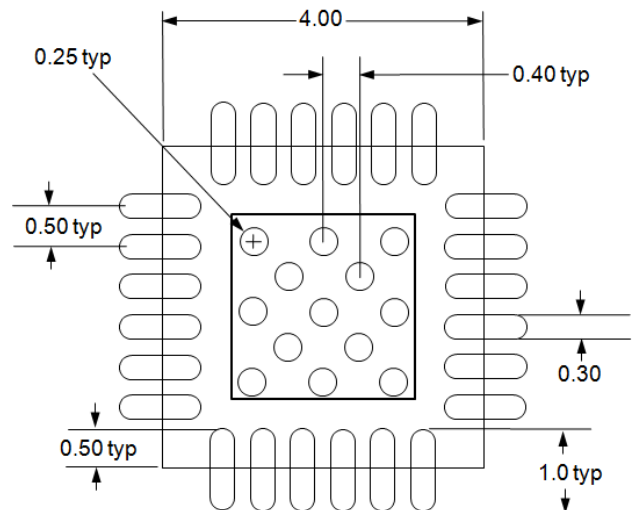

All dimension are in mm

5V Application Section for 50MHz to 1200MHz

Typical Performance Curves with 1.2GHz Matching:

+25°C, VAGC = 0V to 3V

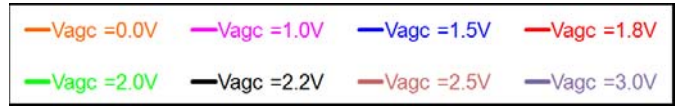

Receiver Gain vs. Frequency to 1.2 GHz

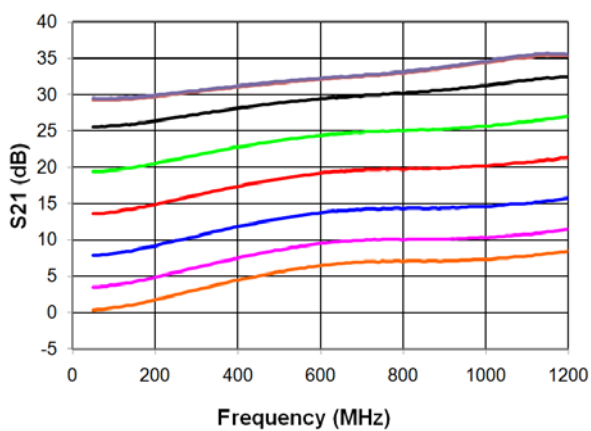

Gain Flatness Deviation From Best Fit Line

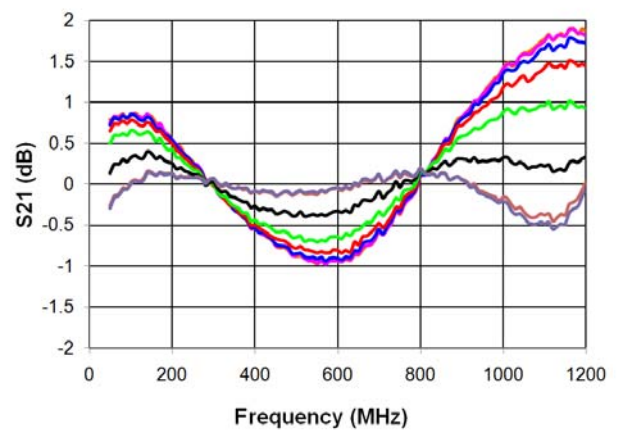

Output Return Loss vs. Frequency

