

20 V, 2 A Source Measure Unit

NI PXI-4130 **NEW!**

SMU Channel

- ± 20 V, 2 A, isolated
- 4-quadrant operation – 10 W sinking
- Remote sense capability
- 5 current ranges – 2 A to 200 μ A
- 1 nA measurement resolution on the 200 μ A range

Utility Channel

- 6 V, 1 A, ground referenced
- 120 μ V/20 μ A setpoint resolution
- 16-bit voltage/current setpoint and measurement

Operating Systems

- Windows Vista/XP/2000

Recommended Software

- LabVIEW
- LabVIEW Real-Time
- LabWindows™/CVI
- Measurement Studio

Other Compatible Software

- Microsoft Visual Basic
- C/C++

Driver Software (included)

- NI-DCPower



Overview

The NI PXI-4130 is a programmable, high-power source measure unit (SMU) in a single-slot, 3U PXI module. It has a single isolated SMU channel that offers a four-quadrant ± 20 V output that incorporates remote (4-wire) sense. This channel is capable of sourcing up to 40 W in quadrants I and III and sinking up to 10 W in quadrants II and IV. With five current ranges providing measurement resolution down to 1 nA, this precision source is ideal for design validation and semiconductor test applications that require programmatic sourcing and sweeping as well as high-accuracy measurements.

The PXI-4130 also includes a utility channel that can source either current or voltage with 16-bit setpoint and measurement resolution. You can use this output, which provides up to 6 V and 1 A, as a complementary power source to the SMU channel. Applications such as transistor characterization that require accurately sourcing a constant current or voltage while sweeping another current or voltage can greatly benefit from the reduced complexity, footprint, and cost that this module offers.

Both channels of the PXI-4130 power SMU can act as either a constant voltage source or a constant current source, with a settable compliance limit for either mode. In addition, you can enable remote sense on the SMU channel to maximize voltage output/measurement accuracy at your device under test for high-precision applications.

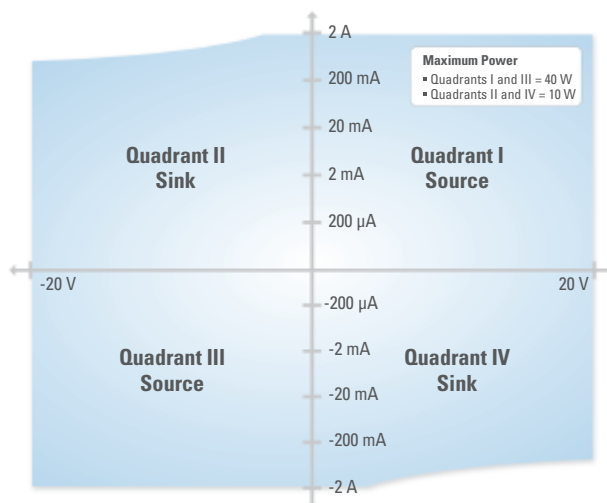

Figure 1. Channel 1 Quadrant Diagram (40 W in Quadrants I and III, 10 W in Quadrants II and IV)

Internal/External Supply Options

You can power the PXI-4130 either internally from the PXI backplane or externally through a front-panel-connected auxiliary DC supply such as the NI APS-4100. When internally powered, the ground-referenced, 0 to 6 V channel can be operated at its full 1 A current range, but the isolated SMU channel is limited to 300 mA or 2 W. When externally powered, the SMU channel can source up to 2 A at 20 V in addition to the utility channel, which sources up to 1 A at 6 V for a total maximum output power of 46 W.

20 V, 2 A Source Measure Unit

Software for Programmatic Control

NI-DCPower, an IVI-compliant instrument driver, offers complete programmatic control of the PXI-4130. You can use the NI-DCPower soft front panel to quickly troubleshoot or debug power supply operation. You can take advantage of the DCPower Express VI for an intuitive, configuration-based method of programming in the NI LabVIEW graphical development environment or the LabVIEW SignalExpress programming-free environment.

For low-level control of SMU hardware, the NI-DCPower instrument driver provides a complete API that exposes the full functionality of the hardware in an intuitive hierarchy. NI-DCPower also includes example programs that demonstrate concepts ranging from simple configuration to advanced sweeping and monitoring.

Extensive Protection Features

In addition to standard voltage and current limiting functionality, the PXI-4130 offers several other features to protect the supply and the load. The nonisolated output is protected against a reverse-polarity voltage application, and both outputs are protected against excessive voltages. Output fuses provide additional protection to prevent catastrophic failure as a last line of defense.

The operating voltage range for the auxiliary power input is 11 to 15.5 V. If the PXI-4130 detects voltages outside these limits, it shuts down until an input voltage within range is applied. If an input larger than 20 V is applied, the input crowbar protection turns on, protecting the input solid-state switching devices (and preregulator power supply) from overvoltage damage.

The PXI-4130 operates with only nominal temperature increases internally due to the intelligent digital power control of the output devices. If an overtemperature condition occurs in the PXI chassis due to fan failure or intake blockage, the output channels are shut down and a warning is issued. This type of condition requires user software intervention to reset, thus preventing the module from damage at excessive temperatures.

Ordering Information

NI PXI-4130	779647-30
Includes NI-DCPower and the DCPower Soft Front Panel.	
NI APS-4100	779671-01
NI PXI-4130, NI APS-4100 Bundle	779647-31

BUY NOW!

For complete product specifications, pricing, and accessory information, call 800 813 3693 (U.S.) or go to ni.com/modularinstruments.

20 V, 2 A Source Measure Unit

IV Characterization of Transistors

Because the PXI-4130 has two programmable output channels, you can use a single module to characterize metal-oxide semiconductor field-effect transistors (MOSFETs) and bipolar junction transistors (BJTs). Figure 2 shows the connections for performing IV curve tracing on a MOSFET using the PXI-4130. In this configuration, the utility channel is used to set a constant value for the gate-source voltage and the SMU channel is used to sweep the drain-source voltage and measure the induced current. You can also configure remote-sense connections on the SMU channel to precisely measure the drain-source voltage so that the IV curve data is as accurate as possible.

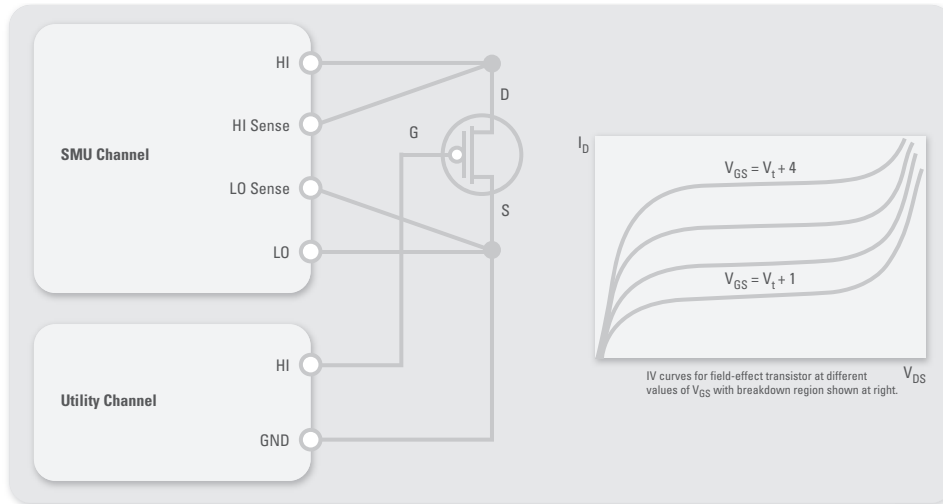

Figure 2. Connections for Performing IV Curve Tracing on a MOSFET Using the PXI-4130

Battery Charge-Cycle Testing and Rechargeable Source Simulation

The SMU channel on the PXI-4130 has the ability to sink up to 10 W of power, making it ideal for charge-cycle testing on rechargeable batteries. The configuration shown on the left side of Figure 3 illustrates the connections needed to charge and discharge a battery in either constant current or constant voltage mode. The remote-sense terminals precisely measure the voltage directly at the battery. Alternatively, you can use the PXI-4130 as a source simulator to test chargers or power other electronic devices. For rechargeable source simulation, replace the battery in Figure 3 with a charger or other device under test.

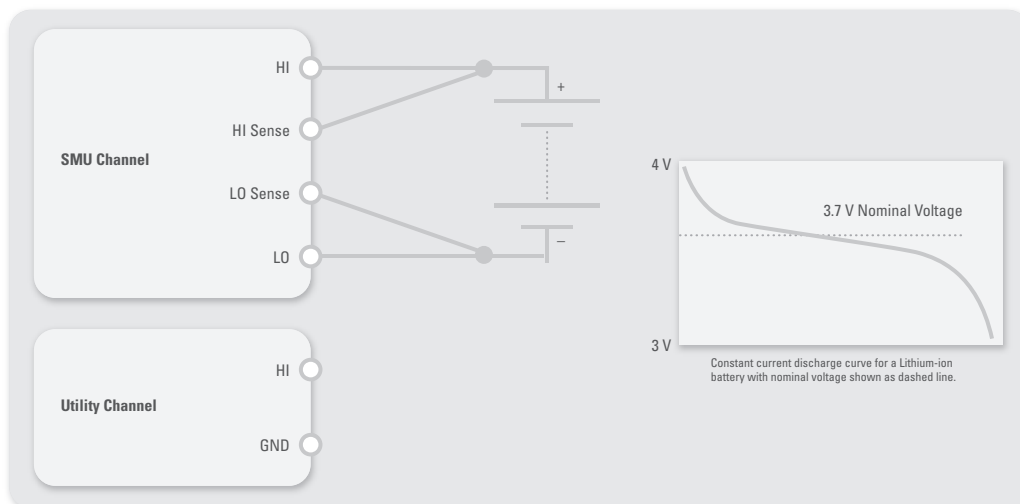

Figure 3. Connections for Charging and Discharging a Battery in Constant Current or Constant Voltage Mode Using the PXI-4130

20 V, 2 A Source Measure Unit

Specifications

>> For complete specifications, see the *NI PXI-4130 Specifications* at ni.com/manuals.

SMU Channel Specifications (Channel 1)

Voltage Programming Accuracy/Resolution

Range	Resolution	Accuracy ± (% of output + offset)
		1 Year, 23 °C ± 5 °C
±20 V	0.33 mV	0.034% + 1.8 mV
±6 V	0.1 mV	0.034% + 1.5 mV

Current Programming Accuracy/Resolution

Range	Resolution	Accuracy ± (% of output + offset)
		1 Year, 23 °C ± 5 °C
200 µA	10 nA	0.03% + 0.1 µA
2 mA	100 nA	0.03% + 1 µA
20 mA	1 µA	0.03% + 10 µA
200 mA	10 µA	0.03% + 100 µA
2 A ¹	100 µA	0.12% + 1 mA

Voltage Measurement Accuracy/Resolution

Range	Resolution	Accuracy ± (% of reading + offset)
		1 Year, 23 °C ± 5 °C
±20 V	0.10 mV	0.03% + 1.5 mV
±6 V	0.10 mV	0.03% + 1.5 mV

Current Measurement Accuracy/Resolution

Range	Resolution	Accuracy ± (% of reading + offset)
		1 Year, 23 °C ± 5 °C
200 µA	1.0 nA	0.03% + 0.02 µA
2 mA	10 nA	0.03% + 0.2 µA
20 mA	0.1 µA	0.03% + 2 µA
200 mA	1 µA	0.03% + 40 µA
2 A ¹	10 µA	0.12% + 200 µA

Channel 1 Additional Specifications

Settling time ²	500 µs
Output capacitance	
Low setting	10 nF
High setting	6.8 µF
Slew rate	0.08 V/µs
Transient response (typical)	Recovers to <0.1% of voltage range within 200 µs after a change in load current from 10 to 90% of current range
RMS normal mode noise	15 mV _{pp} typical into resistive load; <5 mV RMS; 20 Hz to 20 MHz bandwidth
Remote sense	Up to 1 V drop per lead using internal power or ≥12 V auxiliary power supply; add 120 µV to accuracy specification per volt of lead drop
Load regulation	
Voltage	20 mV per amp of output load using local sense

Current	0.01% of range per volt of output change
Line regulation (% of output + offset, per volt of change in auxiliary power input)	
Voltage	0.01 + 1 mV
Current	0.01 + 0.02% of range; temperature coefficient (Tempco) is 10% of accuracy specification per °C

Utility Channel Specifications (Channel 0)

Programming Accuracy/Resolution

Output Function	Range	Resolution	Accuracy ± (% of reading + offset)
			1 Year, 23 °C ± 10 °C
Voltage	+6 V	0.12 mV	0.05% + 4 mV
Current	1 A ¹	0.02 mA	0.15% + 4 mA

Measurement Accuracy/Resolution

Measurement Type	Range	Resolution	Accuracy ± (% of reading + offset)
			1 Year, 23 °C ± 10 °C
Voltage	+6 V	0.06 mV	0.05% + 4 mV
Current	1 A ¹	0.01 mA	0.15% + 4 mA

General Specifications

Programming and Measurement Timing³

Maximum output update rate	3000 updates/s
Maximum measurement rate	
(Samples to average = 1)	3 kS/s
Typical single point update latency	600 µs

Additional Information

Auxiliary power input protection	
Overvoltage	>15.5 VDC shut-off; >20 VDC crowbar (fused)
Overcurrent or reverse voltage	Fused
Recommended calibration interval	One year

¹See specifications for derating information.

²Settled to 1 percent, 1 V step, 50 percent of current range at final value; output capacitance set to low, using auxiliary power supply.

³Does not include load-dependent settling time.

20 V, 2 A Source Measure Unit

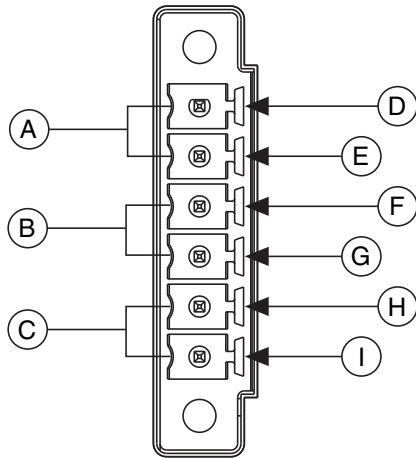

A Channel 0
 B Channel 1 Output
 C Channel 1 Sense
 D 0 to +6 V
 E GND
 F High Terminal
 G Low Terminal
 H Low Sense Terminal
 I High Sense Terminal

Figure 4. NI PXI-4130 Output Connector

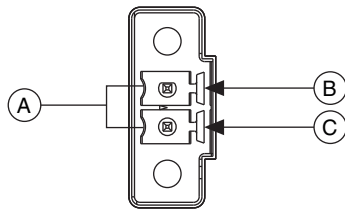

A Auxiliary Power Input
 B +11 to +15.5 V
 C GND

Figure 5. NI PXI-4130 Auxiliary Power Input Connector

Physical Characteristics

Dimensions.....	3U, 1-slot, PXI/CompactPCI module; 2.0 by 13.0 by 21.6 cm (0.8 by 5.1 by 8.5 in.)
Weight.....	312 g (11 oz)
User-replaceable fuses	
Channel 0 (internally socketed).....	1 Littelfuse 045301.5 (F 1.5 A 125 V)
Auxiliary power input (front panel-mount).....	1, 5 x 20 mm glass fuse (T 6.3 A L 250 V)

Note: NI recommends Littelfuse 21806.3 for auxiliary power input fuse.

Front panel connectors	
Output channels.....	MINI-COMBICON, 3.81 mm (6 position)
Auxiliary power input.....	MINI-COMBICON, 3.5 mm (2 position)

Note: Front panel connectors can accept wire gauges from 16 to 28 AWG.

NI Services and Support



NI has the services and support to meet your needs around the globe and through the application life cycle – from planning and development through deployment and ongoing maintenance. We offer services and service levels to meet customer requirements in research, design, validation, and manufacturing. Visit ni.com/services.

Training and Certification

NI training is the fastest, most certain route to productivity with our products. NI training can shorten your learning curve, save development time, and reduce maintenance costs over the application life cycle. We schedule instructor-led courses in cities worldwide, or we can hold a course at your facility. We also offer a professional certification program that identifies individuals who have high levels of skill and knowledge on using NI products. Visit ni.com/training.

Professional Services

Our NI Professional Services team is composed of NI applications and systems engineers and a worldwide National Instruments Alliance Partner program of more than 600 independent consultants and

integrators. Services range from start-up assistance to turnkey system integration. Visit ni.com/alliance.



OEM Support

We offer design-in consulting and product integration assistance if you want to use our products for OEM applications. For information about special pricing and services for OEM customers, visit ni.com/oem.

Local Sales and Technical Support

In offices worldwide, our staff is local to the country, giving you access to engineers who speak your language. NI delivers industry-leading technical support through online knowledge bases, our applications engineers, and access to 14,000 measurement and automation professionals within NI Developer Exchange forums. Find immediate answers to your questions at ni.com/support.

We also offer service programs that provide automatic upgrades to your application development environment and higher levels of technical support. Visit ni.com/ssp.

Hardware Services

NI Factory Installation Services

NI Factory Installation Services (FIS) is the fastest and easiest way to use your PXI or PXI/SCXI combination systems right out of the box. Trained NI technicians install the software and hardware and configure the system to your specifications. NI extends the standard warranty by one year on hardware components (controllers, chassis, modules) purchased with FIS. To use FIS, simply configure your system online with ni.com/pxiadvisor.

Calibration Services

NI recognizes the need to maintain properly calibrated devices for high-accuracy measurements. We provide manual calibration procedures, services to recalibrate your products, and automated calibration software specifically designed for use by metrology laboratories. Visit ni.com/calibration.

Repair and Extended Warranty

NI provides complete repair services for our products. Express repair and advance replacement services are also available. We offer extended warranties to help you meet project life-cycle requirements. Visit ni.com/services.



ni.com • 800 813 3693

National Instruments • info@ni.com

©2008 National Instruments. All rights reserved. CVI, LabVIEW, Measurement Studio, National Instruments, National Instruments Alliance Partner, NI, ni.com, SCXI, and SignalExpress are trademarks of National Instruments. The mark LabWindows is used under a license from Microsoft Corporation. Windows is a registered trademark of Microsoft Corporation in the United States and other countries. Other product and company names listed are trademarks or trade names of their respective companies. A National Instruments Alliance Partner is a business entity independent from National Instruments and has no agency, partnership, or joint-venture relationship with National Instruments.



351508B-01

2008-9943-101-D