

SN54LVTH245A, SN74LVTH245A 3.3-V ABT OCTAL BUS TRANSCEIVERS WITH 3-STATE OUTPUTS

SCBS130T – MAY 1992 – REVISED SEPTEMBER 2003

- Support Mixed-Mode Signal Operation (5-V Input and Output Voltages With 3.3-V V_{CC})
- Typical V_{OLP} (Output Ground Bounce) <0.8 V at $V_{CC} = 3.3$ V, $T_A = 25^\circ\text{C}$
- Support Unregulated Battery Operation Down to 2.7 V
- I_{off} and Power-Up 3-State Support Hot Insertion
- Bus Hold on Data Inputs Eliminates the Need for External Pullup/Pulldown Resistors
- Latch-Up Performance Exceeds 500 mA Per JESD 17
- ESD Protection Exceeds JESD 22
 - 2000-V Human-Body Model (A114-A)
 - 200-V Machine Model (A115-A)

SN54LVTH245A . . . J OR W PACKAGE
SN74LVTH245A . . . DB, DW, NS,
OR PW PACKAGE
(TOP VIEW)

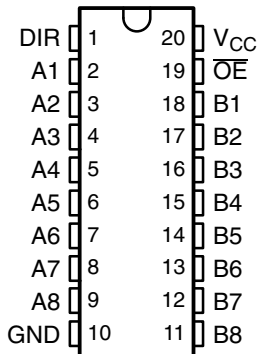

SN74LVTH245A . . . RGY PACKAGE
(TOP VIEW)

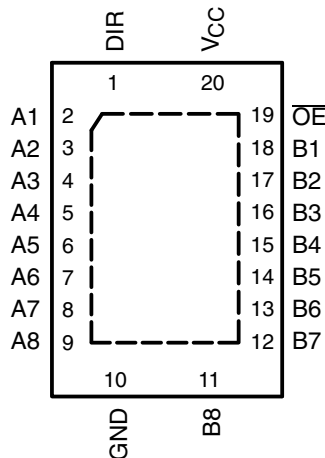

SN54LVTH245A . . . FK PACKAGE
(TOP VIEW)

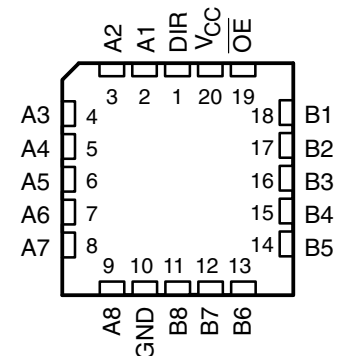

description/ordering information

These octal bus transceivers are designed specifically for low-voltage (3.3-V) V_{CC} operation, but with the capability to provide a TTL interface to a 5-V system environment.

ORDERING INFORMATION

| T_A | PACKAGE† | | ORDERABLE PART NUMBER | TOP-SIDE MARKING |
|----------------|---------------|------------------|-----------------------|------------------|
| -40°C to 85°C | QFN – RGY | Tape and reel | SN74LVTH245ARGYR | LXH245A |
| | SOIC – DW | Tube | SN74LVTH245ADW | LVTH245A |
| | | Tape and reel | SN74LVTH245ADWR | |
| | SOP – NS | Tape and reel | SN74LVTH245ANSR | LVTH245A |
| | SSOP – DB | Tape and reel | SN74LVTH245ADBR | LXH245A |
| | TSSOP – PW | Tube | SN74LVTH245APW | LXH245A |
| | | Tape and reel | SN74LVTH245APWR | |
| VFBGA – GQN | Tape and reel | SN74LVTH245AGQNR | LXH245A | |
| | | SN74LVTH245AZQNR | | |
| -55°C to 125°C | CDIP – J | Tube | SNJ54LVTH245AJ | SNJ54LVTH245AJ |
| | CFP – W | Tube | SNJ54LVTH245AW | SNJ54LVTH245AW |
| | LCCC – FK | Tube | SNJ54LVTH245AFK | SNJ54LVTH245AFK |

† Package drawings, standard packing quantities, thermal data, symbolization, and PCB design guidelines are available at www.ti.com/sc/package.



Please be aware that an important notice concerning availability, standard warranty, and use in critical applications of Texas Instruments semiconductor products and disclaimers thereto appears at the end of this data sheet.

PRODUCTION DATA information is current as of publication date. Products conform to specifications per the terms of Texas Instruments standard warranty. Production processing does not necessarily include testing of all parameters.

 **TEXAS
INSTRUMENTS**

POST OFFICE BOX 655303 • DALLAS, TEXAS 75265

Copyright © 2003, Texas Instruments Incorporated
On products compliant to MIL-PRF-38535, all parameters are tested unless otherwise noted. On all other products, production processing does not necessarily include testing of all parameters.

SN54LVTH245A, SN74LVTH245A 3.3-V ABT OCTAL BUS TRANSCEIVERS WITH 3-STATE OUTPUTS

SCBS130T – MAY 1992 – REVISED SEPTEMBER 2003

description/ordering information (continued)

These devices are designed for asynchronous communication between data buses. They transmit data from the A bus to the B bus or from the B bus to the A bus, depending on the logic level at the direction-control (DIR) input. The output-enable (\overline{OE}) input can be used to disable the devices so the buses are effectively isolated.

To ensure the high-impedance state during power up or power down, \overline{OE} should be tied to V_{CC} through a pullup resistor; the minimum value of the resistor is determined by the current-sinking capability of the driver.

Active bus-hold circuitry is provided to hold unused or floating data inputs at a valid logic level. Use of pullup or pulldown resistors with the bus-hold circuitry is not recommended.

These devices are fully specified for hot-insertion applications using I_{off} and power-up 3-state. The I_{off} circuitry disables the outputs, preventing damaging current backflow through the devices when they are powered down. The power-up 3-state circuitry places the outputs in the high-impedance state during power up and power down, which prevents driver conflict.

SN74LVTH245A . . . GQN OR ZQN PACKAGE (TOP VIEW)

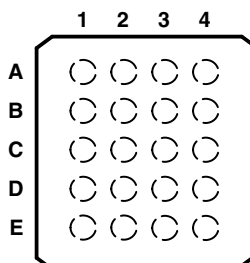

terminal assignments

| | 1 | 2 | 3 | 4 |
|---|-----|-----|----------|-----------------|
| A | A1 | DIR | V_{CC} | \overline{OE} |
| B | A3 | B2 | A2 | B1 |
| C | A5 | A4 | B4 | B3 |
| D | A7 | B6 | A6 | B5 |
| E | GND | A8 | B8 | B7 |

FUNCTION TABLE

| INPUTS | | OPERATION |
|-----------------|-----|-----------------|
| \overline{OE} | DIR | |
| L | L | B data to A bus |
| L | H | A data to B bus |
| H | X | Isolation |

logic diagram (positive logic)

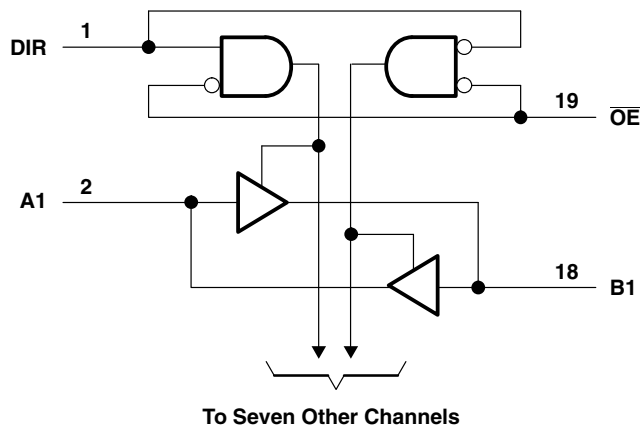

Pin numbers shown are for the DB, DW, FK, J, NS, PW, RGY, and W packages.

SN54LVTH245A, SN74LVTH245A 3.3-V ABT OCTAL BUS TRANSCEIVERS WITH 3-STATE OUTPUTS

SCBS130T – MAY 1992 – REVISED SEPTEMBER 2003

absolute maximum ratings over operating free-air temperature range (unless otherwise noted)†

| | |
|---|----------------------------|
| Supply voltage range, V_{CC} | –0.5 V to 4.6 V |
| Input voltage range, V_I (see Note 1) | –0.5 V to 7 V |
| Voltage range applied to any output in the high-impedance or power-off state, V_O (see Note 1) | –0.5 V to 7 V |
| Voltage range applied to any output in the high state, V_O (see Note 1) | –0.5 V to $V_{CC} + 0.5$ V |
| Current into any output in the low state, I_O : SN54LVTH245A | 96 mA |
| SN74LVTH245A | 128 mA |
| Current into any output in the high state, I_O (see Note 2): SN54LVTH245A | 48 mA |
| SN74LVTH245A | 64 mA |
| Input clamp current, I_{IK} ($V_I < 0$) | –50 mA |
| Output clamp current, I_{OK} ($V_O < 0$) | –50 mA |
| Package thermal impedance, θ_{JA} (see Note 3): DB package | 70°C/W |
| (see Note 3): DW package | 58°C/W |
| (see Note 3): GQN/ZQN package | 78°C/W |
| (see Note 3): NS package | 60°C/W |
| (see Note 3): PW package | 83°C/W |
| (see Note 4): RGY package | 37°C/W |
| Storage temperature range, T_{stg} | –65°C to 150°C |

† Stresses beyond those listed under “absolute maximum ratings” may cause permanent damage to the device. These are stress ratings only, and functional operation of the device at these or any other conditions beyond those indicated under “recommended operating conditions” is not implied. Exposure to absolute-maximum-rated conditions for extended periods may affect device reliability.

- NOTES: 1. The input and output negative-voltage ratings may be exceeded if the input and output clamp-current ratings are observed.
 2. This current flows only when the output is in the high state and $V_O > V_{CC}$.
 3. The package thermal impedance is calculated in accordance with JESD 51-7.
 4. The package thermal impedance is calculated in accordance with JESD 51-5.

recommended operating conditions (see Note 5)

| | | SN54LVTH245A | | SN74LVTH245A | | UNIT |
|--------------------------|------------------------------------|-----------------|-----|--------------|-----|------|
| | | MIN | MAX | MIN | MAX | |
| V_{CC} | Supply voltage | 2.7 | 3.6 | 2.7 | 3.6 | V |
| V_{IH} | High-level input voltage | 2 | | 2 | | V |
| V_{IL} | Low-level input voltage | | 0.8 | | 0.8 | V |
| V_I | Input voltage | | 5.5 | | 5.5 | V |
| I_{OH} | High-level output current | | –24 | | –32 | mA |
| I_{OL} | Low-level output current | | 48 | | 64 | mA |
| $\Delta t/\Delta v$ | Input transition rise or fall rate | Outputs enabled | | 10 | 10 | ns/V |
| $\Delta t/\Delta V_{CC}$ | Power-up ramp rate | 200 | | 200 | | μs/V |
| T_A | Operating free-air temperature | –55 | 125 | –40 | 85 | °C |

NOTE 5: All unused control inputs of the device must be held at V_{CC} or GND to ensure proper device operation. Refer to the TI application report, *Implications of Slow or Floating CMOS Inputs*, literature number SCBA004.



SN54LVTH245A, SN74LVTH245A

3.3-V ABT OCTAL BUS TRANSCEIVERS

WITH 3-STATE OUTPUTS

SCBS130T – MAY 1992 – REVISED SEPTEMBER 2003

electrical characteristics over recommended operating free-air temperature range (unless otherwise noted)

| PARAMETER | TEST CONDITIONS | | SN54LVTH245A | | SN74LVTH245A | | UNIT |
|-----------------------------|---|---|--------------|------|--------------|-----|---------------|
| | | | MIN | TYP† | MAX | MIN | |
| V_{IK} | $V_{CC} = 2.7\text{ V}$, $I_I = -18\text{ mA}$ | | -1.2 | | -1.2 | | V |
| V_{OH} | $V_{CC} = 2.7\text{ V to }3.6\text{ V}$, $I_{OH} = -100\text{ }\mu\text{A}$ | | $V_{CC}-0.2$ | | $V_{CC}-0.2$ | | V |
| | $V_{CC} = 2.7\text{ V}$, $I_{OH} = -8\text{ mA}$ | | 2.4 | | 2.4 | | |
| | $V_{CC} = 3\text{ V}$ | $I_{OH} = -24\text{ mA}$ | 2 | | 2 | | |
| V_{OL} | $V_{CC} = 2.7\text{ V}$ | $I_{OL} = 100\text{ }\mu\text{A}$ | 0.2 | | 0.2 | | V |
| | | $I_{OL} = 24\text{ mA}$ | 0.5 | | 0.5 | | |
| | $V_{CC} = 3\text{ V}$ | $I_{OL} = 16\text{ mA}$ | 0.4 | | 0.4 | | |
| | | $I_{OL} = 32\text{ mA}$ | 0.5 | | 0.5 | | |
| | | $I_{OL} = 48\text{ mA}$ | 0.55 | | 0.55 | | |
| I_I | Control inputs | $V_{CC} = 3.6\text{ V}$, $V_I = V_{CC}\text{ or GND}$ | ± 1 | | ± 1 | | μA |
| | | $V_{CC} = 0\text{ or }3.6\text{ V}$, $V_I = 5.5\text{ V}$ | 10 | | 10 | | |
| | A or B ports‡ | $V_{CC} = 3.6\text{ V}$, $V_I = 5.5\text{ V}$ | 20 | | 20 | | |
| | | $V_{CC} = 3.6\text{ V}$, $V_I = 0$ | -5 | | -5 | | |
| I_{off} | $V_{CC} = 0$, $V_I\text{ or }V_O = 0\text{ to }4.5\text{ V}$ | | | | ± 100 | | μA |
| $I_{I(\text{hold})}$ | A or B ports | $V_{CC} = 3\text{ V}$, $V_I = 0.8\text{ V}$ | 75 | | 75 | | μA |
| | | $V_{CC} = 3\text{ V}$, $V_I = 2\text{ V}$ | -75 | | -75 | | |
| | | $V_{CC} = 3.6\text{ V}^{\S}$, $V_I = 0\text{ to }3.6\text{ V}$ | | | 500 -750 | | |
| I_{OZPU} | $V_{CC} = 0\text{ to }1.5\text{ V}$, $V_O = 0.5\text{ V to }3\text{ V}$, $\overline{OE} = \text{don't care}$ | | $\pm 100^*$ | | ± 100 | | μA |
| I_{OZPD} | $V_{CC} = 1.5\text{ V to }0$, $V_O = 0.5\text{ V to }3\text{ V}$, $\overline{OE} = \text{don't care}$ | | $\pm 100^*$ | | ± 100 | | μA |
| I_{CC} | $V_{CC} = 3.6\text{ V}$, $I_O = 0$, $V_I = V_{CC}\text{ or GND}$ | Outputs high | 0.19 | | 0.19 | | mA |
| | | Outputs low | 5 | | 5 | | |
| | | Outputs disabled | 0.19 | | 0.19 | | |
| $\Delta I_{CC}^{\parallel}$ | $V_{CC} = 3\text{ V to }3.6\text{ V}$, One input at $V_{CC} - 0.6\text{ V}$, Other inputs at $V_{CC}\text{ or GND}$ | | 0.2 | | 0.2 | | mA |
| C_i | $V_I = 3\text{ V or }0$ | | 4 | | 4 | | pF |
| C_{io} | $V_O = 3\text{ V or }0$ | | 9 | | 9 | | pF |

* On products compliant to MIL-PRF-38535, this parameter is not production tested.

† All typical values are at $V_{CC} = 3.3\text{ V}$, $T_A = 25^\circ\text{C}$.

‡ Unused terminals are at $V_{CC}\text{ or GND}$.

§ This is the bus-hold maximum dynamic current. It is the minimum overdrive current required to switch the input from one state to another.

¶ This is the increase in supply current for each input that is at the specified TTL voltage level, rather than $V_{CC}\text{ or GND}$.



SN54LVTH245A, SN74LVTH245A 3.3-V ABT OCTAL BUS TRANSCEIVERS WITH 3-STATE OUTPUTS

SCBS130T – MAY 1992 – REVISED SEPTEMBER 2003

switching characteristics over recommended operating free-air temperature range, $C_L = 50$ pF (unless otherwise noted) (see Figure 1)

| PARAMETER | FROM (INPUT) | TO (OUTPUT) | SN54LVTH245A | | | | SN74LVTH245A | | | | UNIT | |
|-----------|-----------------|-------------|--|-----|-------------------------|-----|--|------|-----|-------------------------|------|-----|
| | | | $V_{CC} = 3.3\text{ V} \pm 0.3\text{ V}$ | | $V_{CC} = 2.7\text{ V}$ | | $V_{CC} = 3.3\text{ V} \pm 0.3\text{ V}$ | | | $V_{CC} = 2.7\text{ V}$ | | |
| | | | MIN | MAX | MIN | MAX | MIN | TYP† | MAX | MIN | | MAX |
| t_{PLH} | A or B | B or A | 0.7 | 3.7 | | 4.2 | 1.2 | 2.3 | 3.5 | | 4 | ns |
| t_{PHL} | | | 0.7 | 3.7 | | 4.2 | 1.2 | 2.1 | 3.5 | | 4 | |
| t_{PZH} | \overline{OE} | A or B | 1.2 | 5.7 | | 7.4 | 1.3 | 3.2 | 5.5 | | 7.1 | ns |
| t_{PZL} | | | 1.6 | 5.7 | | 6.8 | 1.7 | 3.4 | 5.5 | | 6.5 | |
| t_{PHZ} | \overline{OE} | A or B | 1.8 | 6.2 | | 6.8 | 2.2 | 3.5 | 5.9 | | 6.5 | ns |
| t_{PLZ} | | | 1.8 | 5.3 | | 5.5 | 2.2 | 3.4 | 5 | | 5.1 | |

† All typical values are at $V_{CC} = 3.3\text{ V}$, $T_A = 25^\circ\text{C}$.

SN54LVTH245A, SN74LVTH245A 3.3-V ABT OCTAL BUS TRANSCEIVERS WITH 3-STATE OUTPUTS

SCBS130T – MAY 1992 – REVISED SEPTEMBER 2003

PARAMETER MEASUREMENT INFORMATION

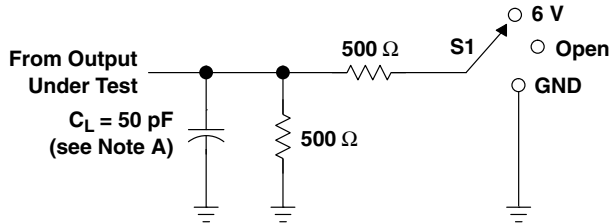

LOAD CIRCUIT

| TEST | S1 |
|-------------------|------|
| t_{PLH}/t_{PHL} | Open |
| t_{PLZ}/t_{PZL} | 6 V |
| t_{PHZ}/t_{PZH} | GND |

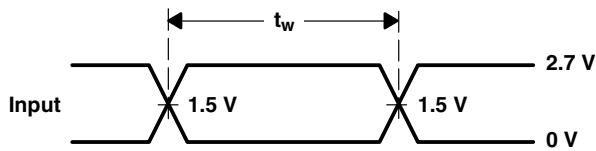

VOLTAGE WAVEFORMS
PULSE DURATION

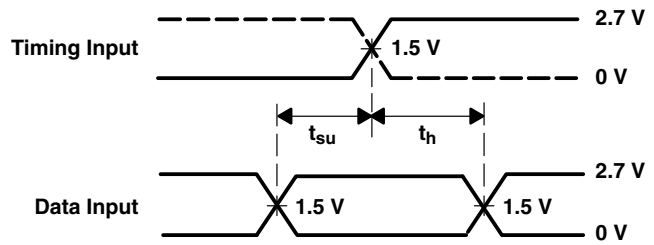

VOLTAGE WAVEFORMS
SETUP AND HOLD TIMES

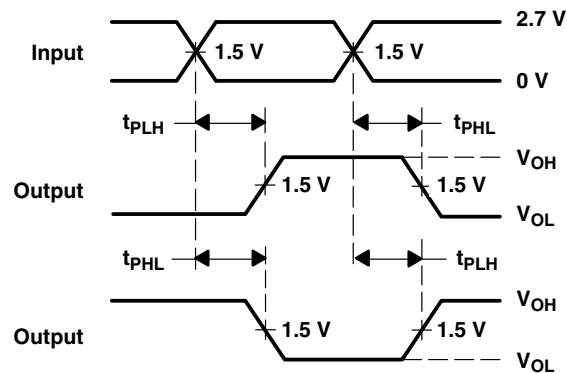

VOLTAGE WAVEFORMS
PROPAGATION DELAY TIMES
INVERTING AND NONINVERTING OUTPUTS

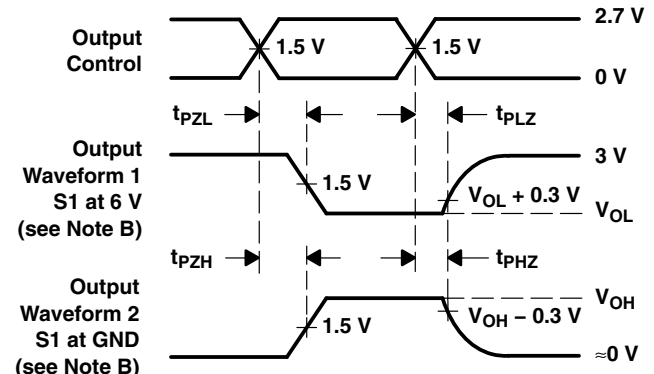

VOLTAGE WAVEFORMS
ENABLE AND DISABLE TIMES
LOW- AND HIGH-LEVEL ENABLING

- NOTES: A. C_L includes probe and jig capacitance.
 B. Waveform 1 is for an output with internal conditions such that the output is low except when disabled by the output control. Waveform 2 is for an output with internal conditions such that the output is high except when disabled by the output control.
 C. All input pulses are supplied by generators having the following characteristics: $PRR \leq 10 \text{ MHz}$, $Z_O = 50 \Omega$, $t_r \leq 2.5 \text{ ns}$, $t_f \leq 2.5 \text{ ns}$.
 D. The outputs are measured one at a time with one transition per measurement.
 E. All parameters and waveforms are not applicable to all devices.

Figure 1. Load Circuit and Voltage Waveforms

PACKAGING INFORMATION

| Orderable Device | Status (1) | Package Type | Package Drawing | Pins | Package Qty | Eco Plan (2) | Lead/Ball Finish (6) | MSL Peak Temp (3) | Op Temp (°C) | Device Marking (4/5) | Samples |
|-------------------|---------------|--------------|-----------------|------|-------------|-------------------------|-------------------------|----------------------|--------------|--|-------------------------|
| 5962-9564201Q2A | ACTIVE | LCCC | FK | 20 | 1 | TBD | POST-PLATE | N / A for Pkg Type | -55 to 125 | 5962-9564201Q2A SNJ54LVTH 245AFK | Samples |
| 5962-9564201QRA | ACTIVE | CDIP | J | 20 | 1 | TBD | A42 | N / A for Pkg Type | -55 to 125 | 5962-9564201QR A SNJ54LVTH245AJ | Samples |
| 5962-9564201QSA | ACTIVE | CFP | W | 20 | 1 | TBD | A42 | N / A for Pkg Type | -55 to 125 | 5962-9564201QS A SNJ54LVTH245AW | Samples |
| 5962-9564201V2A | ACTIVE | LCCC | FK | 20 | 1 | TBD | POST-PLATE | N / A for Pkg Type | -55 to 125 | 5962-9564201V2A SNV54LVTH 245AFK | Samples |
| 5962-9564201VRA | ACTIVE | CDIP | J | 20 | 1 | TBD | A42 | N / A for Pkg Type | -55 to 125 | 5962-9564201VR A SNV54LVTH245AJ | Samples |
| 5962-9564201VSA | ACTIVE | CFP | W | 20 | 1 | TBD | A42 | N / A for Pkg Type | -55 to 125 | 5962-9564201VS A SNV54LVTH245AW | Samples |
| SN74LVTH245ADBLE | OBSOLETE | SSOP | DB | 20 | | TBD | Call TI | Call TI | -40 to 85 | | |
| SN74LVTH245ADBR | ACTIVE | SSOP | DB | 20 | 2000 | Green (RoHS & no Sb/Br) | CU NIPDAU | Level-1-260C-UNLIM | -40 to 85 | LXH245A | Samples |
| SN74LVTH245ADBRG4 | ACTIVE | SSOP | DB | 20 | 2000 | Green (RoHS & no Sb/Br) | CU NIPDAU | Level-1-260C-UNLIM | -40 to 85 | LXH245A | Samples |
| SN74LVTH245ADW | ACTIVE | SOIC | DW | 20 | 25 | Green (RoHS & no Sb/Br) | CU NIPDAU | Level-1-260C-UNLIM | -40 to 85 | LVTH245A | Samples |
| SN74LVTH245ADWG4 | ACTIVE | SOIC | DW | 20 | 25 | Green (RoHS & no Sb/Br) | CU NIPDAU | Level-1-260C-UNLIM | -40 to 85 | LVTH245A | Samples |
| SN74LVTH245ADWR | ACTIVE | SOIC | DW | 20 | 2000 | Green (RoHS & no Sb/Br) | CU NIPDAU | Level-1-260C-UNLIM | -40 to 85 | LVTH245A | Samples |
| SN74LVTH245ADWRE4 | ACTIVE | SOIC | DW | 20 | 2000 | Green (RoHS & no Sb/Br) | CU NIPDAU | Level-1-260C-UNLIM | -40 to 85 | LVTH245A | Samples |
| SN74LVTH245ADWRG4 | ACTIVE | SOIC | DW | 20 | 2000 | Green (RoHS & no Sb/Br) | CU NIPDAU | Level-1-260C-UNLIM | -40 to 85 | LVTH245A | Samples |

| Orderable Device | Status (1) | Package Type | Package Drawing | Pins | Package Qty | Eco Plan (2) | Lead/Ball Finish (6) | MSL Peak Temp (3) | Op Temp (°C) | Device Marking (4/5) | Samples |
|-------------------|---------------|----------------------------|-----------------|------|-------------|----------------------------|-------------------------|----------------------|--------------|--|-------------------------|
| SN74LVTH245AGQNR | OBSOLETE | BGA MICROSTAR JUNIOR | GQN | 20 | | TBD | Call TI | Call TI | -40 to 85 | LXH245A | |
| SN74LVTH245ANSR | ACTIVE | SO | NS | 20 | 2000 | Green (RoHS & no Sb/Br) | CU NIPDAU | Level-1-260C-UNLIM | -40 to 85 | LVTH245A | Samples |
| SN74LVTH245ANSRG4 | ACTIVE | SO | NS | 20 | 2000 | Green (RoHS & no Sb/Br) | CU NIPDAU | Level-1-260C-UNLIM | -40 to 85 | LVTH245A | Samples |
| SN74LVTH245APW | ACTIVE | TSSOP | PW | 20 | 70 | Green (RoHS & no Sb/Br) | CU NIPDAU | Level-1-260C-UNLIM | -40 to 85 | LXH245A | Samples |
| SN74LVTH245APWE4 | ACTIVE | TSSOP | PW | 20 | 70 | Green (RoHS & no Sb/Br) | CU NIPDAU | Level-1-260C-UNLIM | -40 to 85 | LXH245A | Samples |
| SN74LVTH245APWG4 | ACTIVE | TSSOP | PW | 20 | 70 | Green (RoHS & no Sb/Br) | CU NIPDAU | Level-1-260C-UNLIM | -40 to 85 | LXH245A | Samples |
| SN74LVTH245APWLE | OBSOLETE | TSSOP | PW | 20 | | TBD | Call TI | Call TI | -40 to 85 | | |
| SN74LVTH245APWR | ACTIVE | TSSOP | PW | 20 | 2000 | Green (RoHS & no Sb/Br) | CU NIPDAU CU SN | Level-1-260C-UNLIM | -40 to 85 | LXH245A | Samples |
| SN74LVTH245APWRE4 | ACTIVE | TSSOP | PW | 20 | 2000 | Green (RoHS & no Sb/Br) | CU NIPDAU | Level-1-260C-UNLIM | -40 to 85 | LXH245A | Samples |
| SN74LVTH245APWRG4 | ACTIVE | TSSOP | PW | 20 | 2000 | Green (RoHS & no Sb/Br) | CU NIPDAU | Level-1-260C-UNLIM | -40 to 85 | LXH245A | Samples |
| SN74LVTH245ARGYR | ACTIVE | VQFN | RGY | 20 | 3000 | Green (RoHS & no Sb/Br) | CU NIPDAU | Level-2-260C-1 YEAR | -40 to 85 | LXH245A | Samples |
| SNJ54LVTH245AFK | ACTIVE | LCCC | FK | 20 | 1 | TBD | POST-PLATE | N / A for Pkg Type | -55 to 125 | 5962- 9564201Q2A SNJ54LVTH 245AFK | Samples |
| SNJ54LVTH245AJ | ACTIVE | CDIP | J | 20 | 1 | TBD | A42 | N / A for Pkg Type | -55 to 125 | 5962-9564201QR A SNJ54LVTH245AJ | Samples |
| SNJ54LVTH245AW | ACTIVE | CFP | W | 20 | 1 | TBD | A42 | N / A for Pkg Type | -55 to 125 | 5962-9564201QS A SNJ54LVTH245AW | Samples |

(1) The marketing status values are defined as follows:

ACTIVE: Product device recommended for new designs.

LIFEBUY: TI has announced that the device will be discontinued, and a lifetime-buy period is in effect.

NRND: Not recommended for new designs. Device is in production to support existing customers, but TI does not recommend using this part in a new design.

PREVIEW: Device has been announced but is not in production. Samples may or may not be available.

OBSELETE: TI has discontinued the production of the device.

⁽²⁾ Eco Plan - The planned eco-friendly classification: Pb-Free (RoHS), Pb-Free (RoHS Exempt), or Green (RoHS & no Sb/Br) - please check <http://www.ti.com/productcontent> for the latest availability information and additional product content details.

TBD: The Pb-Free/Green conversion plan has not been defined.

Pb-Free (RoHS): TI's terms "Lead-Free" or "Pb-Free" mean semiconductor products that are compatible with the current RoHS requirements for all 6 substances, including the requirement that lead not exceed 0.1% by weight in homogeneous materials. Where designed to be soldered at high temperatures, TI Pb-Free products are suitable for use in specified lead-free processes.

Pb-Free (RoHS Exempt): This component has a RoHS exemption for either 1) lead-based flip-chip solder bumps used between the die and package, or 2) lead-based die adhesive used between the die and leadframe. The component is otherwise considered Pb-Free (RoHS compatible) as defined above.

Green (RoHS & no Sb/Br): TI defines "Green" to mean Pb-Free (RoHS compatible), and free of Bromine (Br) and Antimony (Sb) based flame retardants (Br or Sb do not exceed 0.1% by weight in homogeneous material)

⁽³⁾ MSL, Peak Temp. - The Moisture Sensitivity Level rating according to the JEDEC industry standard classifications, and peak solder temperature.

⁽⁴⁾ There may be additional marking, which relates to the logo, the lot trace code information, or the environmental category on the device.

⁽⁵⁾ Multiple Device Markings will be inside parentheses. Only one Device Marking contained in parentheses and separated by a "~" will appear on a device. If a line is indented then it is a continuation of the previous line and the two combined represent the entire Device Marking for that device.

⁽⁶⁾ Lead/Ball Finish - Orderable Devices may have multiple material finish options. Finish options are separated by a vertical ruled line. Lead/Ball Finish values may wrap to two lines if the finish value exceeds the maximum column width.

Important Information and Disclaimer:The information provided on this page represents TI's knowledge and belief as of the date that it is provided. TI bases its knowledge and belief on information provided by third parties, and makes no representation or warranty as to the accuracy of such information. Efforts are underway to better integrate information from third parties. TI has taken and continues to take reasonable steps to provide representative and accurate information but may not have conducted destructive testing or chemical analysis on incoming materials and chemicals. TI and TI suppliers consider certain information to be proprietary, and thus CAS numbers and other limited information may not be available for release.

In no event shall TI's liability arising out of such information exceed the total purchase price of the TI part(s) at issue in this document sold by TI to Customer on an annual basis.

OTHER QUALIFIED VERSIONS OF SN54LVTH245A, SN54LVTH245A-SP, SN74LVTH245A :

- Catalog: [SN74LVTH245A](#), [SN54LVTH245A](#)
- Enhanced Product: [SN74LVTH245A-EP](#), [SN74LVTH245A-EP](#)
- Military: [SN54LVTH245A](#)
- Space: [SN54LVTH245A-SP](#)

NOTE: Qualified Version Definitions:

- Catalog - TI's standard catalog product
- Enhanced Product - Supports Defense, Aerospace and Medical Applications
- Military - QML certified for Military and Defense Applications
- Space - Radiation tolerant, ceramic packaging and qualified for use in Space-based application

TAPE AND REEL INFORMATION

QUADRANT ASSIGNMENTS FOR PIN 1 ORIENTATION IN TAPE

*All dimensions are nominal

| Device | Package Type | Package Drawing | Pins | SPQ | Reel Diameter (mm) | Reel Width W1 (mm) | A0 (mm) | B0 (mm) | K0 (mm) | P1 (mm) | W (mm) | Pin1 Quadrant |
|------------------|--------------|-----------------|------|------|--------------------|--------------------|---------|---------|---------|---------|--------|---------------|
| SN74LVTH245ADBR | SSOP | DB | 20 | 2000 | 330.0 | 16.4 | 8.2 | 7.5 | 2.5 | 12.0 | 16.0 | Q1 |
| SN74LVTH245ADWR | SOIC | DW | 20 | 2000 | 330.0 | 24.4 | 10.8 | 13.3 | 2.7 | 12.0 | 24.0 | Q1 |
| SN74LVTH245ANSR | SO | NS | 20 | 2000 | 330.0 | 24.4 | 9.0 | 13.0 | 2.4 | 4.0 | 24.0 | Q1 |
| SN74LVTH245APWR | TSSOP | PW | 20 | 2000 | 330.0 | 16.4 | 6.95 | 7.1 | 1.6 | 8.0 | 16.0 | Q1 |
| SN74LVTH245APWR | TSSOP | PW | 20 | 2000 | 330.0 | 16.4 | 6.95 | 7.1 | 1.6 | 8.0 | 16.0 | Q1 |
| SN74LVTH245ARGYR | VQFN | RGY | 20 | 3000 | 330.0 | 12.4 | 3.8 | 4.8 | 1.6 | 8.0 | 12.0 | Q1 |

TAPE AND REEL BOX DIMENSIONS

*All dimensions are nominal

| Device | Package Type | Package Drawing | Pins | SPQ | Length (mm) | Width (mm) | Height (mm) |
|------------------|--------------|-----------------|------|------|-------------|------------|-------------|
| SN74LVTH245ADBR | SSOP | DB | 20 | 2000 | 367.0 | 367.0 | 38.0 |
| SN74LVTH245ADWR | SOIC | DW | 20 | 2000 | 367.0 | 367.0 | 45.0 |
| SN74LVTH245ANSR | SO | NS | 20 | 2000 | 367.0 | 367.0 | 45.0 |
| SN74LVTH245APWR | TSSOP | PW | 20 | 2000 | 367.0 | 367.0 | 38.0 |
| SN74LVTH245APWR | TSSOP | PW | 20 | 2000 | 364.0 | 364.0 | 27.0 |
| SN74LVTH245ARGYR | VQFN | RGY | 20 | 3000 | 367.0 | 367.0 | 35.0 |

J (R-GDIP-T**)

14 LEADS SHOWN

CERAMIC DUAL IN-LINE PACKAGE



| DIM \ PINS ** | 14 | 16 | 18 | 20 |
|---------------|------------------------|------------------------|------------------------|------------------------|
| A | 0.300 (7,62) BSC | 0.300 (7,62) BSC | 0.300 (7,62) BSC | 0.300 (7,62) BSC |
| B MAX | 0.785 (19,94) | .840 (21,34) | 0.960 (24,38) | 1.060 (26,92) |
| B MIN | — | — | — | — |
| C MAX | 0.300 (7,62) | 0.300 (7,62) | 0.310 (7,87) | 0.300 (7,62) |
| C MIN | 0.245 (6,22) | 0.245 (6,22) | 0.220 (5,59) | 0.245 (6,22) |



4040083/F 03/03

- NOTES:
- All linear dimensions are in inches (millimeters).
 - This drawing is subject to change without notice.
 - This package is hermetically sealed with a ceramic lid using glass frit.
 - Index point is provided on cap for terminal identification only on press ceramic glass frit seal only.
 - Falls within MIL STD 1835 GDIP1-T14, GDIP1-T16, GDIP1-T18 and GDIP1-T20.

W (R-GDFP-F20)

CERAMIC DUAL FLATPACK



- NOTES:
- A. All linear dimensions are in inches (millimeters).
 - B. This drawing is subject to change without notice.
 - C. This package can be hermetically sealed with a ceramic lid using glass frit.
 - D. Index point is provided on cap for terminal identification only.
 - E. Falls within Mil-Std 1835 GDFP2-F20

FK (S-CQCC-N**)

LEADLESS CERAMIC CHIP CARRIER

28 TERMINAL SHOWN



| NO. OF TERMINALS ** | A | | B | |
|---------------------|------------------|------------------|------------------|------------------|
| | MIN | MAX | MIN | MAX |
| 20 | 0.342 (8,69) | 0.358 (9,09) | 0.307 (7,80) | 0.358 (9,09) |
| 28 | 0.442 (11,23) | 0.458 (11,63) | 0.406 (10,31) | 0.458 (11,63) |
| 44 | 0.640 (16,26) | 0.660 (16,76) | 0.495 (12,58) | 0.560 (14,22) |
| 52 | 0.740 (18,78) | 0.761 (19,32) | 0.495 (12,58) | 0.560 (14,22) |
| 68 | 0.938 (23,83) | 0.962 (24,43) | 0.850 (21,6) | 0.858 (21,8) |
| 84 | 1.141 (28,99) | 1.165 (29,59) | 1.047 (26,6) | 1.063 (27,0) |

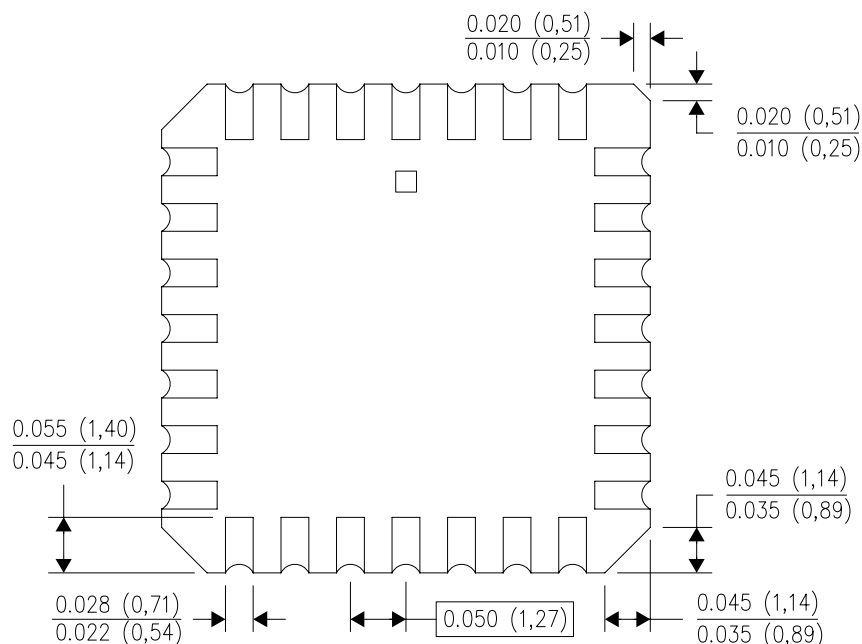

4040140/D 01/11

- NOTES:
- All linear dimensions are in inches (millimeters).
 - This drawing is subject to change without notice.
 - This package can be hermetically sealed with a metal lid.
 - Falls within JEDEC MS-004

GQN (R-PBGA-N20)

PLASTIC BALL GRID ARRAY

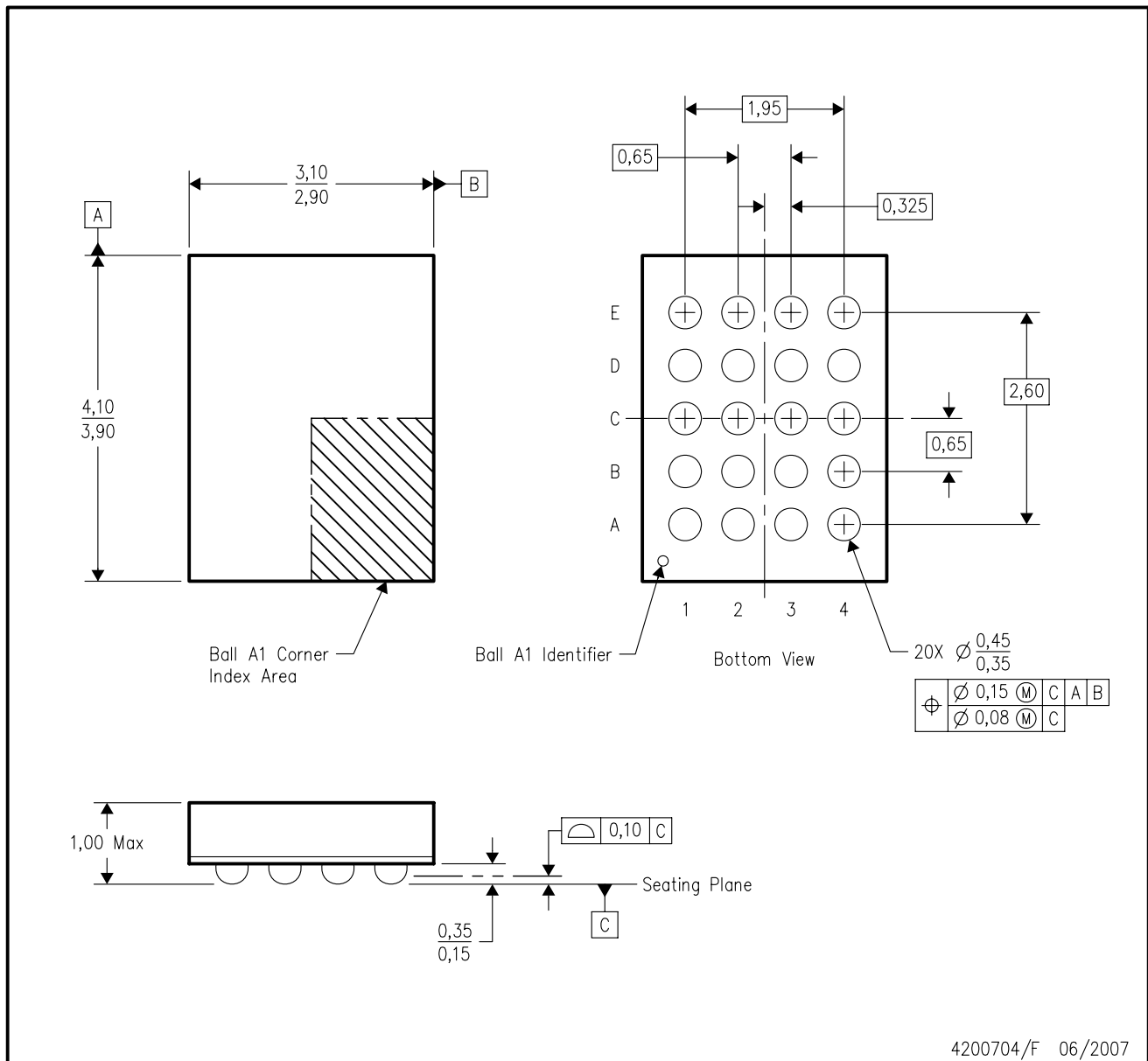

4200704/F 06/2007

- NOTES:
- A. All linear dimensions are in millimeters. Dimensioning and tolerancing per ASME Y14.5M-1994.
 - B. This drawing is subject to change without notice.
 - C. Falls within JEDEC MO-285 variation BC-2.
 - D. This package is tin-lead (SnPb). Refer to the 20 ZQN package (drawing 4204492) for lead-free.

DW0020A



PACKAGE OUTLINE

SOIC - 2.65 mm max height

SOIC



4220724/A 05/2016

EXAMPLE BOARD LAYOUT

DW0020A

SOIC - 2.65 mm max height

SOIC



LAND PATTERN EXAMPLE
SCALE:6X



SOLDER MASK DETAILS

4220724/A 05/2016

NOTES: (continued)

- 6. Publication IPC-7351 may have alternate designs.
- 7. Solder mask tolerances between and around signal pads can vary based on board fabrication site.

EXAMPLE STENCIL DESIGN

DW0020A

SOIC - 2.65 mm max height

SOIC



SOLDER PASTE EXAMPLE
BASED ON 0.125 mm THICK STENCIL
SCALE:6X

4220724/A 05/2016

NOTES: (continued)

8. Laser cutting apertures with trapezoidal walls and rounded corners may offer better paste release. IPC-7525 may have alternate design recommendations.
9. Board assembly site may have different recommendations for stencil design.

PW (R-PDSO-G20)

PLASTIC SMALL OUTLINE

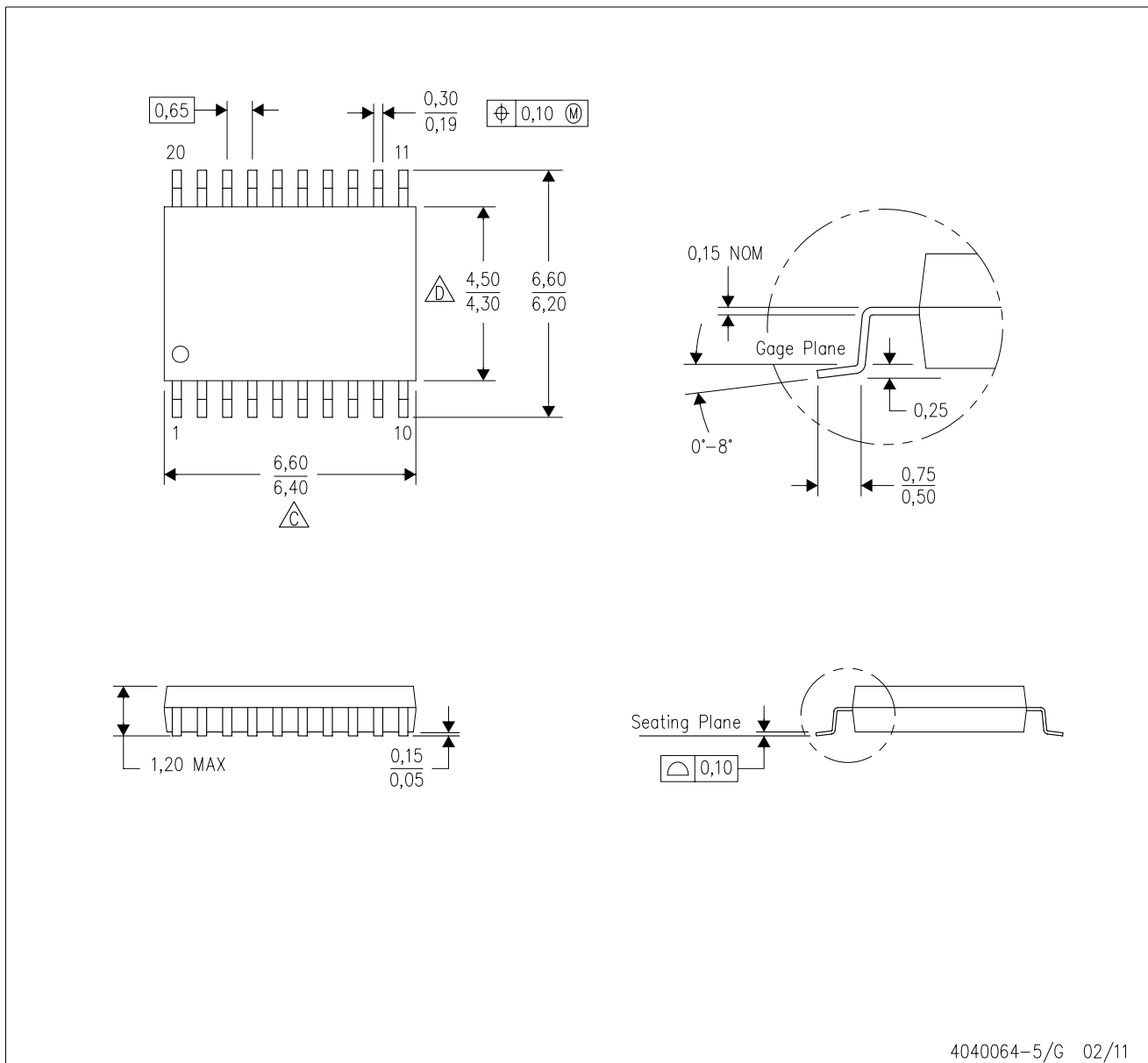

4040064-5/G 02/11

- NOTES:
- A. All linear dimensions are in millimeters. Dimensioning and tolerancing per ASME Y14.5M-1994.
 - B. This drawing is subject to change without notice.
 - C. Body length does not include mold flash, protrusions, or gate burrs. Mold flash, protrusions, or gate burrs shall not exceed 0,15 each side.
 - D. Body width does not include interlead flash. Interlead flash shall not exceed 0,25 each side.
 - E. Falls within JEDEC MO-153

PW (R-PDSO-G20)

PLASTIC SMALL OUTLINE

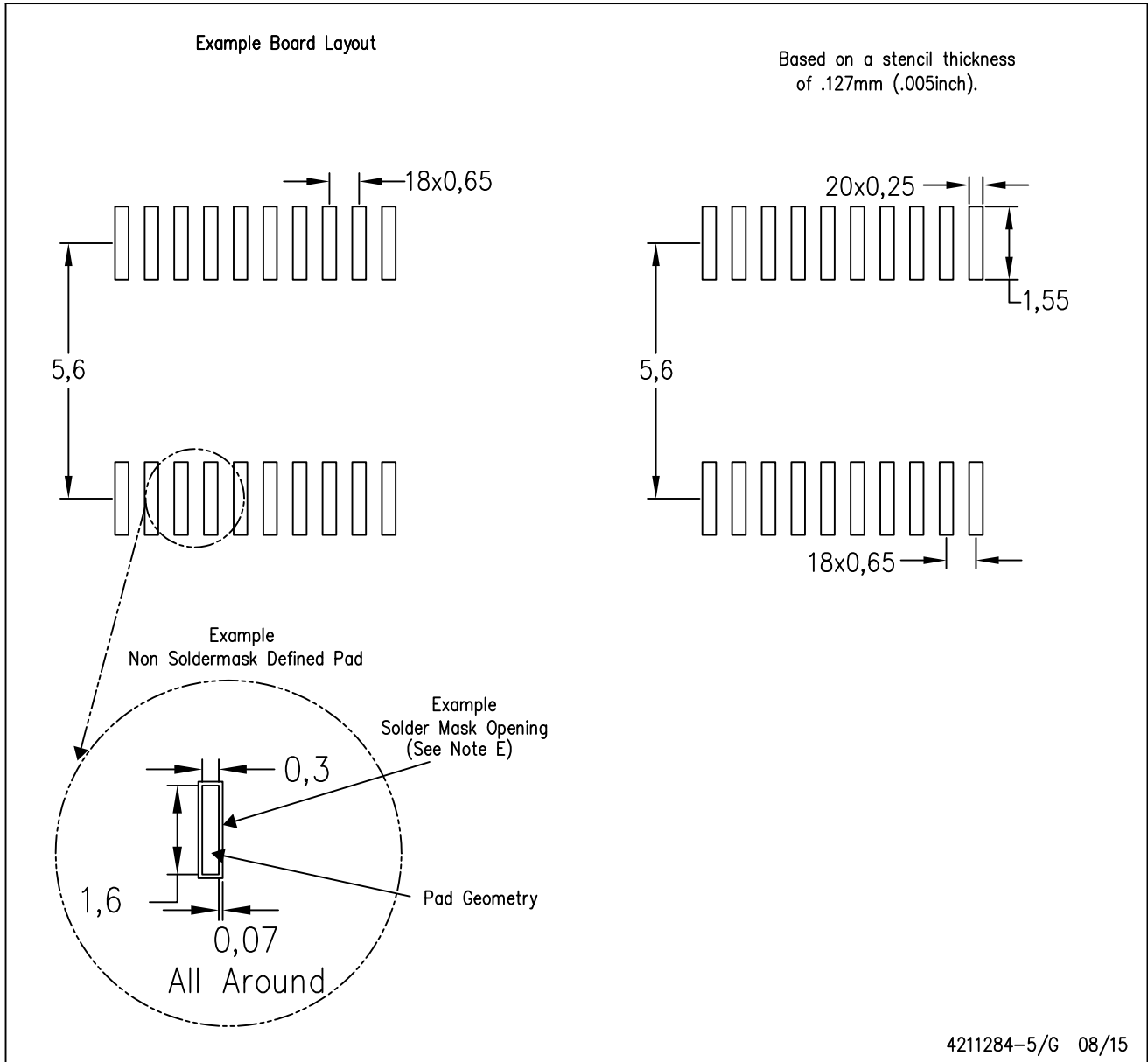

- NOTES:
- A. All linear dimensions are in millimeters.
 - B. This drawing is subject to change without notice.
 - C. Publication IPC-7351 is recommended for alternate design.
 - D. Laser cutting apertures with trapezoidal walls and also rounding corners will offer better paste release. Customers should contact their board assembly site for stencil design recommendations. Refer to IPC-7525 for other stencil recommendations.
 - E. Customers should contact their board fabrication site for solder mask tolerances between and around signal pads.

DB (R-PDSO-G**)

PLASTIC SMALL-OUTLINE

28 PINS SHOWN



- NOTES: A. All linear dimensions are in millimeters.
 B. This drawing is subject to change without notice.
 C. Body dimensions do not include mold flash or protrusion not to exceed 0,15.
 D. Falls within JEDEC MO-150

RGY (R-PVQFN-N20)

PLASTIC QUAD FLATPACK NO-LEAD

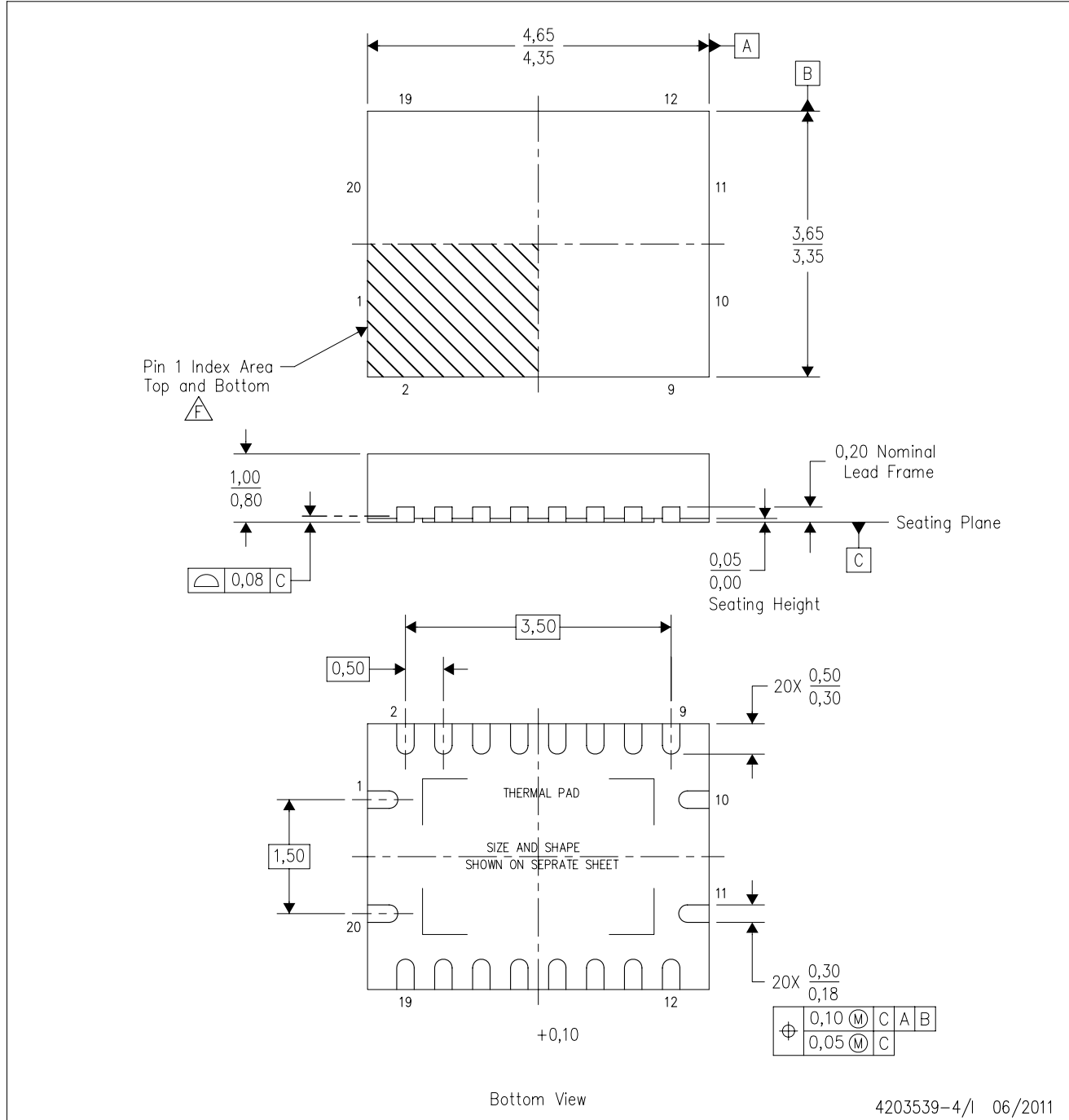

- NOTES:
- All linear dimensions are in millimeters. Dimensioning and tolerancing per ASME Y14.5M-1994.
 - This drawing is subject to change without notice.
 - QFN (Quad Flatpack No-Lead) package configuration.
 - The package thermal pad must be soldered to the board for thermal and mechanical performance.
 - See the additional figure in the Product Data Sheet for details regarding the exposed thermal pad features and dimensions.
 - Pin 1 identifiers are located on both top and bottom of the package and within the zone indicated. The Pin 1 identifiers are either a molded, marked, or metal feature.
 - Package complies to JEDEC MO-241 variation BA.

RGY (R-PVQFN-N20)

PLASTIC QUAD FLATPACK NO-LEAD

THERMAL INFORMATION

This package incorporates an exposed thermal pad that is designed to be attached directly to an external heatsink. The thermal pad must be soldered directly to the printed circuit board (PCB). After soldering, the PCB can be used as a heatsink. In addition, through the use of thermal vias, the thermal pad can be attached directly to the appropriate copper plane shown in the electrical schematic for the device, or alternatively, can be attached to a special heatsink structure designed into the PCB. This design optimizes the heat transfer from the integrated circuit (IC).

For information on the Quad Flatpack No-Lead (QFN) package and its advantages, refer to Application Report, QFN/SON PCB Attachment, Texas Instruments Literature No. SLUA271. This document is available at www.ti.com.

The exposed thermal pad dimensions for this package are shown in the following illustration.

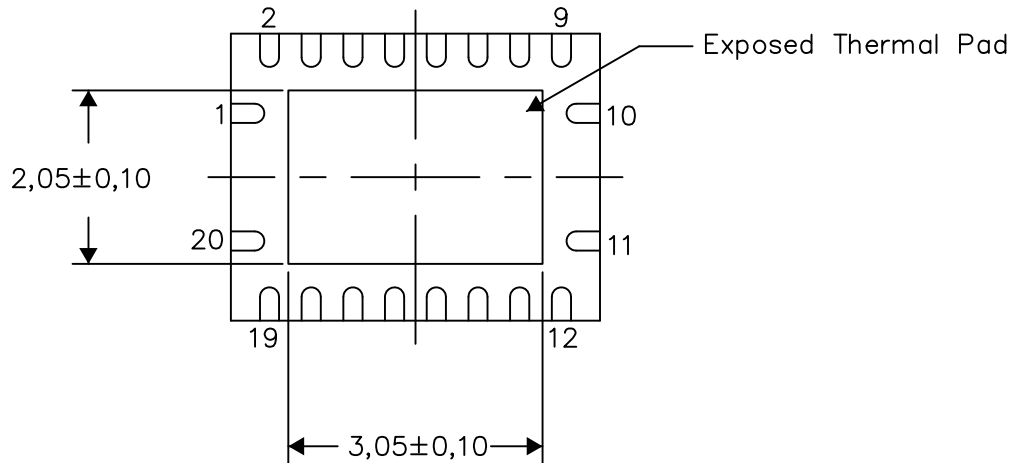

Bottom View

Exposed Thermal Pad Dimensions

4206353-4/P 03/14

NOTE: All linear dimensions are in millimeters

RGY (R-PVQFN-N20)

PLASTIC QUAD FLATPACK NO-LEAD

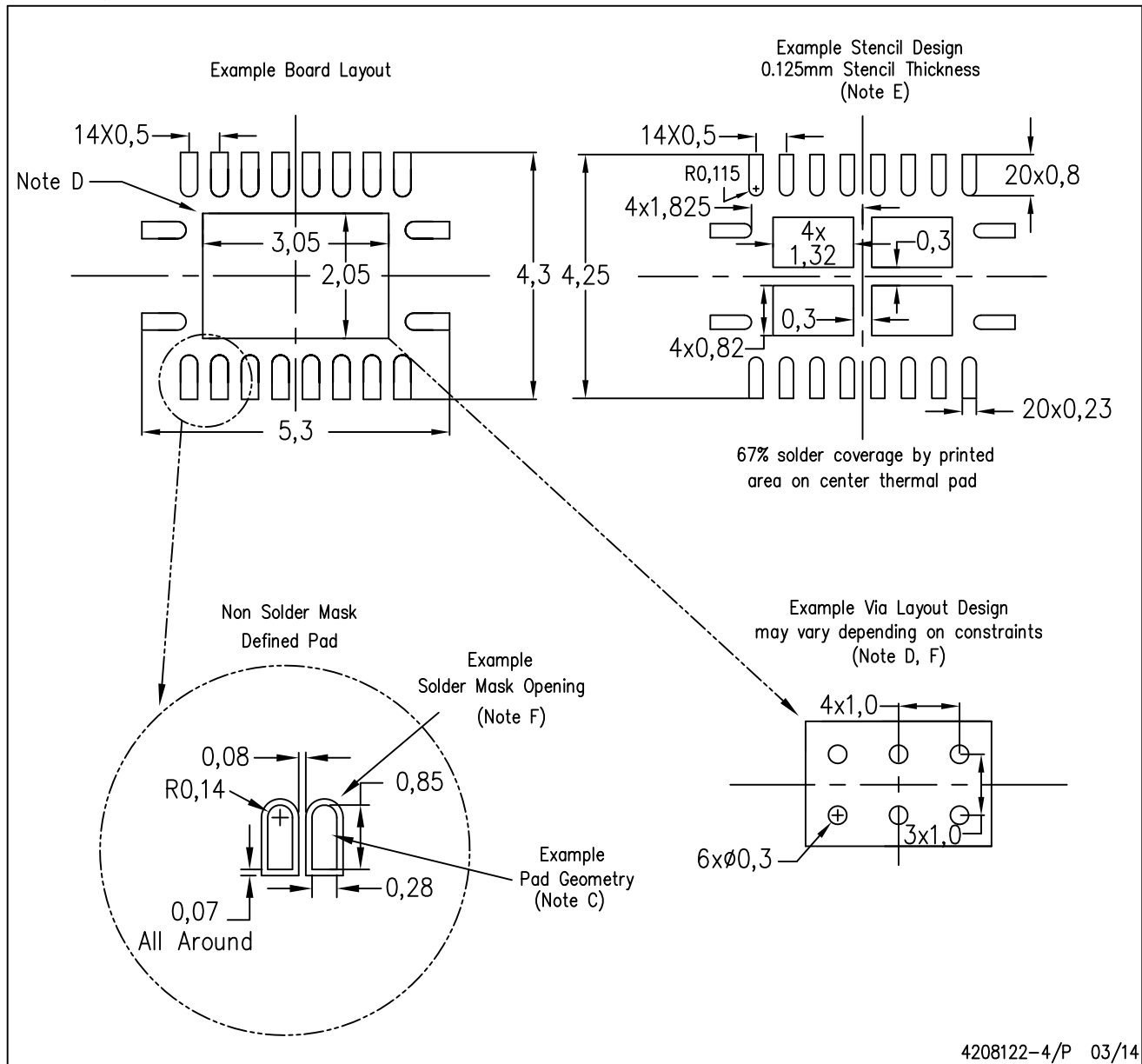

- NOTES:
- A. All linear dimensions are in millimeters.
 - B. This drawing is subject to change without notice.
 - C. Publication IPC-7351 is recommended for alternate designs.
 - D. This package is designed to be soldered to a thermal pad on the board. Refer to Application Note, Quad Flat-Pack QFN/SON PCB Attachment, Texas Instruments Literature No. SLUA271, and also the Product Data Sheets for specific thermal information, via requirements, and recommended board layout. These documents are available at www.ti.com <<http://www.ti.com>>.
 - E. Laser cutting apertures with trapezoidal walls and also rounding corners will offer better paste release. Customers should contact their board assembly site for stencil design recommendations. Refer to IPC 7525 for stencil design considerations.
 - F. Customers should contact their board fabrication site for minimum solder mask web tolerances between signal pads.

MECHANICAL DATA

NS (R-PDSO-G**)

PLASTIC SMALL-OUTLINE PACKAGE

14-PINS SHOWN



- NOTES:
- A. All linear dimensions are in millimeters.
 - B. This drawing is subject to change without notice.
 - C. Body dimensions do not include mold flash or protrusion, not to exceed 0,15.

IMPORTANT NOTICE

Texas Instruments Incorporated and its subsidiaries (TI) reserve the right to make corrections, enhancements, improvements and other changes to its semiconductor products and services per JESD46, latest issue, and to discontinue any product or service per JESD48, latest issue. Buyers should obtain the latest relevant information before placing orders and should verify that such information is current and complete. All semiconductor products (also referred to herein as "components") are sold subject to TI's terms and conditions of sale supplied at the time of order acknowledgment.

TI warrants performance of its components to the specifications applicable at the time of sale, in accordance with the warranty in TI's terms and conditions of sale of semiconductor products. Testing and other quality control techniques are used to the extent TI deems necessary to support this warranty. Except where mandated by applicable law, testing of all parameters of each component is not necessarily performed.

TI assumes no liability for applications assistance or the design of Buyers' products. Buyers are responsible for their products and applications using TI components. To minimize the risks associated with Buyers' products and applications, Buyers should provide adequate design and operating safeguards.

TI does not warrant or represent that any license, either express or implied, is granted under any patent right, copyright, mask work right, or other intellectual property right relating to any combination, machine, or process in which TI components or services are used. Information published by TI regarding third-party products or services does not constitute a license to use such products or services or a warranty or endorsement thereof. Use of such information may require a license from a third party under the patents or other intellectual property of the third party, or a license from TI under the patents or other intellectual property of TI.

Reproduction of significant portions of TI information in TI data books or data sheets is permissible only if reproduction is without alteration and is accompanied by all associated warranties, conditions, limitations, and notices. TI is not responsible or liable for such altered documentation. Information of third parties may be subject to additional restrictions.

Resale of TI components or services with statements different from or beyond the parameters stated by TI for that component or service voids all express and any implied warranties for the associated TI component or service and is an unfair and deceptive business practice. TI is not responsible or liable for any such statements.

Buyer acknowledges and agrees that it is solely responsible for compliance with all legal, regulatory and safety-related requirements concerning its products, and any use of TI components in its applications, notwithstanding any applications-related information or support that may be provided by TI. Buyer represents and agrees that it has all the necessary expertise to create and implement safeguards which anticipate dangerous consequences of failures, monitor failures and their consequences, lessen the likelihood of failures that might cause harm and take appropriate remedial actions. Buyer will fully indemnify TI and its representatives against any damages arising out of the use of any TI components in safety-critical applications.

In some cases, TI components may be promoted specifically to facilitate safety-related applications. With such components, TI's goal is to help enable customers to design and create their own end-product solutions that meet applicable functional safety standards and requirements. Nonetheless, such components are subject to these terms.

No TI components are authorized for use in FDA Class III (or similar life-critical medical equipment) unless authorized officers of the parties have executed a special agreement specifically governing such use.

Only those TI components which TI has specifically designated as military grade or "enhanced plastic" are designed and intended for use in military/aerospace applications or environments. Buyer acknowledges and agrees that any military or aerospace use of TI components which have **not** been so designated is solely at the Buyer's risk, and that Buyer is solely responsible for compliance with all legal and regulatory requirements in connection with such use.

TI has specifically designated certain components as meeting ISO/TS16949 requirements, mainly for automotive use. In any case of use of non-designated products, TI will not be responsible for any failure to meet ISO/TS16949.

Products

| | |
|------------------------------|--|
| Audio | www.ti.com/audio |
| Amplifiers | amplifier.ti.com |
| Data Converters | dataconverter.ti.com |
| DLP® Products | www.dlp.com |
| DSP | dsp.ti.com |
| Clocks and Timers | www.ti.com/clocks |
| Interface | interface.ti.com |
| Logic | logic.ti.com |
| Power Mgmt | power.ti.com |
| Microcontrollers | microcontroller.ti.com |
| RFID | www.ti-rfid.com |
| OMAP Applications Processors | www.ti.com/omap |
| Wireless Connectivity | www.ti.com/wirelessconnectivity |

Applications

| | |
|-------------------------------|--|
| Automotive and Transportation | www.ti.com/automotive |
| Communications and Telecom | www.ti.com/communications |
| Computers and Peripherals | www.ti.com/computers |
| Consumer Electronics | www.ti.com/consumer-apps |
| Energy and Lighting | www.ti.com/energy |
| Industrial | www.ti.com/industrial |
| Medical | www.ti.com/medical |
| Security | www.ti.com/security |
| Space, Avionics and Defense | www.ti.com/space-avionics-defense |
| Video and Imaging | www.ti.com/video |

TI E2E Community

e2e.ti.com