

## SP-GB-ZX-xxA

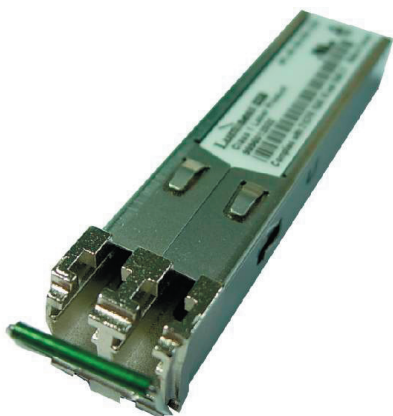

## Features

- Data rate 1.062 to 1.25 Gb/s
- Single 3.3 V supply
- 80 km reach
- 24 dB min, 28 dB typical link budget
- 1550 nm DFB laser
- Commercial temperature available
- Industrial temperature available
- 1550 nm DFB laser
- Digital Diagnostic SFF-8472 compliant
- SFP MSA SFF-8074i compliant
- Bellcore GR-468 compliant
- TUV certificate number R50075336 0001
- Color coded bail latch tube: Green
- RoHS compliant

## General Operating

Parameter	Symbol	Min.	Typical	Max.	Unit
Supply Voltage	$V_{cc}$	3.135	3.3	3.465A	V
Total Current	$I_{cc}$	-	-	300	mA
Power Supply Rejection <sup>a</sup>	PSR	100	-	-	mV <sub>p-p</sub>
Operating Temperature (-CDA)	$T_{op}$	-5	-	70	°C
Operating Temperature (-TDA)	$T_{op}$	-40	-	85	°C
Operating Temperature (-RDA)	$T_{op}$	-20	-	85	°C
Storage Temperature	$T_{st}$	-40	-	85	°C
Data Rate GbE	DR	-	1250	-	Mbps
Data Rate FC	DR	-	1062.5	-	Mbps

a) 20Hz to 155MHz

## Transmitter Specifications (Optical)

Parameter	Symbol	Min	Typical	Max	Unit
Optical Power	$P_{op}$	0	2	5	dBm
Average Launch Power Of Off Tx	$P_{off}$	-	-	-45	dBm
Extinction Ratio (Dynamic)	ER	9	-	-	dB
Eye Mask		-	-	-	802.3z compliant
Total Jitter	TJ	-	-	200	ps
Optical Rise Time <sup>b</sup>	$t_r$	-	-	260	ps
Optical Fall Time <sup>b</sup>	$t_f$	-	-	260	ps
Mean Wavelength	$\lambda$	1535	1550	1565	nm
Spectral Width (20dB)	$\Delta \lambda$	-	-	1	nm
Side Mode Suppression Ratio	SMSR	30	-	-	dB
Optical Path Penalty at 80 Km <sup>c</sup>	dp	-	1	2	dB
Relative Intensity Noise	RIN	-	-	-120	dB/Hz
Reflection Toleranced <sup>d</sup>	rp	-24	-	-	dB

b) 20%-80% values

c) Measured at BER of  $10^{-12}$ , PRBS of 27-1, at eye center

d) 1dB degradation of receiver sensitivity

## SP-GB-ZX-xxA

## Transmitter Specifications (Electical)

Parameter	Symbol	Min	Typical	Max	Unit
Input Differential Impedence	$R_{in}$	80	100	120	$\Omega$
PECL Single Ended Data Input Swing	$V_{in,p-p}$	250	-	1200	mV
TxFault_Fault	$V_{fault}$	2	-	$V_{cc}$	V
TxFault_Normal	$V_{normal}$	$V_{ee}$	-	$V_{ee}+0.5$	V
TxDisable_Disable	$V_d$	2	-	$V_{cc}$	V
TxDisable_Enable	$V_{en}$	$V_{ee}$	-	$V_{ee}+0.8$	V

## Receiver Specifications

Parameter	Symbol	Min	Typical	Max	Unit
Receive Power Low <sup>e</sup>	$R_{sens,low}$	-	-26	-24	dBm
Receive Power High	$R_{sens,high}$	-3	0	-	dBm
Damage Threshold For Receiver	$P_{in,damage}$	6	-	-	dBm
Wavelength <sup>f</sup>	$\lambda$	1535	1550	1565	nm
Maximum Reflectance Of Receiver	$RX_r$	-	-	-12	dB
LOS Assert		-38	-	-	dBm
LOS De-assert		-	-	-24	dBm
LOS Hysteresis		0.5	-	-	dB

e)  $10^{-12}$  at nominal wavelength

f) Operational over 1200-1625nm range

## Electrical Output

Parameter	Symbol	Min	Typical	Max	Unit
PECL Single Ended Data Output Swing	$V_{out,p-p}$	185	-	800	mV
Data Output Rise Time	$t_r$	-	-	260	ps
Data Output Fall Time	$t_f$	-	-	260	ps

## Timing and Electrical

Parameter	Symbol	Min	Typical	Max	Unit
Tx Disable Negate Time	$t_{on}$	-	-	1	ms
Tx Disable Assert Time	$t_{off}$	-	-	10	$\mu$ s
Time To Initialize, Including Reset Of Tx Fault	$t_{init}$	-	-	300	ms
Tx Fault Assert Time	$t_{fault}$	-	-	100	$\mu$ s
Tx Disable To Reset	$t_{reset}$	10	-	-	$\mu$ s
LOS Assert Time	$t_{loss_{on}}$	-	-	100	$\mu$ s
LOS De-assert Time	$t_{loss_{off}}$	-	-	100	$\mu$ s
Serial ID Clock Rate	$f_{serial\_clock}$	2	-	100	KHz
RX_LOS Voltage (High)		2	-	$V_{cc}$	V
RX_LOS Voltage (Low)		-	-	0.8	V
MOD_DEF (0:2)-High	$V_H$	2	-	$V_{cc}$	V
MOD_DEF (0:2)-Low	$V_L$	$V_{ee}$	-	$V_{ee}+0.5$	V
LOS Output Voltage-Fault	$V_{LOS\ fault}$	2	-	$V_{cc}$	V
LOS Output Voltage-Normal	$V_{LOS\ normal}$	$V_{ee}$	-	$V_{ee}+0.5$	V

SP-GB-ZX-xxA

Diagnostics

Parameter	Range	Accuracy	Unit	Calibration	Formula
Temperature (-CDA)	-5 to 70	± 3	° C	Internal	$T_c(C) = T_{ad}(16 \text{ bit signed twos complement})/256$
Temperature (-RDA)	-20 to 85	± 3	° C	Internal	$T_c(C) = T_{ad}(16 \text{ bit signed twos complement})/256$
Temperature (-TDA)	-40 to 85	± 3	° C	Internal	$T_c(C) = T_{ad}(16 \text{ bit signed twos complement})/256$
Voltage	0 to $V_{cc}$	± 0.1	V	Internal	$V(\text{Volts}) = V_{ad}(16 \text{ bit unsigned integer}) * 0.1$
Bias Current	0 to 120	± 5	mA	External	$I(\text{mA}) = I_{slope} * I_{ad}(16 \text{ bit unsigned integer}) + I_{offset}$
TX Power	0 to 5	±3 dB	dBm	External	$TX\_PWR(\mu W) = TX\_PWR_{slope} * TX\_PWR_{ad}(16 \text{ bit unsigned integer}) + TX\_PWR_{offset}$
RX Power	-24 to -3	±3 dB	dBm	External	$RX\_PWR(\mu W) = A_0 + A_1 * x + A_2 * x^2 + A_3 * x^3 + A_4 * x^4$

EEPROM Serial ID

Name of Field	Description of Field	Address	Hex	ASCII
Vendor Name	SFP Vendor Name(ASCII)	20	4C	L
		21	55	U
		22	4D	M
		23	49	I
		24	4E	N
		25	45	E
		26	4E	N
		27	54	T
		28	4F	O
		29	49	I
		30	43	C
Vendor OUI	IEEE Vendor OUI Code For LuminentOIC Inc.	37	00	
		38	06	
		39	B5	
Vendor PN	Part Number in ASCII, e.g. SP-GB-ZX-CDA	40	53	S
		41	50	P
		42	47	G
		43	42	B
		44	5A	Z
		45	58	X
		46	43	C
		47	44	D
		48	41	A

## SP-GB-ZX-xxA

Pin	Function	Notes
1	V <sub>ee</sub> T	TX GND
2	TX_FAULT	Open Collector
3	TX_DISABLE	Internally Pulled High
4	MOD_DEF2	Serial Data Input
5	MOD_DEF1	Serial Clock Input
6	MOD_DEF0	Internally Grounded
7	NC	Not Connected
8	LOS	Open Collector
9	V <sub>ee</sub> R	RX Ground
10	V <sub>ee</sub> R	RX Ground
11	V <sub>ee</sub> R	RX Ground
12	RZX-	RX Data Negative
13	RXD+	RX Data Positive
14	V <sub>ee</sub> R	RX GND
15	V <sub>cc</sub> R	RX Power
16	V <sub>cc</sub> T	TX Power
17	V <sub>ee</sub> T	TX GND
18	TXD+	TX Data Positive
19	TZX-	TX Data Negative
20	V <sub>ee</sub> T	TX GND

SP-GB-ZX-xxA

Outline Drawing

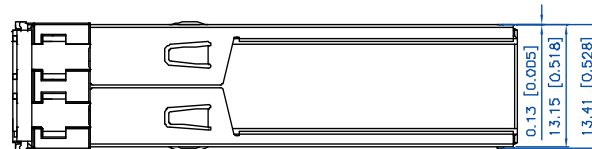
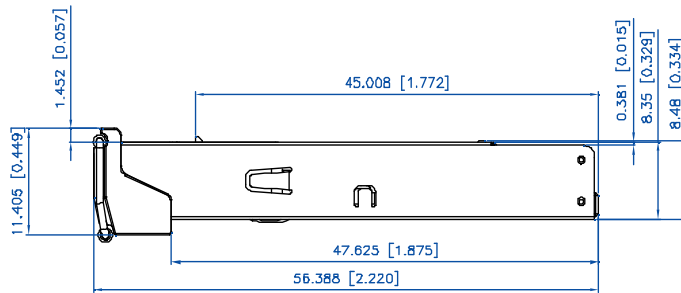
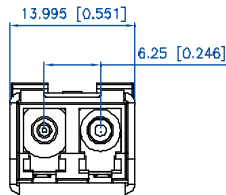

Units in mm(inches)

SP-GB-ZX-xxA

Suggested Transceiver Interface

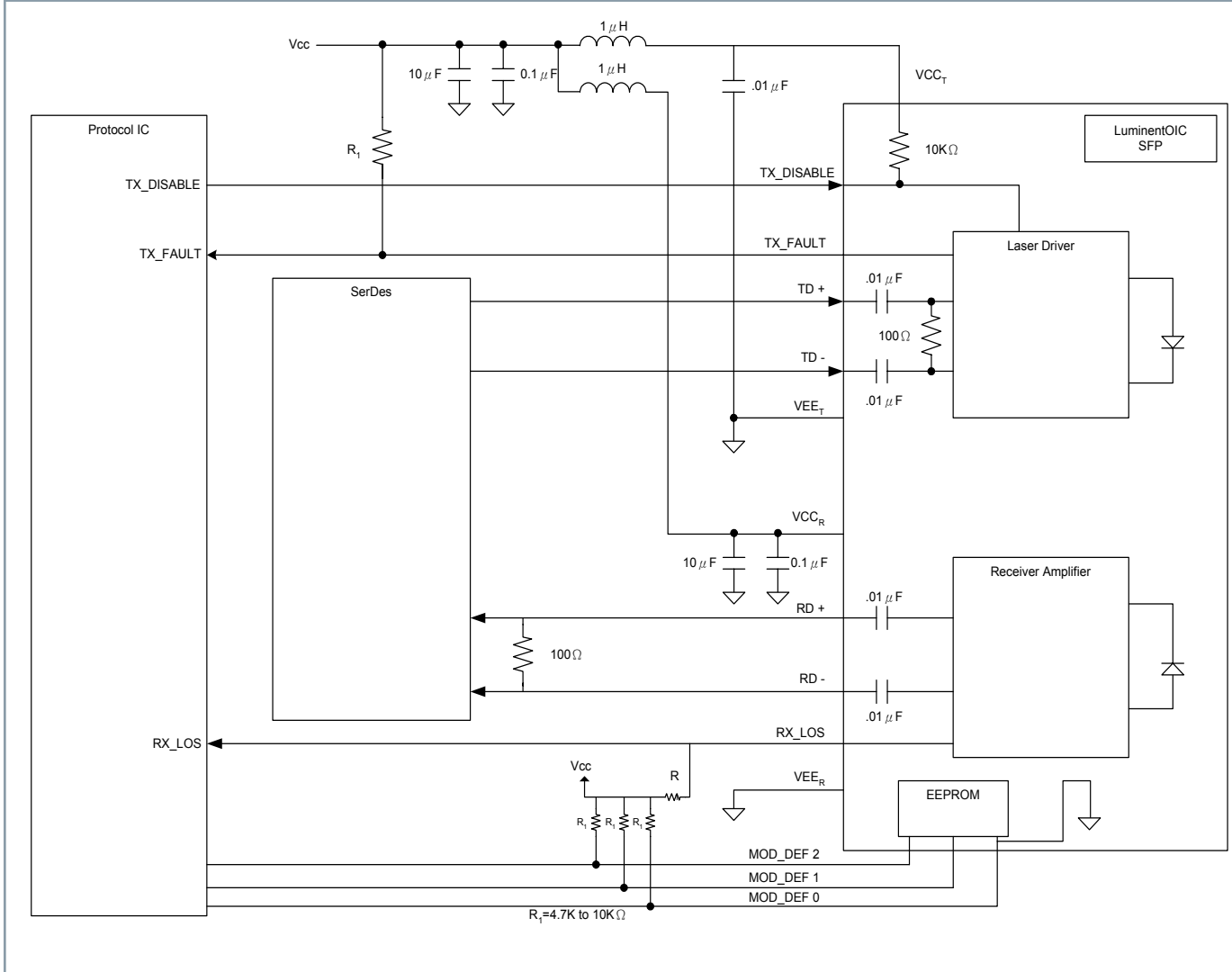

SP-GB-ZX-xxA

Ordering Information

Available Options:

- SP-GB-ZX-CDA
- SP-GB-ZX-CNA
- SP-GB-ZX-TDA
- SP-GB-ZX-TNA
- SP-GB-ZX-RDA
- SP-GB-ZX-RNA

Part numbering Definition:

SP - GB - ZX - Temperature Diagnostic Revision

- SP = Small Form Pluggable
- GB = 1.25 Gbps
- ZX = 1550 nm, 80 km
- Operating Temperature
- C = Commercial (-5 to 70°C)
- R = Reduced (-20 to 85°C)
- T = Industrial (-40 to 85°C)
- D = Digital Diagnostic (SFF-8472)
- N = No Digital Diagnostic
- Design Revision
- RoHS compliant

Warnings:

**Handling Precautions:** This device is susceptible to damage as a result of electrostatic discharge (ESD). A static free environment is highly recommended. Follow guidelines according to proper ESD procedures.

**Laser Safety:** Radiation emitted by laser devices can be dangerous to human eyes. Avoid eye exposure to direct or indirect radiation.

Legal Notes:

**IMPORTANT NOTICE!**

All information contained in this document is subject to change without notice, at LuminentOIC's sole and absolute discretion. LuminentOIC warrants performance of its products to current specifications only in accordance with the company's standard one-year warranty; however, specifications designated as "preliminary" are given to describe components only, and LuminentOIC expressly disclaims any and all warranties for said products, including express, implied, and statutory warranties, warranties of merchantability, fitness for a particular purpose, and non-infringement of proprietary rights. Please refer to the company's Terms and Conditions of Sale for further warranty information.

LuminentOIC assumes no liability for applications assistance, customer product design, software performance, or infringement of patents, services, or intellectual property described herein. No license, either express or implied, is granted under any patent right, copyright, or intellectual property right, and LuminentOIC makes no representations or warranties that the product(s) described herein are free from patent, copyright, or intellectual property rights. Products described in this document are NOT intended for use in implantation or other life support applications where malfunction may result in injury or death to persons. LuminentOIC customers using or selling products for use in such applications do so at their own risk and agree to fully defend and indemnify LuminentOIC for any damages resulting from such use or sale.

THE INFORMATION CONTAINED IN THIS DOCUMENT IS PROVIDED ON AN "AS IS" BASIS. Customer agrees that LuminentOIC is not liable for any actual, consequential, exemplary, or other damages arising directly or indirectly from any use of the information contained in this document. Customer must contact LuminentOIC to obtain the latest version of this publication to verify, before placing any order, that the information contained herein is current.

© LuminentOIC, Inc. 2003  
All rights reserved