

**PLEASE CHECK WWW.MOLEX.COM FOR LATEST PART INFORMATION**

**Part Number:** [0008500108](#)  
**Status:** **Active**  
**Overview:** [kk](#)  
**Description:** 3.96mm (.156") Pitch KK® Crimp Terminal 2578, 22-26 AWG, Bag, Brass, Tin (Sn)

**Documents:**

[Drawing \(PDF\)](#) [RoHS Certificate of Compliance \(PDF\)](#)  
[Product Specification PS-08-50 \(PDF\)](#)

**General**

Product Family	Crimp Terminals
Series	<a href="#">2578</a>
Crimp Quality Equipment	Yes
Overview	<a href="#">kk</a>
Product Name	KK®

**Physical**

Gender	Female
Material - Metal	Brass
Material - Plating Mating	Tin
Material - Plating Termination	Tin
Packaging Type	Bag
Plating min: Mating (µin)	100
Plating min: Mating (µm)	2.50
Plating min: Termination (µin)	100
Plating min: Termination (µm)	2.50
Termination Interface: Style	Crimp or Compression
Wire Insulation Diameter	1.65mm (.065") max.
Wire Size AWG	22, 24, 26
Wire Size mm²	N/A

**Material Info**

Old Part Number	2578-(P909)L
-----------------	--------------

**Reference - Drawing Numbers**

Packaging Specification	PK-2759-001
Product Specification	PS-08-50
Sales Drawing	SD-2578

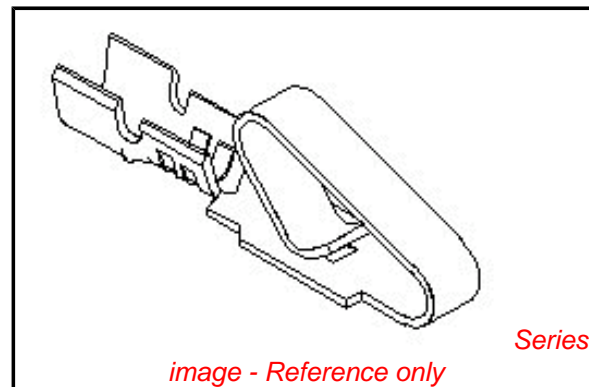

*image - Reference only*

**EU RoHS**

**ELV and RoHS  
Compliant**  
**REACH SVHC  
Contains SVHC: No**  
**Halogen-Free  
Status**

**China RoHS**



**Need more information on product  
environmental compliance?**

Email [productcompliance@molex.com](mailto:productcompliance@molex.com)  
 For a multiple part number RoHS Certificate of Compliance, [click here](#)

Please visit the [Contact Us](#) section for any non-product compliance questions.

**Search Parts in this Series**

[2578Series](#)

**Use With**

[2574](#) , [2139](#) , [41695](#) , [3069](#) , [6422](#) , [5265](#) , [5239](#)

**Application Tooling | FAQ**

*Tooling specifications and manuals are found by selecting the products below. Crimp Height Specifications are then contained in the Application Tooling Specification document.*

**Global**

Description	Product #
HAND CRIMP TOOL	<a href="#">0638117400</a>
Extraction Tool	<a href="#">0011030016</a>

NOTES:

1. CRIMP ACCEPTS 22 TO 26 GA. WIRE WITH (.165)/.065 MAX INSULATION DIA.
2. DIMENSIONS GIVEN ACROSS CENTERLINES ARE SYMMETRICAL ABOUT THOSE CENTERLINES WITHIN HALF THE TOTAL TOLERANCE.
3. OPTIONAL DESIGN (.86+.05)/.034+.002
4. TERMINAL CONFORMS TO PRODUCT SPEC. 08-50.
5. CAT EAR OPTION TO BE USED WITH 41695 HOUSING ONLY.

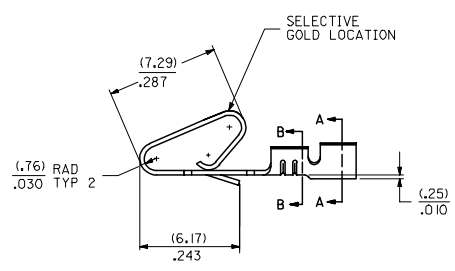
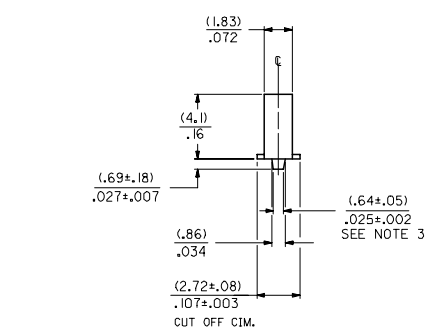
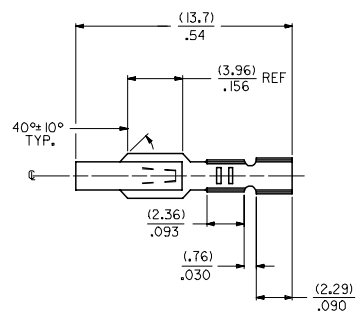
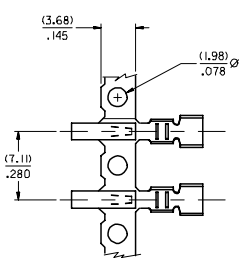
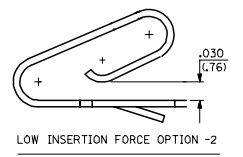
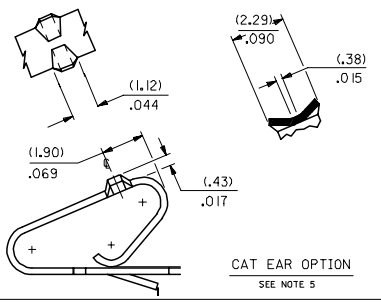

2578 - \* - \* \* \*  
 MATERIAL CODE  
 (.28)/.0106 THK  
 BLANK=BRASS  
 B=PHOS BRONZE  
 WINDING SPEC.  
 A=PER ES-339-A  
 BLANK=PER ES-339-B  
 L=LOOSE  
 PLATING CODE  
 (PER SDES-88)  
 \* (P909) OVERALL HOT TIN DIP: 2.54 MICROMETERS MIN  
 (550) SELECT GOLD: 0.38 MICROMETERS MIN.  
 OVERALL GOLD FLASH: 0.05 MICROMETERS MIN.  
 OVERALL NICKEL UNDERPLATE: 0.76 MICROMETERS MIN.  
 (555) SELECT GOLD: 0.38 MICROMETERS MIN.  
 OVERALL NICKEL UNDERPLATE: 0.76 MICROMETERS MIN.  
 OPTIONS  
 BLANK=AS SHOWN  
 1=WITH CAT EARS  
 2=LOW INSERTION FORCE

\*THE PRIMARY SHIPPING CARTON WILL BE LABELED \*COMPLIANT TO ROHS DIRECTIVE 2002/95/EC AND ELV ANNEX II OF DIRECTIVE 2000/53/EC.\* CARTONS WITHOUT THIS LABEL MAY CONTAIN PRODUCT WITH TIN-LEAD PLATING.

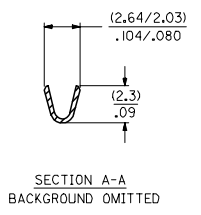
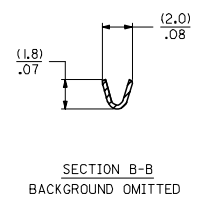

ENTER DESCRIPTION EC NO: UCP2005-0928 DRAWN BY: DRW:ADRIANO CHKD-SAMEC 2004/11/02 APPR:MMRIGALLIS 2004/11/02 W	QUALITY SYMBOLS	GENERAL TOLERANCES (UNLESS SPECIFIED)		DIMENSION STYLE IN/MM		SCALE	DESIGN UNITS INCH	THIRD ANGLE PROJECTION
	▽=0	4 PLACES ± --- ± ---	mm	INCH	DRAWN BY DATE	TITLE CRIMP TERMINAL (.96)/.156 CENTERS 22 TO 26 GA WIRE MOLEX INCORPORATED MATERIAL NO. SD-2578 DOCUMENT NO. SD-2578 SHEET NO. 1 OF 2	THIS DRAWING CONTAINS INFORMATION THAT IS PROPRIETARY TO MOLEX INCORPORATED AND SHOULD NOT BE USED WITHOUT WRITTEN PERMISSION	
	▽=0	3 PLACES ± --- ± .010			CHECKED BY DATE			
		2 PLACES ± 0.25 ± .014			APPROVED BY DATE			
	1 PLACE ± 0.36 ± ---			LENZ 01/29/87				
	ANGULAR ±1/2°	DRAFT WHERE APPLICABLE MUST REMAIN WITHIN DIMENSIONS		SEE CHART				

2578-(***)*		2578-B-(***)*		2578-B-2(***)*							
PART NO.	ENG. NO.	PART NO.	ENG. NO.	PART NO.	ENG. NO.	PART NO.	ENG. NO.	PART NO.	ENG. NO.	PART NO.	ENG. NO.
08-50-0107	2578-(P909)	08-56-0121	2578-B-(501)		2578-B-2(P909)						
08-50-0108	2578-(P909)L	08-56-0122	2578-B-(501)L		2578-B-2(P909)L						
08-50-0111	2578-(109)	08-50-0133 *	2578-B-(P909)		2578-B-2(555)						
08-50-0112	2578-(109)L	08-50-0134 *	2578-B-(P909)L		2578-B-2(555)L						
08-56-0107	2578-(550)	08-65-0116 *	2578-B-(555)		2578-B-2(550)						
08-56-0108	2578-(550)L	08-65-0117 *	2578-B-(555)L		2578-B-2(550)L						
08-55-0105	2578-(555)	08-65-0108	2578-B-(591)								
08-56-0106	2578-(555)L	08-65-0107	2578-B-(591)L								
08-59-0101	2578-(122)	08-60-0003	2578-B-(122)								
	2578-(122)L	08-60-0004	2578-B-(122)L								
1 08-56-0162	2578-(505)	08-65-0110	2578-B-(558)								
1 08-56-0163	2578-(505)L	08-65-0111	2578-B-(558)L								
08-50-0504	2578-(128)	08-58-0125 *	2578-B-(550)								
	2578-(128)L	08-58-0126 *	2578-B-(550)L								
08-56-0161	2578-(503)										
	2578-(503)L										
1 08-50-0061	2578-(224)										
1 08-50-0062	2578-(224)L										
1 08-50-0065	2578-(P224)										
1 08-50-0066	2578-(P224)L										
08-55-0137	2578-(558)A										
	2578-(558)L										
08-50-0018	2578-(102)										
08-50-0019	2578-(102)L										
08-55-0121	2578-(561)										
08-55-0132	2578-(561)L										
08-55-0123	2578-(558)										
	2578-(558)L										
08-65-0109	2578-(555)A										
08-52-0116	2578-(P909)										
08-52-0117	2578-(P9109)L										

<b>CHANGE TO ME10</b> EC NO: UCP2005-0928 DRAWN: DRATINDOL 2004/11/16 CHKD: SAMEC 2004/11/02 APPR: MARGULLIS 2004/11/02 W	<b>QUALITY SYMBOLS</b> ▽=0 ▽=0 DESCRIPTION	<b>GENERAL TOLERANCES (UNLESS SPECIFIED)</b>		<b>DIMENSION STYLE</b> IN/MM		SCALE	DESIGN UNITS INCH	<input checked="" type="checkbox"/> THIRD ANGLE PROJECTION
		4 PLACES ± --- ± --- 3 PLACES ± --- ± --- 2 PLACES ± --- ± --- 1 PLACE ± --- ± ---	mm INCH	DRAWN BY PEREZ/AR	DATE 01/29/87	TITLE CRIMP TERMINAL (3,96)/.156 CENTERS 22 TO 26 GA WIRE		
		ANGULAR ±1/2°		CHECKED BY PATEL	DATE 01/29/87	MOLEX INCORPORATED		
		DRAFT WHERE APPLICABLE MUST REMAIN WITHIN DIMENSIONS		APPROVED BY LENZ	DATE 01/29/87	MATERIAL NO. SEE CHARTS	DOCUMENT NO. SD-2578	SHEET NO. 2

THIS DRAWING CONTAINS INFORMATION THAT IS PROPRIETARY TO MOLEX INCORPORATED AND SHOULD NOT BE USED WITHOUT WRITTEN PERMISSION