

Features & Benefits

- Fully compatible with IBM ESCON* architecture
- Positive latching mechanism
- Self aligning and free floating ferrule design
- Zirconia ceramic ferrules - Pre-radiused and pre-polished
- Polarized housing with retractable shroud
- Low insertion loss: < .15 dB TYP

Applications

- Fiber optic link IBM ESCON networks
- Peripheral control units
- Storage devices
- Processors
- Workstations

The Enterprise Systems CONnection (ESCON) architecture was developed for high speed communication between mainframes and storage devices, peripheral control units, cluster controllers and other networks. Molex's ESCON series of connectors are fully compatible with the requirements of this architecture.

The connector is designed using the latest engineered polymer and ceramic materials featuring pre-radiused and pre-polished zirconia ceramic PC ferrules and a rugged polymer housing with a retractable shroud. Molex's unique termination process and the factory polished and radiused ferrules combine to produce quick and consistent ESCON terminations.

Adapters are available in either flange or snap-in mounting styles. Precision zirconia ceramic or polymer alignment sleeves can be provided with either mounting style.

*ESCON is a registered trademark of International Business Machines Corporation.

Optical Performance Distribution

Insertion Loss Performance
(MM enhanced ferrule, 62.5/125µm fiber)

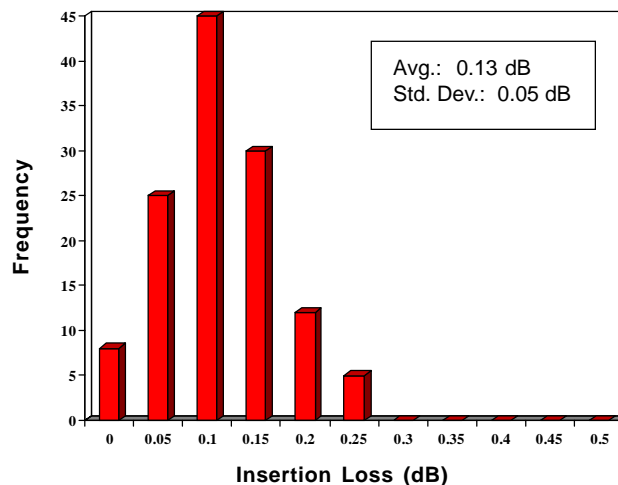

Performance and Specifications

Characteristics	Units	Min.	Typ.	Max.	Comments
Durability	~dB	-	-	0.07	FOTP-21, 100 mate/unmate cycles
Humidity Cycling	~dB	-	-	0.13	FOTP-5, type 1A, +60°C at 95% RH for 240 hours
Temperature Cycling	~dB	-	-	0.21	FOTP-3, modified to 2500 cycles 10°C to 60°C, max ramp, zero dwell time
Cable Retention	~dB	-	-	0.16	FOTP-6, modified to 8 cycles at 1 m and 3 m 133 N ramp and hold 5 seconds
Coupling Strength/Axial Pull	~dB	-	-	0.04	FOTP-185, 20 lb., hold 30 seconds
Impact	~dB	-	-	0.05	FOTP-2A, 8 cycles
Flex	~dB	-	-	0.05	FOTP-1, 1 lb. +/- 45°, 300 times
Twist	~dB	-	-	0.10	FOTP-36A, 10 lb. at 0.1 m +/- 180°
Vibration	~dB	-	-	0.11	FOTP-11, 10 to 55 Hz, 2 hours per axis
Insertion/Withdrawl force	lb				5.3 Insertion 0.6 Withdrawl

Mechanical Dimensions

ESCON Connector

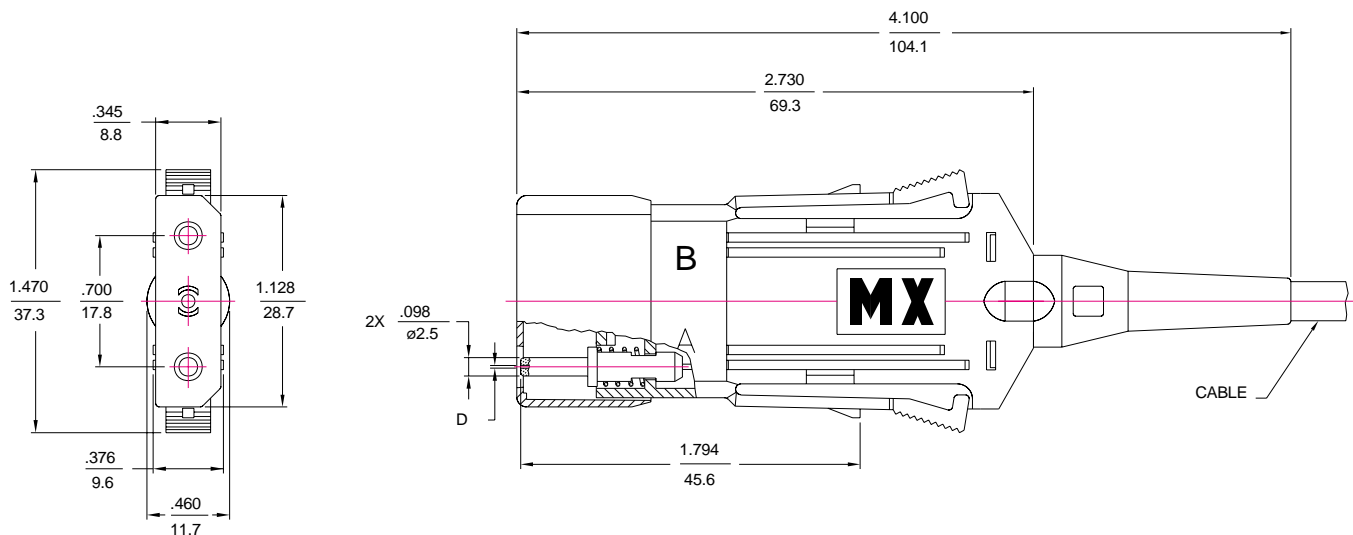

Mechanical Dimensions

ESCON Adapter, Snap-In Mount Style

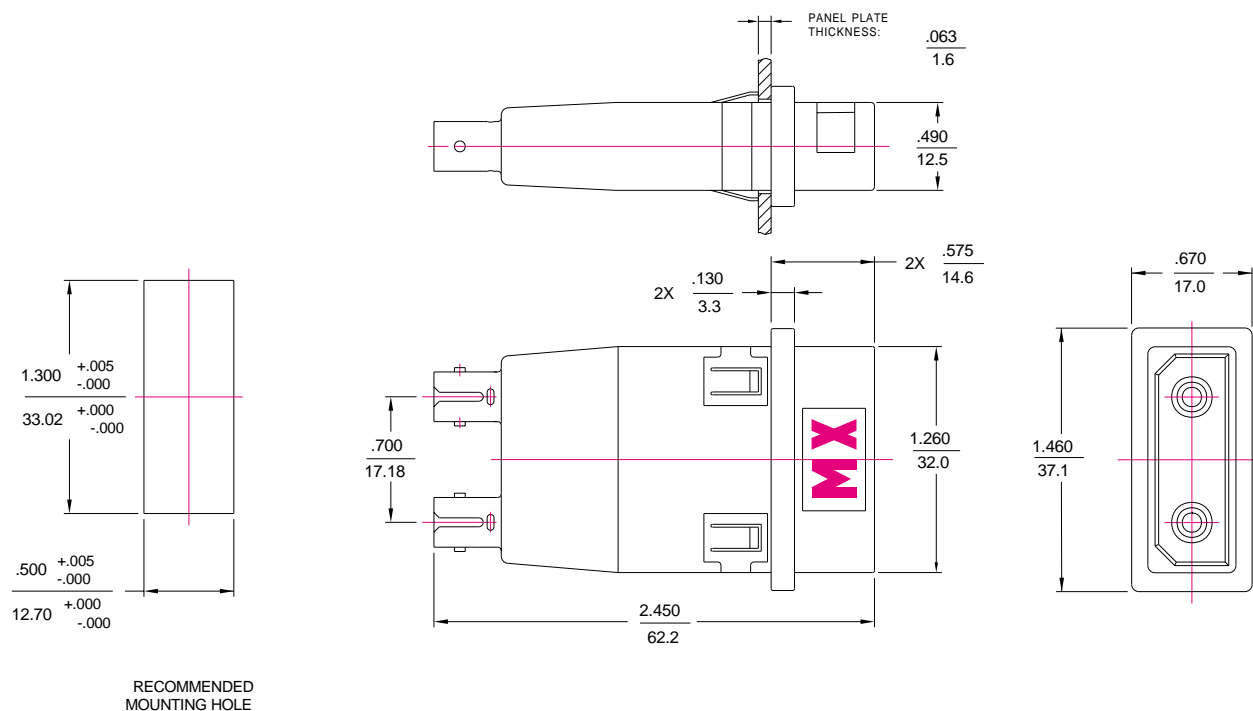

ESCON Adapter, Flange Mount Style

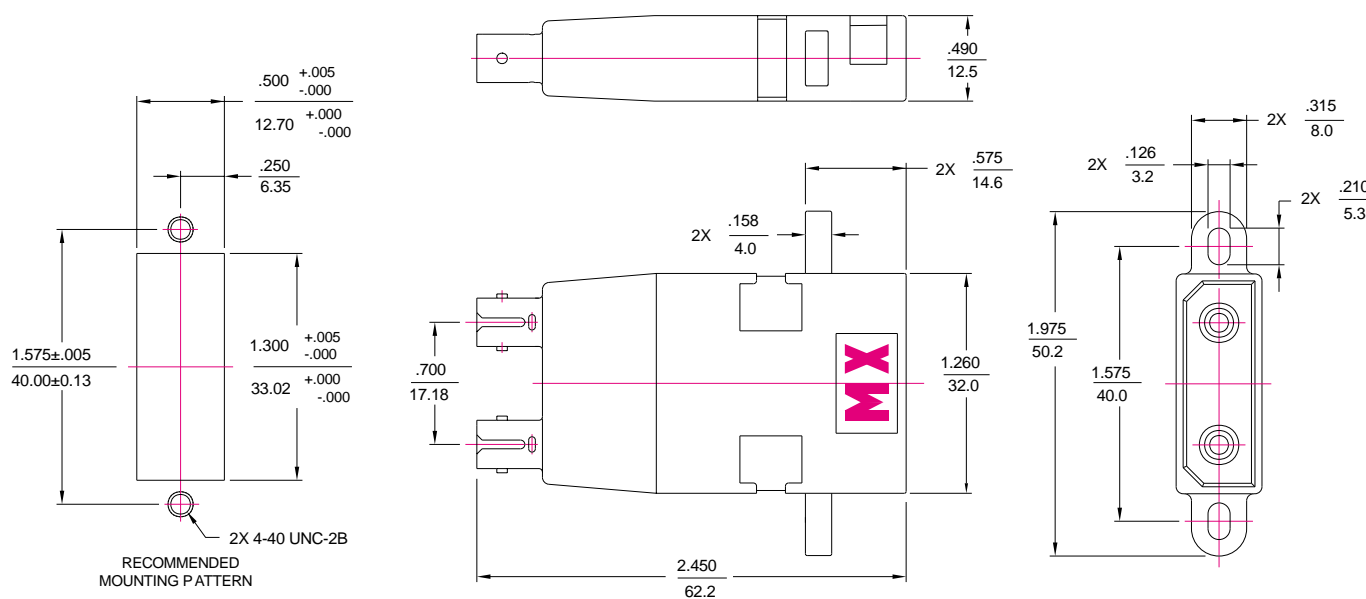

Mechanical Dimensions

ESCON-ESCON Adapter, Snap Mount

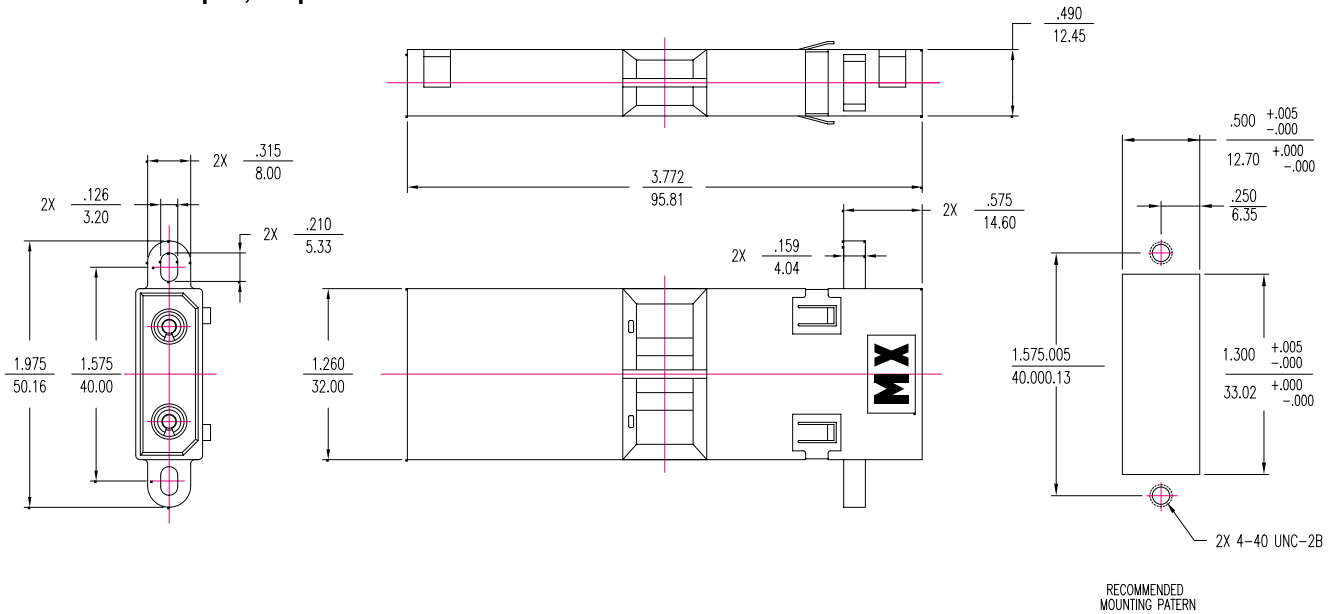

All dimensions in **INCHES**
mm

Standard Part Numbers

Order Number	Description	Hole size "D"	Cable size
86040-0100	ESCON connector, MM, zirconia PC* ferrule	127µm	4.8mm
86040-0200	ESCON connector, MM, zirconia PC* ferrule	127µm	zipcord
86040-3100	ESCON connector, MM, zirconia PC ferrule, enhanced	128µm	4.8mm
86040-3200	ESCON connector, MM, zirconia PC ferrule, enhanced	128µm	zipcord
86140-0000	ESCON-ST adapter, zirconia alignment sleeve, snap-in mount style		
86140-0300	ESCON-ST adapter, zirconia alignment sleeve, flange mount style		
86143-0000	ESCON-ST adapter, polymer alignment sleeve, snap-in mount style		
86143-0300	ESCON-ST adapter, polymer alignment sleeve, flange mount style		
86140-2300	ESCON-ESCON adapter, ceramic sleeve, flange mount style		
86142-2300	ESCON-ESCON adapter, phosphor bronze sleeve, flange mount style		
86140-2400	ESCON-ESCON adapter, ceramic sleeve, flange or snap mount style		
86142-2400	ESCON-ESCON adapter, phosphor bronze sleeve, flange or snap mount style		