

PLEASE CHECK WWW.MOLEX.COM FOR LATEST PART INFORMATION

Part Number: [0901481112](#)
Status: **Active**
Overview: [cgrid_sl_products](#)
Description: 2.54mm (.100") Pitch C-Grid® PC Board Connector, Single Row, Right Angle, 1.0µm (40µ") Tin (Sn), 12 Circuits

Documents:

[3D Model](#) [RoHS Certificate of Compliance \(PDF\)](#)
[Drawing \(PDF\)](#)

Agency Certification

CSA LR19980
 UL E29179

General

Product Family PCB Receptacles
 Series [90148](#)
 Application Board-to-Board
 Overview [cgrid_sl_products](#)
 Product Name C-Grid®

Physical

Circuits (Loaded) 12
 Circuits (maximum) 12
 Color - Resin Black
 Durability (mating cycles max) 30
 Flammability 94V-0
 Glow-Wire Compliant No
 Guide to Mating Part No
 Keying to Mating Part None
 Lock to Mating Part No
 Material - Metal Phosphor Bronze
 Material - Plating Mating Tin
 Material - Plating Termination Tin
 Material - Resin Polyester
 Number of Rows 1
 Orientation Right Angle
 PC Tail Length (in) 0.114 In
 PC Tail Length (mm) 2.90 mm
 PCB Locator No
 PCB Retention None
 PCB Thickness Recommended (in) 0.062 In
 PCB Thickness Recommended (mm) 1.60 mm
 Packaging Type Tube
 Pitch - Mating Interface (in) 0.100 In
 Pitch - Mating Interface (mm) 2.54 mm
 Pitch - Term. Interface (in) 0.100 In
 Pitch - Term. Interface (mm) 2.54 mm
 Plating min: Mating (µin) 40
 Plating min: Mating (µm) 1.00
 Plating min: Termination (µin) 40
 Plating min: Termination (µm) 1.00
 Polarized to Mating Part Yes
 Polarized to PCB No
 Stackable No
 Surface Mount Compatible (SMC) No

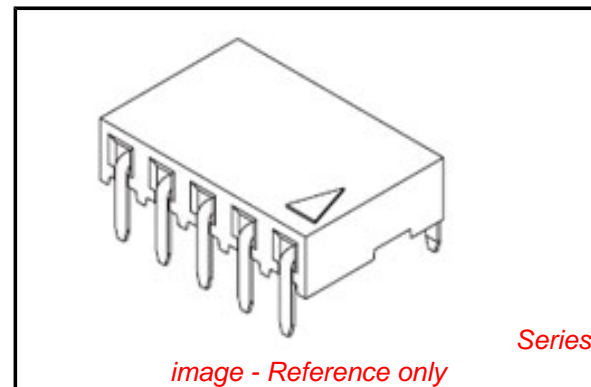

EU RoHS

ELV and RoHS Compliant
REACH SVHC Contains SVHC: No
Halogen-Free
Status Not Reviewed

China RoHS



Need more information on product environmental compliance?

Email productcompliance@molex.com
 For a multiple part number RoHS Certificate of Compliance, [click here](#)

Please visit the [Contact Us](#) section for any non-product compliance questions.

Search Parts in this Series

[90148Series](#)

Mates With

C-Grid III™ Header [90120](#) , [90121](#)

Temperature Range - Operating -55°C to +125°C
Termination Interface: Style Through Hole

Electrical

Current - Maximum per Contact 3A
Grounding to PCB No
Voltage - Maximum 350V AC/DC

Solder Process Data

Lead-free Process Capability Wave Capable (TH only)
Process Temperature max. C 260

Material Info

Reference - Drawing Numbers

Sales Drawing SDA-90148

This document was generated on 05/22/2010

PLEASE CHECK WWW.MOLEX.COM FOR LATEST PART INFORMATION

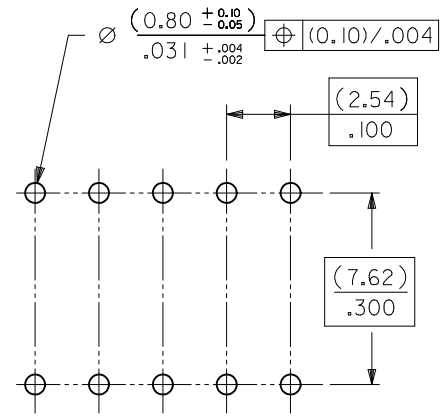
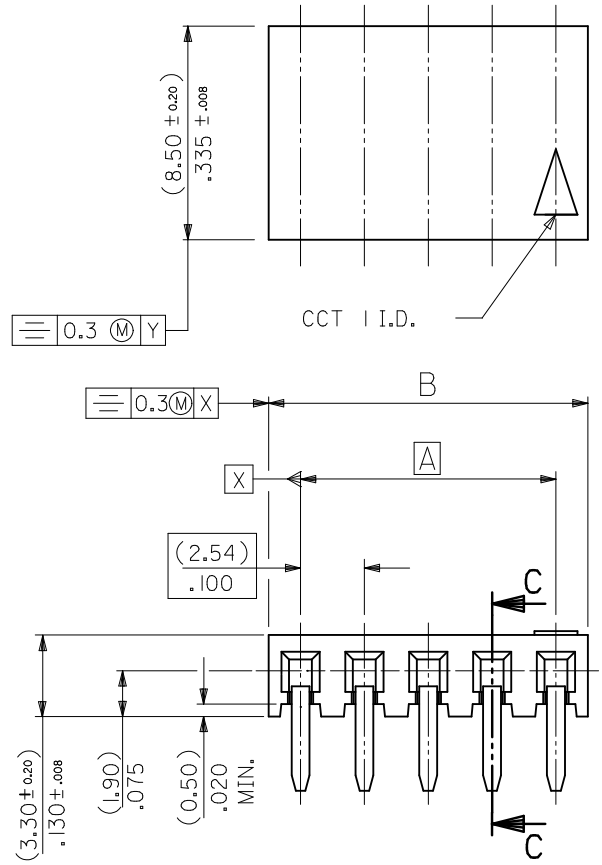

RECOMMENDED P.C. BOARD HOLE PATTERN FOR STRAIGHT PINS

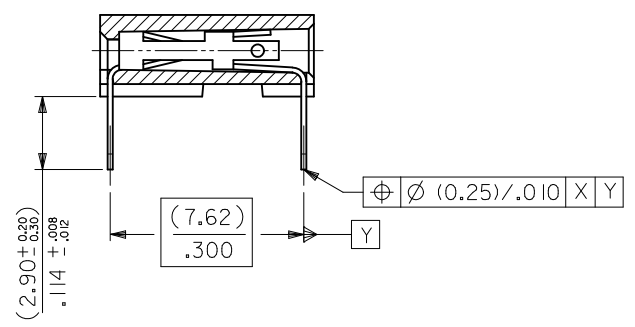

SECTION C-C SHOWING STRAIGHT PINS

NOTES

- 1) CONTACT-PLATED PHOSPHOR BRONZE.
(SEE SHEET 2)
- 2) HOUSING
POLYESTER (PBT), 15% GLASS FILL, UL94-V0.
COLOR: BLACK.
ALSO
POLYAMIDE (PA4/6), 30% GLASS FILL, UL94-V0.
COLOR: NATURAL.
- 3) FOR (0.635)±.025 SQ. MALE PINS THE LENGTH MUST BE (5.65)±.222 MIN & (7.00)±.276 MAX. TO ENSURE GOOD CONNECTION WITH CONTACT.
- 4) PRODUCT SPECIFICATION: PS-99020-0001
- 5) PCB THICKNESS 1.6MM

| | | | | | | | | | | |
|---|--|--|--|--------------------------|----------------------------|---|---------------------------|------------------------|------------------------|--|
| UPDATE TOL. SYMMETRY EC NO: S2010-0968 DRWN:SKANG CHKD:ATSEE APPR:MLONG | 2010/05/26 2010/06/04 2010/06/05 | QUALITY SYMBOLS $F_{A/0}$ $F_{B/0}$ $F_{C/0}$ | GENERAL TOLERANCES (UNLESS SPECIFIED) | | DIMENSION STYLE MM ONLY | | SCALE NTS | DESIGN UNITS METRIC | THIRD ANGLE PROJECTION | |
| | | | mm INCH | DRAWN BY DB | DATE 1987/07/14 | TITLE C-GRID III SINGLE ROW HORIZONTAL P.C BOARD CONN. | | | | |
| | | | 4 PLACES ± --- ± --- 3 PLACES ± --- ± --- 2 PLACES ± 0.15 ± --- 1 PLACE ± --- ± --- | CHECKED BY D.MORIARTY | DATE 2005/03/02 | MOLEX INCORPORATED | | | | |
| | | | ANGULAR ± 2 ° | APPROVED BY J.DENNEHY | DATE 2010/06/04 | MATERIAL NO. SEE TABLE | DOCUMENT NO. SDA-90148 | SHEET NO. 1 OF 3 | | |
| DRAFT WHERE APPLICABLE MUST REMAIN WITHIN DIMENSIONS | | | THIS DRAWING CONTAINS INFORMATION THAT IS PROPRIETARY TO MOLEX INCORPORATED AND SHOULD NOT BE USED WITHOUT WRITTEN PERMISSION | | | | | | | |

| PART NO's - STRAIGHT PINS | | PART NO. | NO OF CKTS. | DIM. A | | DIM. B ^(+0.30) _{-0.02} | | NO. PER TUBE | |
|---------------------------|-------------------|------------|-------------|-----------|-----------|--|-----------|--------------|----|
| STANDARD | CUSTOMER SPECIFIC | | | | | | | | |
| 90148-1X02 | | 90148-4X02 | 2 | (2.54) | .100 | (5.08) | .200 | 105 | |
| ↑ | ↑ 03 | ↑ | ↑ 03 | 3 | (5.08) | .200 | (7.62) | .300 | 72 |
| | 04 | | 04 | 4 | (7.62) | .300 | (10.16) | .400 | 52 |
| | 05 | | 05 | 5 | (10.16) | .400 | (12.70) | .500 | 44 |
| | 06 | 90148-9X06 | 06 | 6 | (12.70) | .500 | (15.24) | .600 | 36 |
| | 07 | | 07 | 7 | (15.24) | .600 | (17.78) | .700 | 30 |
| | 08 | | 08 | 8 | (17.78) | .700 | (20.32) | .800 | 26 |
| | 09 | | 09 | 9 | (20.32) | .800 | (22.86) | .900 | 24 |
| | 10 | | 10 | 10 | (22.86) | .900 | (25.40) | 1.000 | 22 |
| | 11 | | 11 | 11 | (25.40) | 1.000 | (27.94) | 1.100 | 18 |
| | 12 | | 12 | 12 | (27.94) | 1.100 | (30.48) | 1.200 | 18 |
| | 13 | | 13 | 13 | | | | | 16 |
| | 14 | | 14 | 14 | (33.02) | 1.300 | (35.56) | 1.400 | 14 |
| | 15 | | 15 | 15 | (35.56) | 1.400 | (38.10) | 1.500 | 14 |
| | 16 | | 16 | 16 | | | | | 13 |
| | 17 | | 17 | 17 | | | | | 12 |
| | 18 | | 18 | 18 | (43.18) | 1.700 | (45.72) | 1.800 | 12 |
| | 19 | | 19 | 19 | (45.72) | 1.800 | (48.26) | 1.900 | 12 |
| | 20 | | 20 | 20 | (48.26) | 1.900 | (50.80) | 2.000 | 11 |
| | 21 | | 21 | 21 | | | | | 10 |
| | 22 | | 22 | 22 | | | | | 10 |
| | 23 | | 23 | 23 | | | | | 10 |
| | 24 | | 24 | 24 | | | | | 9 |
| | 25 | | 25 | 25 | (60.96) | 2.400 | (63.50) | 2.500 | 8 |
| | 26 | | 26 | 26 | (63.50) | 2.500 | (66.04) | 2.600 | 8 |
| | 27 | | 27 | 27 | | | | | 8 |
| | 28 | | 28 | 28 | | | | | 7 |
| | 29 | | 29 | 29 | | | | | 7 |
| | 30 | | 30 | 30 | (73.66) | 2.900 | (76.20) | 3.000 | 7 |
| | ↓ 31 | | ↓ 31 | 31 | | | | | 7 |
| 90148-1X32 | | 90148-4X32 | 32 | (78.74) | 3.100 | (81.28) | 3.200 | 6 | |

PLATING VERSION A

PRE-PLATED HOT DIP TIN

1.0 TO 2.5 microns (.00004" TO .00010").

PLATING VERSION E

1.27 TO 1.78 microns (.00005" TO .00007") NICKEL

OVERALL, 0.38 TO 0.64 microns (.000015" TO .000025")

GOLD ON CONTACT AREA (OVER NICKEL).

3 TO 5 microns (.00012" TO .00020") TIN

ON SOLDER TAILS (OVER NICKEL).

PLATING VERSION F.

1.27 TO 1.78 microns (.00005" TO .00007") NICKEL

OVERALL, 0.76 TO 1.0 microns (.00003" TO .00004")

GOLD ON CONTACT AREA (OVER NICKEL).

3 TO 5 microns (.00012" TO .00020") TIN

ON SOLDER TAILS (OVER NICKEL).

90148-XXYY

INDICATES NO. OF CIRCUITS

PLATING CODE

1 = VERSION A

2 = VERSION E

3 = VERSION F

1 = STRAIGHT PINS POLYESTER

9 = STRAIGHT PINS POLYESTER

4 = STRAIGHT PINS NYLON 46

| | | | | | | | |
|--|-----------------|---------------------------------------|-----------------|---|--------------|--|--|
| UPDATE TOL. SYMMETRY EC NO: S2010-0968 DRWN:SKANG 2010/05/26 CHKD:ATSEE 2010/06/04 APPR:MLONG 2010/06/05 | QUALITY SYMBOLS | GENERAL TOLERANCES (UNLESS SPECIFIED) | DIMENSION STYLE | SCALE | DESIGN UNITS | THIRD ANGLE PROJECTION | |
| | | | MM ONLY | NTS | METRIC | | |
| | | | mm INCH | DRAWN BY | DATE | TITLE | |
| | | | | DB | 1987/07/14 | C-GRID III SINGLE ROW HORIZONTAL P.C BOARD CONN. | |
| | | | CHECKED BY | DATE | | | |
| | | | D.MORIARTY | 2005/03/02 | | | |
| | | | APPROVED BY | DATE | | | |
| | | | J.DENNEHY | 2010/06/04 | | | |
| | | | MATERIAL NO. | DOCUMENT NO. | | | |
| | | | SEE TABLE | | SDA-90148 | | |
| | | | SIZE | THIS DRAWING CONTAINS INFORMATION THAT IS PROPRIETARY TO MOLEX INCORPORATED AND SHOULD NOT BE USED WITHOUT WRITTEN PERMISSION | | | |
| | | | A3 | | | | |

| PART NO. | POLARISED CCT NO. | NO. OF CKTS. | DIM. A | DIM. B (± 0.30) (± 0.012) | NO. PER TUBE |
|------------|-------------------|--------------|---------------|--|--------------|
| 90148-3X01 | 2 | 3 | (5.08) .200 | (7.62) .300 | 72 |

NON-STANDARD PRODUCTS

90148-XXYY
 ——— OPTION NUMBER
 (NOT RELATING TO CCT SIZE OR OTHERWISE)
 ——— PLATING CODE (SEE SHEET 2)
 ——— 3 = STRAIGHT PINS POLYESTER, POLARISED

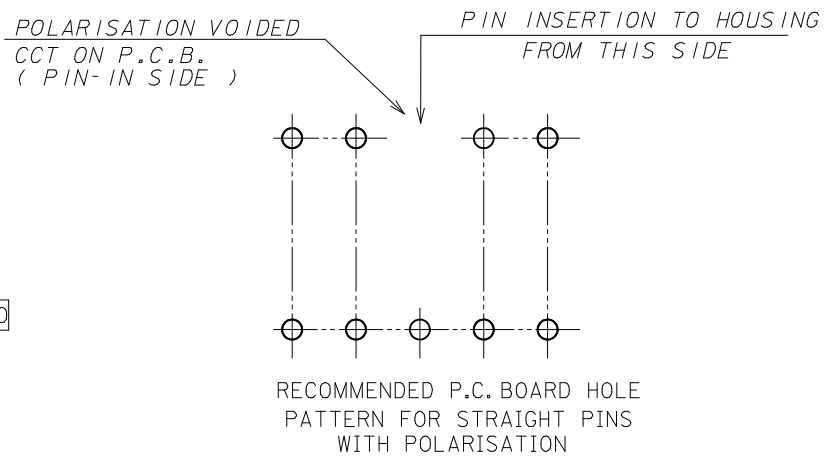
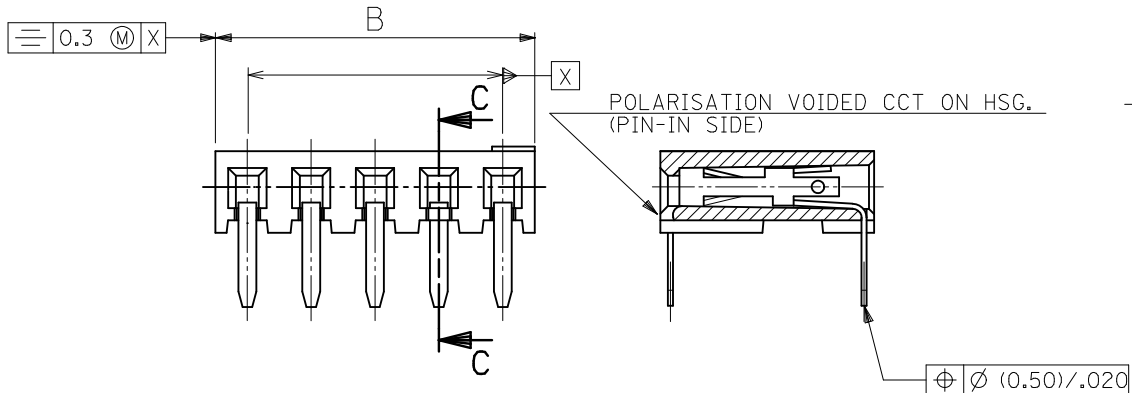

NOTES
 1) SEE SHEET 1 FOR ALL UNSPECIFIED DIMENSIONS AND NOTES.
 2) PARTS NOT STACKABLE.

| | | | | | | | | |
|--|-----------|---|-----------------|---------------------------------------|---|------------------|--|------------------------|
| UPDATE TOL. SYMMETRY EC NO: SZ010-0968 DRWN: SKANG CHKD: ATSEE APPR: MLONG | REV AK | DESCRIPTION 2010/05/26 2010/06/04 2010/06/05 | QUALITY SYMBOLS | GENERAL TOLERANCES (UNLESS SPECIFIED) | DIMENSION STYLE | SCALE | DESIGN UNITS | THIRD ANGLE PROJECTION |
| | | | $\nabla F=0$ | 4 PLACES | MM ONLY | NTS | METRIC | |
| | | | $\nabla F=0$ | 3 PLACES | | | | |
| | | | $\nabla F=0$ | 2 PLACES | | | | |
| | | | 1 PLACE | ANGULAR $\pm 2^\circ$ | DRAWN BY: DB | DATE: 1987/07/14 | TITLE: C-GRID III SINGLE ROW HORIZONTAL P.C. BOARD CONN. | |
| | | | | | CHECKED BY: D. MORIARTY | DATE: 2005/03/02 | MOLEX INCORPORATED | |
| | | | | | APPROVED BY: J. DENNEHY | DATE: 2010/06/04 | SDA-90148 | |
| | | | | | MATERIAL NO. | DOCUMENT NO. | SHEET NO. | |
| | | | | | SEE TABLE | | 3 OF 3 | |
| | | | | | THIS DRAWING CONTAINS INFORMATION THAT IS PROPRIETARY TO MOLEX INCORPORATED AND SHOULD NOT BE USED WITHOUT WRITTEN PERMISSION | | | |

| PART NO's - STRAIGHT PINS | | PART NO. | NO OF CKTS. | DIM. A | DIM. B $(\pm \frac{0.30}{.32})$ | NO. PER TUBE |
|---------------------------|-------------------|------------|-------------|---------------|---------------------------------|--------------|
| STANDARD | CUSTOMER SPECIFIC | | | | | |
| 90148-1X02 | | 90148-4X02 | 2 | (2.54) .100 | (5.08) .200 | 105 |
| ↑ 03 | ↑ | ↑ 03 | 3 | (5.08) .200 | (7.62) .300 | 72 |
| 04 | ↓ | 04 | 4 | (7.62) .300 | (10.16) .400 | 52 |
| 05 | | 05 | 5 | (10.16) .400 | (12.70) .500 | 44 |
| 06 | 90148-9X06 | 06 | 6 | (12.70) .500 | (15.24) .600 | 36 |
| 07 | | 07 | 7 | (15.24) .600 | (17.78) .700 | 30 |
| 08 | | 08 | 8 | (17.78) .700 | (20.32) .800 | 26 |
| 09 | | 09 | 9 | (20.32) .800 | (22.86) .900 | 24 |
| 10 | | 10 | 10 | (22.86) .900 | (25.40) 1.000 | 22 |
| 11 | | 11 | 11 | (25.40) 1.000 | (27.94) 1.100 | 18 |
| 12 | | 12 | 12 | (27.94) 1.100 | (30.48) 1.200 | 18 |
| 13 | | 13 | 13 | | | 16 |
| 14 | | 14 | 14 | (33.02) 1.300 | (35.56) 1.400 | 14 |
| 15 | | 15 | 15 | (35.56) 1.400 | (38.10) 1.500 | 14 |
| 16 | | 16 | 16 | | | 13 |
| 17 | | 17 | 17 | | | 12 |
| 18 | | 18 | 18 | (43.18) 1.700 | (45.72) 1.800 | 12 |
| 19 | | 19 | 19 | (45.72) 1.800 | (48.26) 1.900 | 12 |
| 20 | | 20 | 20 | (48.26) 1.900 | (50.80) 2.000 | 11 |
| 21 | | 21 | 21 | | | 10 |
| 22 | | 22 | 22 | | | 10 |
| 23 | | 23 | 23 | | | 10 |
| 24 | | 24 | 24 | | | 9 |
| 25 | | 25 | 25 | (60.96) 2.400 | (63.50) 2.500 | 8 |
| 26 | | 26 | 26 | (63.50) 2.500 | (66.04) 2.600 | 8 |
| 27 | | 27 | 27 | | | 8 |
| 28 | | 28 | 28 | | | 7 |
| 29 | | 29 | 29 | | | 7 |
| 30 | | 30 | 30 | (73.66) 2.900 | (76.20) 3.000 | 7 |
| ↓ 31 | ↓ | ↓ 31 | 31 | | | 7 |
| 90148-1X32 | | 90148-4X32 | 32 | (78.74) 3.100 | (81.28) 3.200 | 6 |

PLATING VERSION A

PRE-PLATED HOT DIP TIN
1.0 TO 2.5 microns (.00004" TO .00010").

PLATING VERSION E

1.27 TO 1.78 microns (.00005" TO .00007") NICKEL
OVERALL, 0.38 TO 0.64 microns (.000015" TO .000025")
GOLD ON CONTACT AREA (OVER NICKEL).
3 TO 5 microns (.00012" TO .00020") TIN
ON SOLDER TAILS (OVER NICKEL).

PLATING VERSION F.

1.27 TO 1.78 microns (.00005" TO .00007") NICKEL
OVERALL, 0.76 TO 1.0 microns (.00003" TO .00004")
GOLD ON CONTACT AREA (OVER NICKEL).
3 TO 5 microns (.00012" TO .00020") TIN
ON SOLDER TAILS (OVER NICKEL).

90148-XXXX

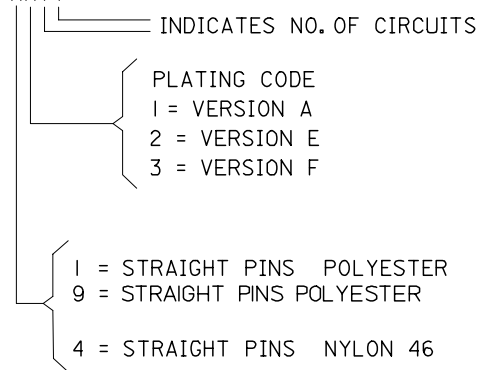

| | | | | | | | |
|--|-----------------|--|---|----------------|------------------------|--|---------------------|
| ADD NEW P/N EC NO: E2007-0823 DRWN:DBYRNES CHKD: APPR:EDMAMONY 2007/03/29 2007/03/29 2007/04/04 | QUALITY SYMBOLS | GENERAL TOLERANCES (UNLESS SPECIFIED) | DIMENSION STYLE MM ONLY | SCALE --- | DESIGN UNITS METRIC | THIRD ANGLE PROJECTION | |
| | ▽=0 ▽C=0 | 4 PLACES ±--- ±--- 3 PLACES ±--- ±--- 2 PLACES ±--- ±--- 1 PLACE ±--- ±--- ANGULAR ±---° | mm INCH | DRAWN BY DB | DATE 1987/07/14 | TITLE C-GRID III SINGLE ROW HORIZONTAL P.C. BOARD CONNECTOR | |
| | | DRAFT WHERE APPLICABLE MUST REMAIN WITHIN DIMENSIONS | APPROVED BY J.DENNEHY | DATE | MATERIAL NO. | DOCUMENT NO. SDA-90148 | SHEET NO. 2 OF 3 |
| | AJ | SIZE A3 | THIS DRAWING CONTAINS INFORMATION THAT IS PROPRIETARY TO MOLEX INCORPORATED AND SHOULD NOT BE USED WITHOUT WRITTEN PERMISSION | | | | |