

D-Sub Connectors Solder Cup Termination

17JE Series

DDK Ltd.



Conforming
Standard
MIL-DTL-24308

FEATURES

- Solder-cup termination contact for manual soldering.
- Number of contact is 9, 15, 25 and 37.
- Stranded cable AWG22 is applicable to this connector. Please use the soldering iron of 40W (max.)
- The metal shell is in Nickel plating. The pin connectors of metal shell are beat-finished.
- Connection of cable and plug can be shielded by the metalize-finished hood, improving resistance against EMI shield.

SPECIFICATIONS

Rated Voltage	300V AC (r.m.s.)
Rated Current	5A / Contact
Dielectric Withstanding Voltage	1000V AC (r.m.s.) / 1 minute
Insulation Resistance	1000M Ω (min.) at 500V DC
Contact Resistance	10m Ω (max.)
Applicable Cable	Solid Cable AWG20(max.), Stranded Cable AWG22(max.)
Operating Temperature	-25°C ~ 85°C

MATERIAL / FINISH



Item	Material / Finish
Insulator	PBT Resin (UL94V-0) / White
Shell	Steel / Ni Plating
Contact	Copper Alloy / Au over Ni Plating
Hood	ABS Resin / Ni Plating
Lock Screw	Steel or Copper Alloy / Ni Plating

© Specifications and/or dimensions in this catalog are subject to change without notice.
Please verify the latest specifications with our drawings.

▶ Solder Cup Termination Connector

17JE-13250-02(D1)A

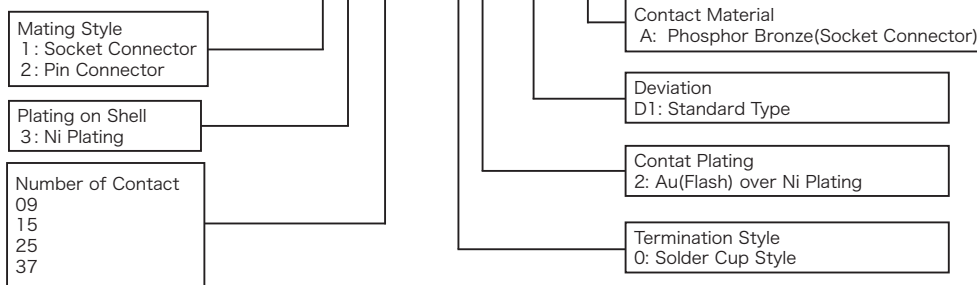

17JE-13 □□ 0-02(D1)A

Socket Connector

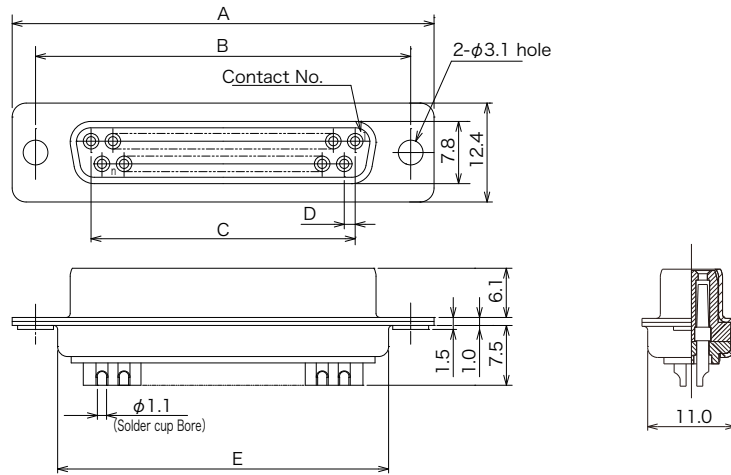

17JE-23 □□ 0-02(D1)

Pin Connector

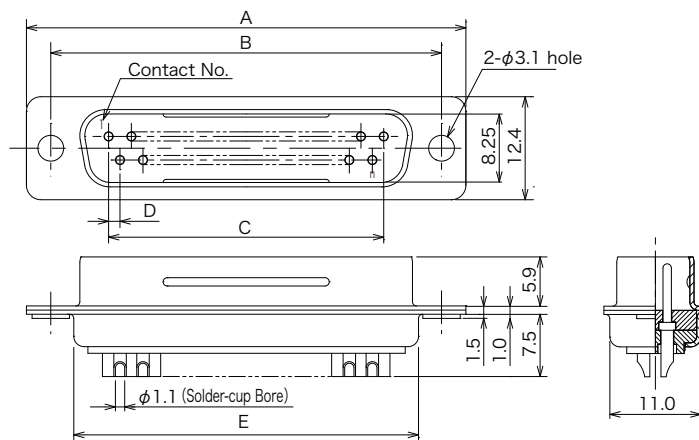

Number of Contact	Part Number		A	B	C	D	E
	Socket Connector	Pin Connector					
9	17JE-13090-02(D1)A	17JE-23090-02(D1)	30.70	24.99	10.98	1.37	19.50
15	17JE-13150-02(D1)A	17JE-23150-02(D1)	39.00	33.32	19.20	1.37	27.75
25	17JE-13250-02(D1)A	17JE-23250-02(D1)	52.90	47.04	33.12	1.38	41.50
37	17JE-13370-02(D1)A	17JE-23370-02(D1)	69.20	63.50	49.66	1.38	57.95

© Specifications and/or dimensions in this catalog are subject to change without notice.
Please verify the latest specifications with our drawings.

D-Sub Connectors with Cable Hood Kit

Connector with Cable Hood Kit

EMI Shielded

17JE-13250-02(D8Ax)A-CG

Mating Style

- 1: Socket Connector (for Standard Cable)
- 2: Pin Connector (for Standard Cable)
- 3: Socket Connector (for Slim Cable)
- 4: Pin Connector (for Slim Cable)

Plating on Shell

3: Ni Plating

Number of Contact

09, 15, 25, 37

Termination

0: Solder-cup

Contact Plating

2: Au(Flash) over Ni Plating

Lead and Cadmium Free

A-CG : Lead and Cadmium Free (Socket Connector)
 -CG : Lead and Cadmium Free (Pin Connector)

Deviation

D8 A x

Lock Screw
 No Digit : Standard
 2, 6 : Refer to page 7

Thread
 A : M2.6x0.45
 B : M3x0.5
 C : # 4-40UNC

Straight Hood
 Nickel Plating Metarised-finish

Socket Connector

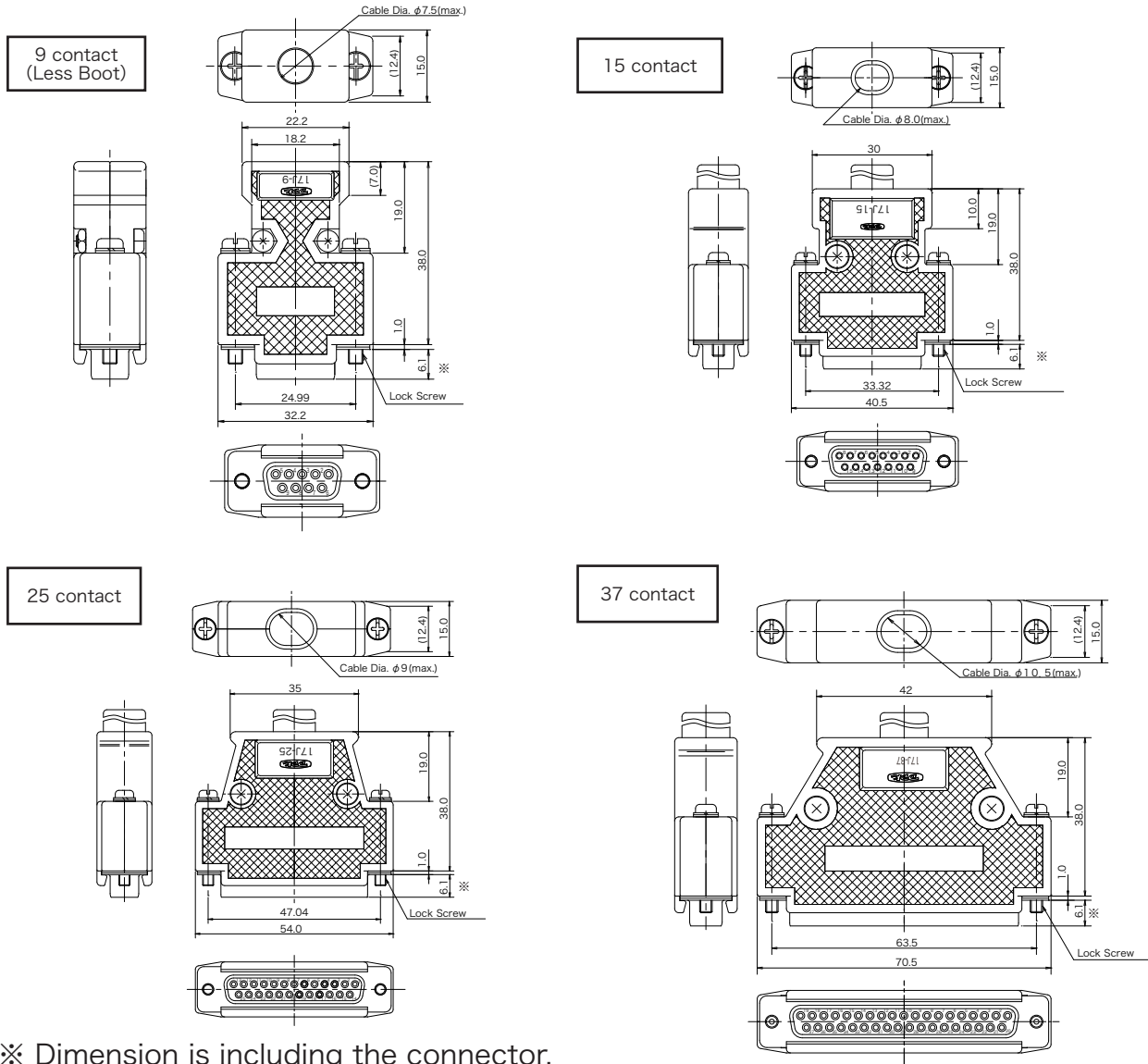

© Specifications and/or dimensions in this catalog are subject to change without notice.
 Please verify the latest specifications with our drawings.

▶ D-Sub Connector with Cable Hood Kit

Pin Connector 17JE-23xx0-02(D8xx)-CG

9 contact
(Less Boot)

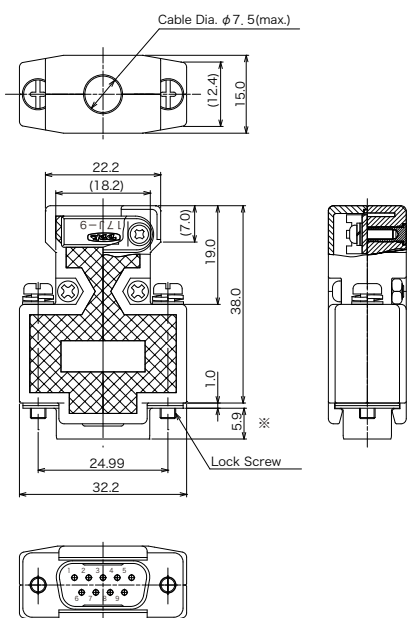

15 contact

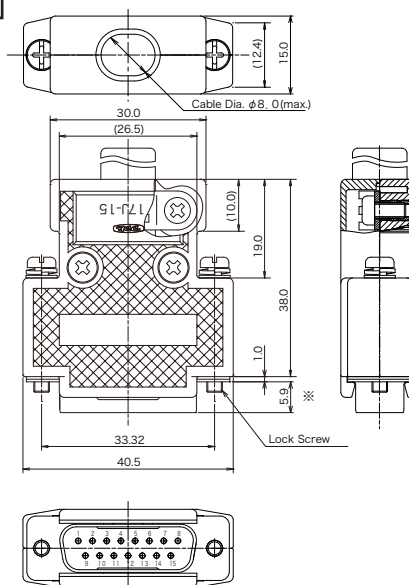

25 contact

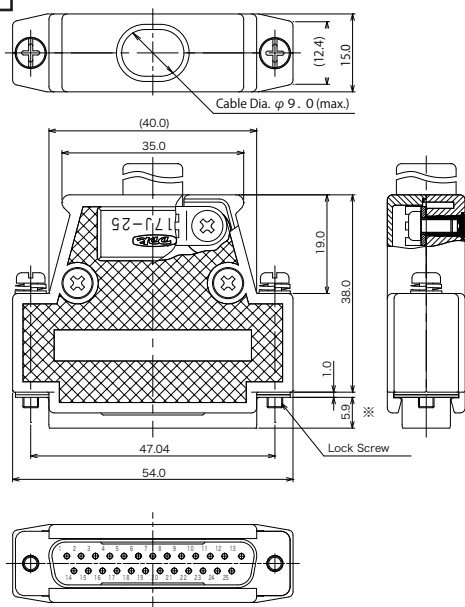

37 contact

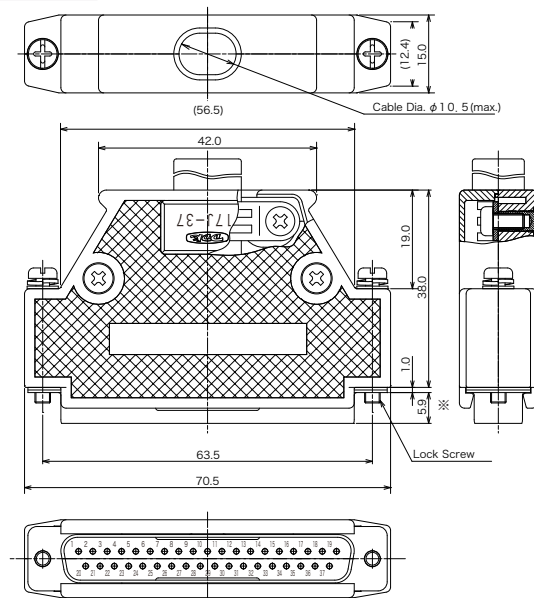

※ Dimension is including the connector.

© Specifications and/or dimensions in this catalog are subject to change without notice.
Please verify the latest specifications with our drawings.

▶ Panel Mount Deviation

Deviation of Panel Mount

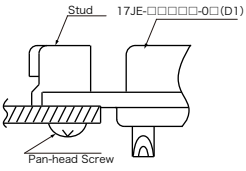
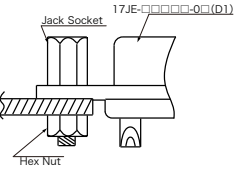
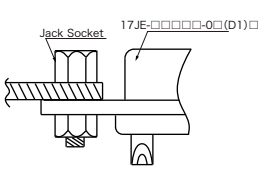
Mounting Style	Front Mount	Front Mount	Rear Mount
Stud Jack Socket			
17L-002 □ Type 1	Assembled with Stud , Pan-head Screw Socket 17JE-13 □ □ 0-0 □ (D2 □)-CG Pin 17JE-23 □ □ 0-0 □ (D2 □)-CG		
17L-003 □ 1 Type 2		Jack socket and hex nut(M3) are attached. • Socket 17JE-13 □ □ 0-0 □ (D3 □)A • Pin 17JE-23 □ □ 0-0 □ (D3 □)	
17L-003 □ 3 Type 3			Jack socket and hex nut(M3) are attached. • Socket 17JE-13 □ □ 0-0 □ (D4 □)A • Pin 17JE-23 □ □ 0-0 □ (D4 □)

□ : Thread Size A : M2.6×0.45 not available
 B : M3×0.5
 C : # 4-40UNC

● Panel Mounting Configuration

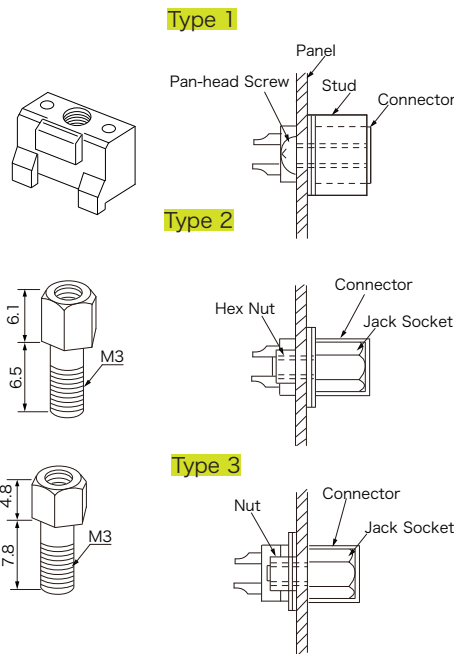

● Panel Cut-out Dimensions

Type 1 or Type 2

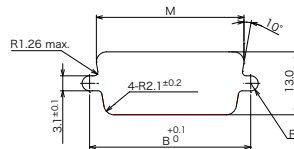

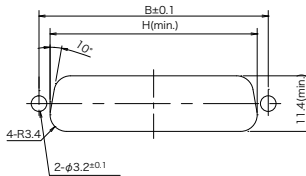

Type 3 ※ Connector can be fastened on the panel.
 (Panel Thickness : 0.8 ~ 1.3)



Number of Contact	B	H	M
9	24.99	20.5	22.2
15	33.32	28.8	30.5
25	47.04	42.5	44.3
37	63.50	59.1	60.7

© Specifications and/or dimensions in this catalog are subject to change without notice.
 Please verify the latest specifications with our drawings.

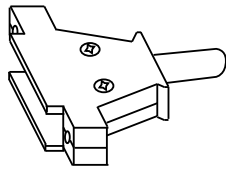
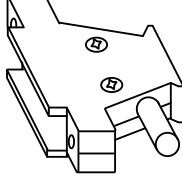
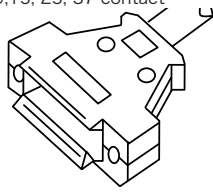
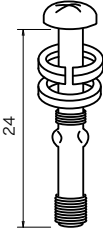
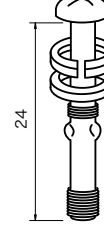
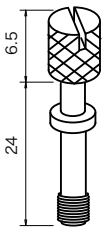
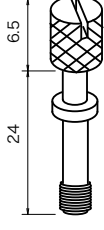
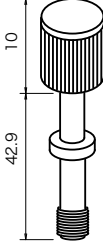
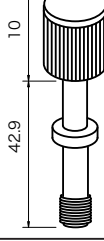
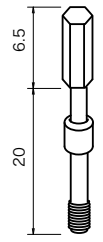
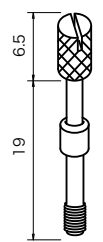
▶ Deviation List

Hood Lock Screw	Straight Hood for 9, 15, 25, 37 contact 	Right Angle Hood for 25 contact 	Hood Lock Screw	Straight Hood for Slim Cable 9,15, 25, 37 contact 															
<p>17J-001 □</p>  <p>24</p>	<p>Hood P/N: 17JE-25H-1A-CF 25 contact Thread Size: A</p> <p>Deviation: (D8 □) (※)</p> <ul style="list-style-type: none"> • Socket 17JE-13 □ □ 0-02(D8 □)A-CG • Pin 17JE-23 □ □ 0-02(D8 □)-CG 		<p>17J-001 □</p>  <p>24</p>	<p>Hood P/N: 17JE- □ □ H2- □ □ -CF</p> <p>Deviation: (D8 □) (※)</p> <ul style="list-style-type: none"> • Socket 17JE-33 □ □ 0-02(D8 □)A-CG • Pin 17JE-43 □ □ 0-02(D8 □)-CG 															
<p>17J-002 □</p>  <p>6.5 24</p>	<p>Hood P/N: 17JE- □ □ H-1 □ 2-CF</p> <p>Deviation: (D8 □ 2) (※)</p> <ul style="list-style-type: none"> • Socket 17JE-13 □ □ 0-02(D8 □ 2)A-CG • Pin 17JE-23 □ □ 0-02(D8 □ 2)-CG 		<p>17J-002 □</p>  <p>6.5 24</p>	<p>Hood P/N: 17JE- □ □ H2- □ □ 2-CF</p> <p>Deviation: (D8 □ 2) (※)</p> <ul style="list-style-type: none"> • Socket 17JE-33 □ □ 0-02(D8 □ 2)A-CG • Pin 17JE-43 □ □ 0-02(D8 □ 2)-CG 															
<p>17J-005 □ -CF</p>  <p>10 42.9</p>	<p>Hood P/N: 17JE- □ □ H-1 □ 4-CF</p> <p>Deviation: (D8 □ 6) (※)</p> <ul style="list-style-type: none"> • Socket 17JE-13 □ □ 0-02(D8 □ 6)A-CG • Pin 17JE-23 □ □ 0-02(D8 □ 6)-CG 		<p>17J-005 □ -CF</p>  <p>10 42.9</p>	<p>17JE- □ □ H2- □ □ 4-CF</p> <p>Deviation: (D8 □ 6) (※)</p> <ul style="list-style-type: none"> • Socket 17JE-33 □ □ 0-02(D8 □ 6)A-CG • Pin 17JE-43 □ □ 0-02(D8 □ 6)-CG 															
<p>17J-008 □ -CF</p>  <p>6.5 20</p>		<p>Hood P/N: 17JE-25LH-1 □ -CF</p> <p>Deviation: (D18 □) (※)</p> <ul style="list-style-type: none"> • Socket 17JE-13 □ □ 0-02(D18 □)A-CG • Pin 17JE-23 □ □ 0-02(D18 □)-CG 	<p>Applicable Cable Size</p> <table border="1" data-bbox="992 1453 1430 1637"> <thead> <tr> <th>Size</th> <th>Standard Cable</th> <th>Slim Cable</th> </tr> </thead> <tbody> <tr> <td>9</td> <td>φ 7.5 (max.)</td> <td>φ 5.1 (max.)</td> </tr> <tr> <td>15</td> <td>φ 8.0 (max.)</td> <td>φ 5.7 (max.)</td> </tr> <tr> <td>25</td> <td>φ 9.0 (max.)</td> <td>φ 6.6 (max.)</td> </tr> <tr> <td>37</td> <td>φ 10.5 (max.)</td> <td>φ 7.4 (max.)</td> </tr> </tbody> </table>		Size	Standard Cable	Slim Cable	9	φ 7.5 (max.)	φ 5.1 (max.)	15	φ 8.0 (max.)	φ 5.7 (max.)	25	φ 9.0 (max.)	φ 6.6 (max.)	37	φ 10.5 (max.)	φ 7.4 (max.)
Size	Standard Cable	Slim Cable																	
9	φ 7.5 (max.)	φ 5.1 (max.)																	
15	φ 8.0 (max.)	φ 5.7 (max.)																	
25	φ 9.0 (max.)	φ 6.6 (max.)																	
37	φ 10.5 (max.)	φ 7.4 (max.)																	
<p>17J-014 □ -CF</p>  <p>6.5 19</p>		<p>Hood P/N: 17JE-25LH-1 □ 1-CF</p> <p>Deviation: (D18 □ 1) (※)</p> <ul style="list-style-type: none"> • Socket 17JE-13 □ □ 0-02(D18 □ 1)A-CG • Pin 17JE-23 □ □ 0-02(D18 □ 1)-CG 																	

Thread Size
 A : M2.6×0.45
 B : M3×0.5
 C : # 4-40UNC

not available

(※) Connector with Hood Kit

© Specifications and/or dimensions in this catalog are subject to change without notice.
 Please verify the latest specifications with our drawings.