

# SDM2F150G04G

## Fast Soft Recovery Diode Module

### General Description

FRD module devices are optimized to reduce losses and EMI/RFI in high frequency power conditioning electrical systems.

These diode modules are ideally suited for power converters, motors drives and other applications where switching losses are significant portion of the total losses

### Features

- Repetitive Reverse Voltage :  $V_{RRM} = 400V$
- Low Forward Voltage Drop :  $V_F(\text{typ.}) = 1.25V$
- Average Forward Current :  $I_F(\text{AV.}) = 150A$  @  $T_C = 100^\circ C$
- Fast Reverse Recovery Time :  $t_{rr}(\text{typ.}) = 65 \text{ ns}$  @  $150A$
- Extensive Characterization of Recovery Parameters
- Reduced EMI and RFI
- Non Isolation Type Package
- $175^\circ C$  Operating Junction Temperature
- Dual FRD Construction

### Applications

- High Speed & High Power Converters, Welders.
- Various Switching and Telecommunication Power Supply.

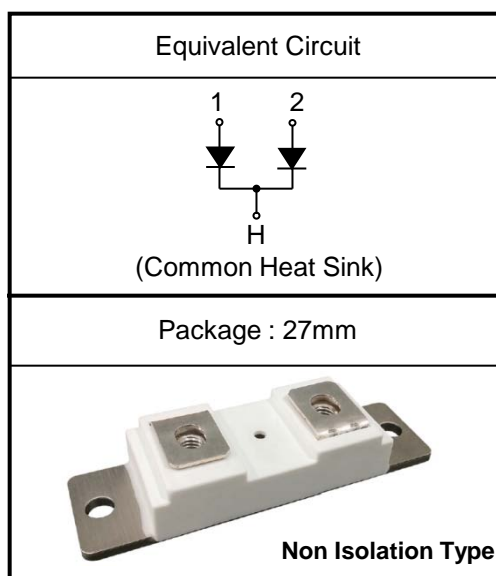

Please see the package Out line information

### Absolute Maximum Ratings @ $T_C=25^\circ C$ (Per Leg)

Symbol	Parameter	Value	Unit
$V_{RRM}$	Repetitive Peak Reverse Voltage	400	V
$V_R$	Reverse DC Voltage	320	V
$I_{F(AV)}$	Average Forward Current	$T_C = 100^\circ C$ , Per Diode	150
		$T_C = 100^\circ C$ , Per Module	300
$I_{FSM}$	No Repetitive Surge Forward Current (1/2 cycle, sine)	2750	A
$I^2t$	$I^2t$ For Fusing (60Hz, sine, $t=8.3\text{ms}$ , $T_J = 25^\circ C$ )	$31.3 * 10^3$	$A^2s$
$P_D$	Maximum Power Dissipation	620	W
$T_J$	Junction Temperature	-40 to +175	$^\circ C$
$T_{STG}$	Storage Temperature	-40 to +150	$^\circ C$

**Electrical Characteristics**  $T_C=25^\circ\text{C}$  unless otherwise specified

Symbol	Parameter	Test Conditions	Min	Typ	Max	Unit	
$V_R$	Cathode Anode Breakdown Voltage	$I_R = 100\mu\text{A}$	400	--	--	V	
$I_R$	Repetitive Peak Reverse Current	$V_R = 400\text{V}, T_C = 100^\circ\text{C}$	--	--	1	mA	
$V_{FM}$	Maximum Forward Voltage	$I_F = 150\text{A}$	$T_C = 25^\circ\text{C}$	--	1.25	1.5	V
			$T_C = 100^\circ\text{C}$	--	1.15	--	
$t_{rr}$	Reverse Recovery Time	$V_R = 30\text{V},$ $I_F = 1\text{A},$ $di/dt = -200\text{A}/\mu\text{s}$	$T_C = 25^\circ\text{C}$	--	45	60	ns
$t_{rr}$	Reverse Recovery Time	$V_R = 200\text{V},$ $I_F = 150\text{A},$ $di/dt = -200\text{A}/\mu\text{s}$	$T_C = 25^\circ\text{C}$	--	65	--	ns
			$T_C = 100^\circ\text{C}$	--	100	--	

**Thermal Mechanical Specifications**

Symbol	Parameter	Test Conditions	Min	Typ	Max	Unit
$R_{\theta JC}$	Thermal Resistance	Junction-to-Case	--	--	0.24	$^\circ\text{C}/\text{W}$
-	Torque	Mounting Torque (M6)	4.0			N·m
-	Torque	Terminal Torque (M6)	3.0			N·m
L x W x H	Dimensions	Typical, see outline drawing	92 x 27 x 17			mm
-		Term. To Term	--	35	--	mm
m	Mass		--	95	--	g

Characterization curves

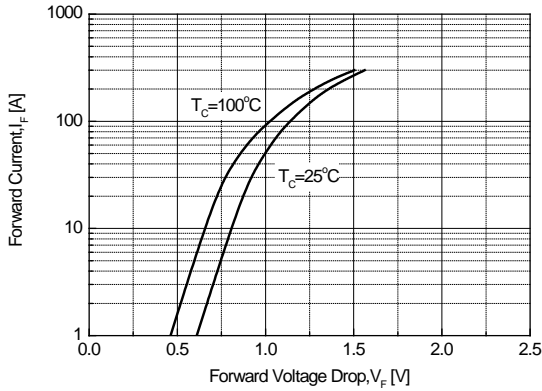

Figure 1. Typical Forward Voltage Drop vs. Instantaneous Forward Current

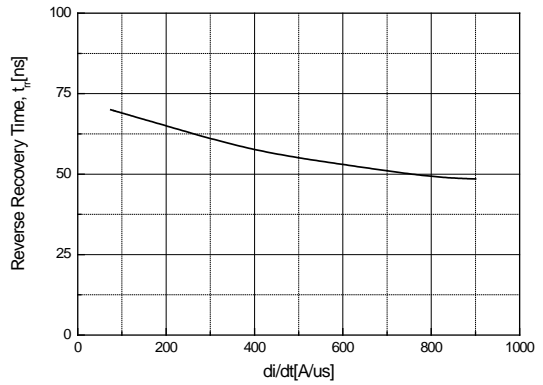

Figure 2. Typical Reverse Recovery Time vs.  $-di/dt$

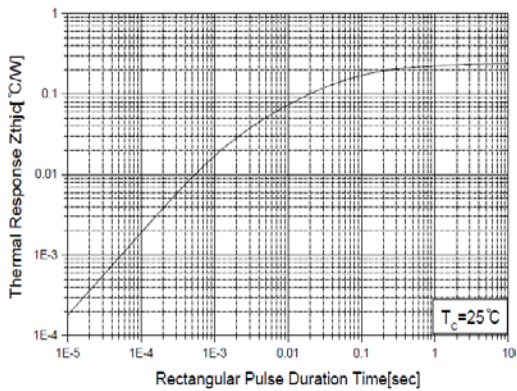

Figure 3. Transient Thermal Impedance ( $Z_{thjc}$ ) Characteristics

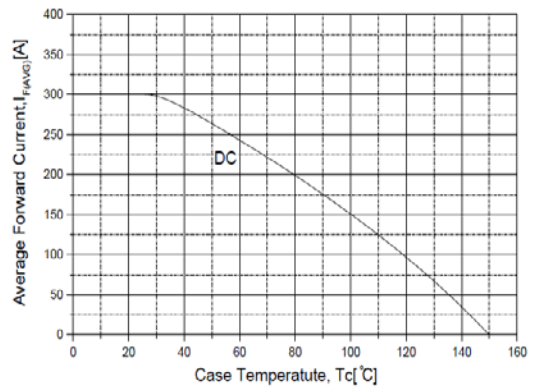

Figure 4. Forward Current Derating Curve

## Package Out line Information

27mm



Dimensions in mm

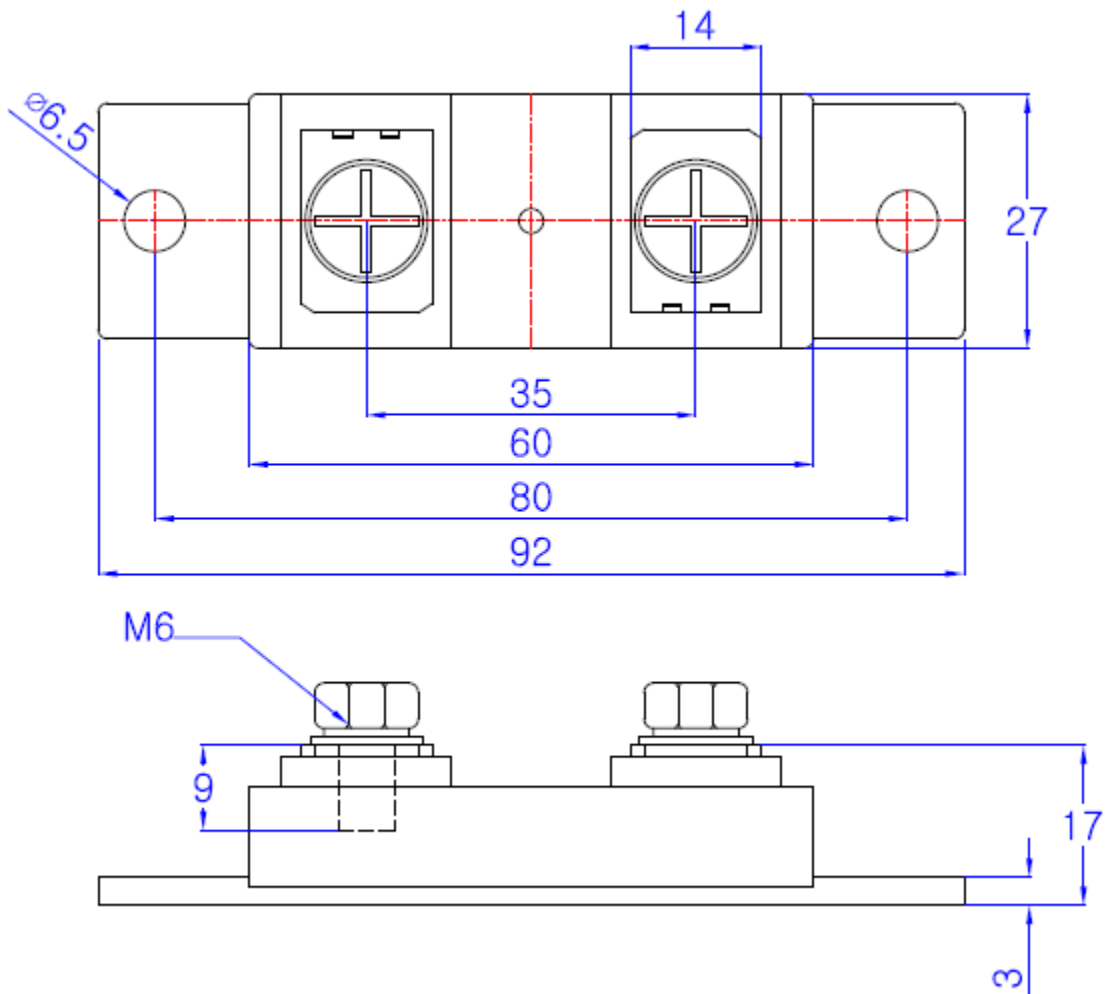

### Attached (recommended torque):

Mounting torque(M6) 4.0 Nm    Terminal torque(M6) 3.0 Nm