

THIS DRAWING IS UNPUBLISHED.

RELEASED FOR PUBLICATION

20

© COPYRIGHT 20

BY TYCO ELECTRONICS CORPORATION. ALL INTERNATIONAL RIGHTS RESERVED.

LOC GP DIST 00

REVISIONS

P	LTR	DESCRIPTION	DATE	DWN	APVD
	B	REVISED PER ECO-13-000397	31JAN2013	CJV	CWR

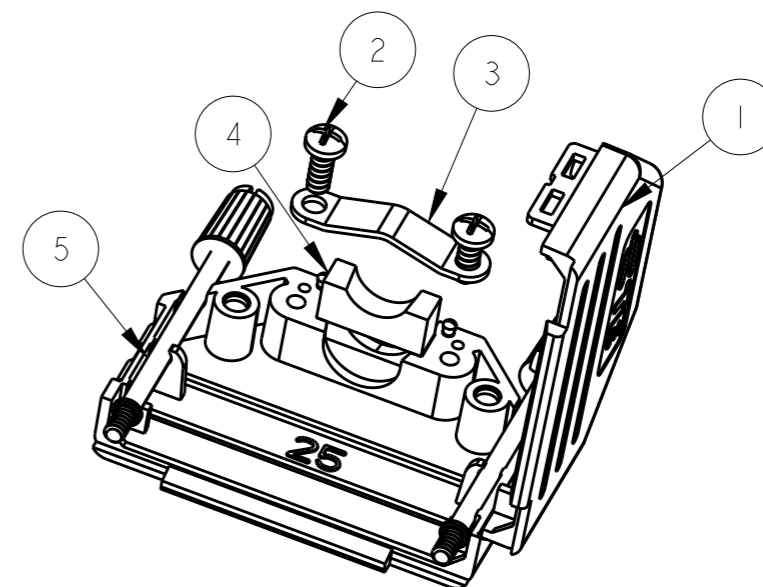
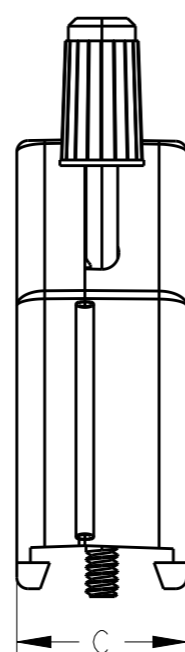
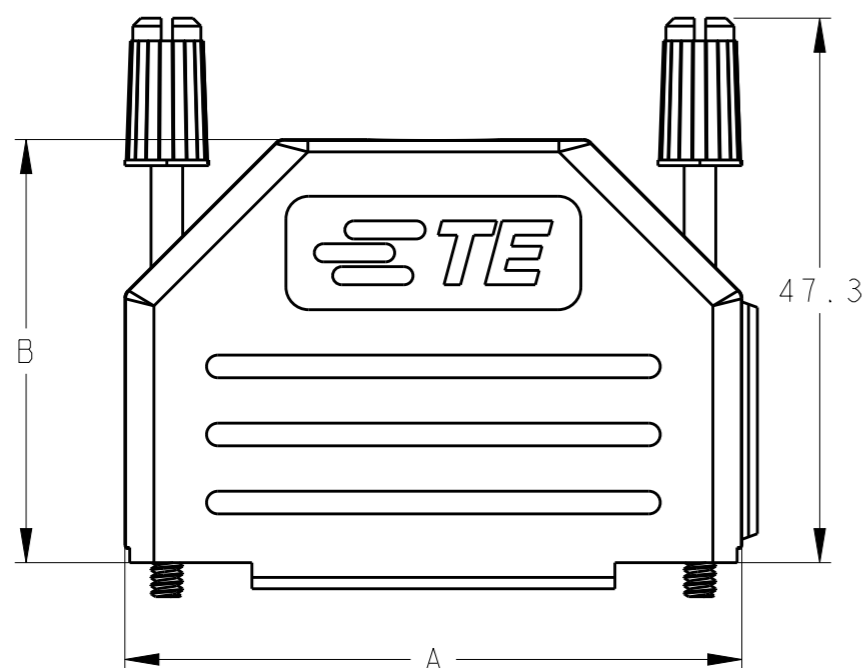

1 BULK PACKAGED SHELL ASSEMBLIES:
ITEMS 1 THRU 5, 100 TIMES QTY SHOWN
IN TABLE IN ONE BAG FOR EACH ITEM.
ALL BAGS IN ONE BOX.

2. TEMPERATURE RANGE -55C - +105C.

3. CABLE DIAMETER 3.0 - 11.0mm.

4 TRIVALENT CHROMIUM CHROMATE COATING
OVER ZINC PLATING.

	15.0	36.0	70.9	SELF TAPPING	4-40 UNC	4	37	BLACK	3-1991253-7
	15.0	37.3	54.4	SELF TAPPING	4-40 UNC	3	25	BLACK	2-1991253-5
	15.0	30.8	40.7	SELF TAPPING	4-40 UNC	2	15	BLACK	1-1991253-5
	15.0	31.3	32.4	SELF TAPPING	4-40 UNC	1	9	BLACK	1991253-9
PACKAGING	DIM C	DIM B	DIM A	FIXING SCREW TYPE	JACKSCREW THREAD	SHELL SIZE	POSITION	COLOUR	PART NO

5	JACKSCREW ASSEMBLY	POLYAMIDE UL94V2 (KNOB) CARBON STEEL (SHAFT)	BLACK 	2
4	CABLE CLAMP BASE	POLYAMIDE UL94 V2	BLACK	1
3	CABLE CLAMP	CARBON STEEL		1
2	FIXING SCREW	CARBON STEEL		2
1	BACKSHELL BODY	POLYAMIDE UL94 V2	BLACK	1
ITEM	DESCRIPTION	MATERIAL	FINISH	QTY

THIS DRAWING IS A CONTROLLED DOCUMENT FOR TYCO ELECTRONICS CORPORATION
IT IS SUBJECT TO CHANGE AND THE CONTROLLING ENGINEERING ORGANIZATION
SHOULD BE CONTACTED FOR THE LATEST REVISION.

DWN M. GREENER 05JAN2011

CHK J. AMBROSE 05JAN2011

APVD J. AMBROSE 05JAN2011

PRODUCT SPEC

APPLICATION SPEC

WEIGHT

CUSTOMER DRAWING



Tyco Electronics UK Ltd.
Bideford, North Devon, EX39 4HE

NAME
LOW COST PLASTIC
D-SUB BACKSHELL

SIZE CAGE CODE DRAWING NO RESTRICTED TO

A300779 G-1991253

SCALE NTS SHEET 1 OF 1 REV B

DIMENSIONS:		TOLERANCES UNLESS OTHERWISE SPECIFIED:	
mm			
	0 PLC	±0.5	
	1 PLC	±0.5	
	2 PLC	±0.5	
	3 PLC	±0.5	
	4 PLC	±0.5	
	ANGLES	±0.5	
MATERIAL SEE TABLE		FINISH -	