

## DRV8313 TRIPLE HALF-H-BRIDGE DRIVER IC

 Check for Samples: [DRV8313](#)

### FEATURES

- **Three Half-H-Bridge Driver IC**
  - **Drives 3-Phase Brushless DC Motors**
  - **Individual Half-Bridge Control**
  - **Pins for Low-Side Current Sensing**
  - **Low MOSFET On-Resistance**
- **2.5-A Maximum Drive Current at 24 V, 25°C**
- **Uncommitted Comparator Can Be Used for Current Limit or Other Functions**
- **Built-In 3.3-V 10-mA LDO Regulator**
- **8-V to 60-V Operating Supply Voltage Range**
- **Thermally Enhanced Surface-Mount Package**

### APPLICATIONS

- **HVAC Motors**
- **Consumer Products**
- **Office Automation Machines**
- **Factory Automation**
- **Robotics**

### DESCRIPTION

The DRV8313 provides three individually controllable half-H-bridge drivers. It is intended to drive a three-phase brushless dc motor, though it can also be used to drive solenoids or other loads. Each output driver channel consists of N-channel power MOSFETs configured in a half-H-bridge configuration. The design brings the ground terminals of each driver to pins, to allow one to perform current sensing on each output.

Current-limit circuitry or other functions are possible uses of an uncommitted comparator.

The DRV8313 can supply up to 2.5-A peak or 1.75-A rms output current per channel (with proper PCB heatsinking at 24 V and 25°C) per half-H-bridge.

The device provides internal shutdown functions for overcurrent protection, short-circuit protection, undervoltage lockout, and overtemperature.

The DRV8313 comes in a 28-pin HTSSOP PowerPAD™ package.

### ORDERING INFORMATION<sup>(1)</sup>

ORDERABLE PART NUMBER	PACKAGE <sup>(2)</sup>	TOPSIDE MARKING	SHIPPING
DRV8313PWPR	HTSSOP – PWP	DRV8313	Reel of 2000
DRV8313PWP			Tube of 50

- (1) For the most-current packaging and ordering information, see the Package Option Addendum at the end of this document, or see the TI Web site at [www.ti.com](http://www.ti.com).
- (2) See package drawings, thermal data, and symbolization at [www.ti.com/packaging](http://www.ti.com/packaging).



Please be aware that an important notice concerning availability, standard warranty, and use in critical applications of Texas Instruments semiconductor products and disclaimers thereto appears at the end of this data sheet.

PowerPAD is a trademark of Texas Instruments.

All other trademarks are the property of their respective owners.



This integrated circuit can be damaged by ESD. Texas Instruments recommends that all integrated circuits be handled with appropriate precautions. Failure to observe proper handling and installation procedures can cause damage.

ESD damage can range from subtle performance degradation to complete device failure. Precision integrated circuits may be more susceptible to damage because very small parametric changes could cause the device not to meet its published specifications.

### FUNCTIONAL BLOCK DIAGRAM

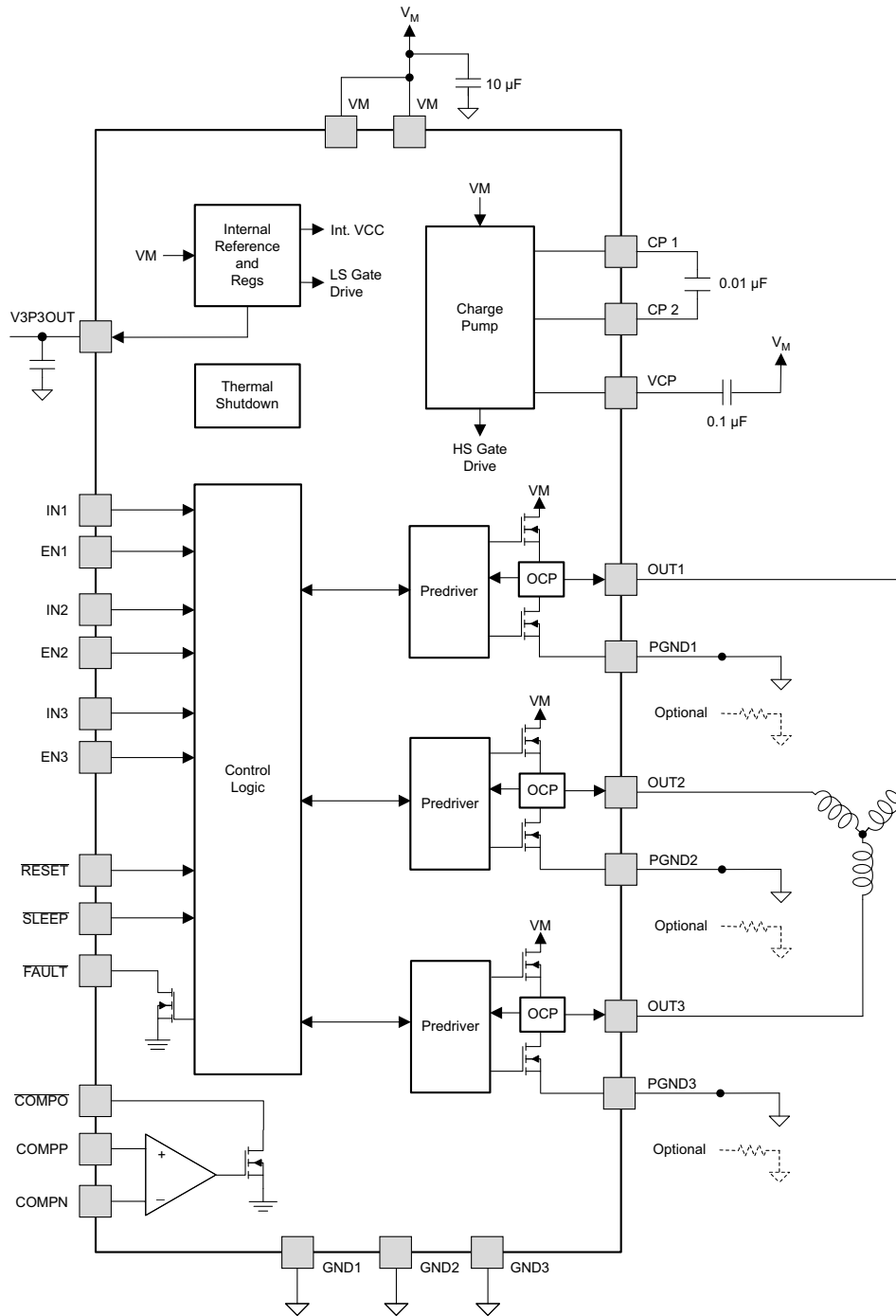

B0480-01

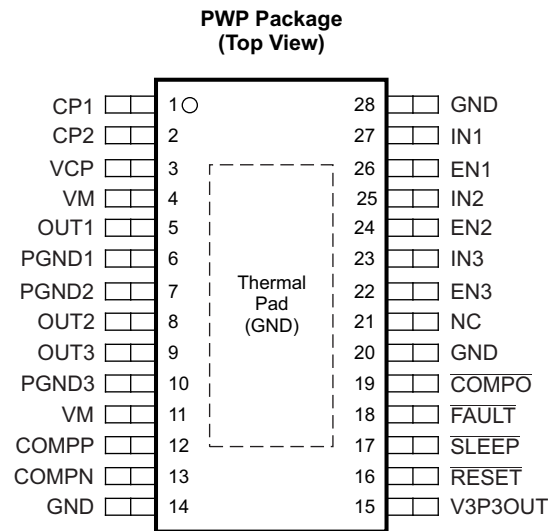

P0146-01

### PIN DESCRIPTIONS

PIN		TYPE	DESCRIPTION	EXTERNAL COMPONENTS OR CONNECTIONS
NAME	NO.			
<b>Power and Ground</b>				
CP1	1	IO	Charge-pump flying capacitor	Connect a 0.01- $\mu$ F 100-V capacitor between CP1 and CP2.
CP2	2	IO	Charge-pump flying capacitor	
GND	12, 20, 28, PPAD	–	Device ground	Connect to system ground
V3P3OUT	15	O	3.3-V regulator output	Bypass to GND with a 0.47- $\mu$ F 6.3-V ceramic capacitor. Use for supplying external loads is permissible.
VCP	3	IO	High-side gate drive voltage	Connect a 0.1- $\mu$ F 16-V ceramic capacitor to VM.
VM	4, 11	–	Main power supply	Connect to power supply (8.2 V–60 V). Connect both pins to the same supply. Bypass to GND with a 10- $\mu$ F (minimum) capacitor.
<b>Control</b>				
EN1	26	I	Channel 1 enable	Logic high enables OUT1. Internal pulldown
EN2	24	I	Channel 2 enable	Logic high enables OUT2. Internal pulldown
EN3	22	I	Channel 3 enable	Logic high enables OUT3. Internal pulldown
IN1	27	I	Channel 1 input	Logic input controls state of OUT1. Internal pulldown
IN2	25	I	Channel 2 input	Logic input controls state of OUT2. Internal pulldown
IN3	23	I	Channel 3 input	Logic input controls state of OUT3. Internal pulldown
nRESET	16	I	Reset input	Active-low reset input initializes internal logic and disables the outputs. Internal pulldown
nSLEEP	17	I	Sleep-mode input	Logic high to enable device, logic low to enter low-power sleep mode. Internal pulldown
<b>Status</b>				
nFAULT	18	OD	Fault	Logic low when in fault condition (overtemperature, overcurrent, UVLO)
<b>Comparator</b>				
COMPN	13	I	Comparator negative input	Negative input of comparator
COMPP	12	I	Comparator positive input	Positive input of comparator
nCOMPO	19	OD	Comparator out	Output of comparator. Open-drain output

**PIN DESCRIPTIONS (continued)**

PIN		TYPE	DESCRIPTION	EXTERNAL COMPONENTS OR CONNECTIONS
NAME	NO.			
<b>Output</b>				
OUT1	5	O	Output 1	Connect to loads.
OUT2	8	O	Output 2	
OUT3	9	O	Output 3	
PGND1	6	–	Ground for OUT1	Connect to ground, or to low-side current-sense resistors.
PGND2	7	–	Ground for OUT2	
PGND3	10	–	Ground for OUT3	

**ABSOLUTE MAXIMUM RATINGS**

over operating free-air temperature range (unless otherwise noted)<sup>(1)(2)</sup>

	VALUE	UNIT
Power-supply voltage range ( $V_M$ )	–0.3 V to 65	V
Digital-pin voltage range	–0.5 to 7	V
Comparator input-voltage range	–0.5 to 7	V
Peak motor-drive output current	Internally limited	A
Pin voltage (GND1, GND2, GND3)	±600	mV
Continuous motor-drive output current <sup>(3)</sup>	2.5	A
$T_J$ Operating virtual junction temperature range	–40 to 150	°C
$T_{stg}$ Storage temperature range	–60 to 150	°C

- (1) Stresses beyond those listed under *Absolute Maximum Ratings* may cause permanent damage to the device. These are stress ratings only, and functional operation of the device at these or any other conditions beyond those indicated under *Recommended Operating Conditions* is not implied. Exposure to absolute-maximum-rated conditions for extended periods may affect device reliability.
- (2) All voltage values are with respect to the network ground terminal.
- (3) Observe power dissipation and thermal limits.

**THERMAL INFORMATION**

THERMAL METRIC <sup>(1)</sup>		DRV8313	UNIT
		PWP	
		28 PINS	
$\theta_{JA}$	Junction-to-ambient thermal resistance <sup>(2)</sup>	31.6	°C/W
$\theta_{JCTop}$	Junction-to-case (top) thermal resistance <sup>(3)</sup>	15.9	°C/W
$\theta_{JB}$	Junction-to-board thermal resistance <sup>(4)</sup>	5.6	°C/W
$\psi_{JT}$	Junction-to-top characterization parameter <sup>(5)</sup>	0.2	°C/W
$\psi_{JB}$	Junction-to-board characterization parameter <sup>(6)</sup>	5.5	°C/W
$\theta_{JCbott}$	Junction-to-case (bottom) thermal resistance <sup>(7)</sup>	1.4	°C/W

- (1) For more information about traditional and new thermal metrics, see the *IC Package Thermal Metrics* application report, [SPRA953](#).
- (2) The junction-to-ambient thermal resistance under natural convection is obtained in a simulation on a JEDEC-standard, high-K board, as specified in JESD51-7, in an environment described in JESD51-2a.
- (3) The junction-to-case (top) thermal resistance is obtained by simulating a cold plate test on the package top. No specific JEDEC-standard test exists, but a close description can be found in the ANSI SEMI standard G30-88.
- (4) The junction-to-board thermal resistance is obtained by simulating in an environment with a ring cold plate fixture to control the PCB temperature, as described in JESD51-8.
- (5) The junction-to-top characterization parameter,  $\psi_{JT}$ , estimates the junction temperature of a device in a real system and is extracted from the simulation data for obtaining  $\theta_{JA}$ , using a procedure described in JESD51-2a (sections 6 and 7).
- (6) The junction-to-board characterization parameter,  $\psi_{JB}$ , estimates the junction temperature of a device in a real system and is extracted from the simulation data for obtaining  $\theta_{JA}$ , using a procedure described in JESD51-2a (sections 6 and 7).
- (7) The junction-to-case (bottom) thermal resistance is obtained by simulating a cold plate test on the exposed (power) pad. No specific JEDEC standard test exists, but a close description can be found in the ANSI SEMI standard G30-88.

## RECOMMENDED OPERATING CONDITIONS

over operating free-air temperature range (unless otherwise noted)

		MIN	NOM	MAX	UNIT
$V_M$	Motor power-supply voltage range <sup>(1)</sup>	8		60	V
$V_{GNDX}$	GND1, GND2, GND3 pin voltage	-500	0	500	mV
$I_{V3P3}$	V3P3OUT load current	0		10	mA

 (1) All  $V_M$  pins must be connected to the same supply voltage.

## ELECTRICAL CHARACTERISTICS

 $T_A = 25^\circ\text{C}$ , over operating free-air temperature range (unless otherwise noted)

PARAMETER	TEST CONDITIONS	MIN	TYP	MAX	UNIT		
<b>Power Supplies</b>							
$I_{VM}$	VM operating supply current	$V_M = 24\text{ V}$ , $f_{PWM} < 50\text{ kHz}$		1	5	mA	
$I_{VMQ}$	VM sleep-mode supply current	$V_M = 24\text{ V}$		500	800	$\mu\text{A}$	
$V_{UVLO}$	VM undervoltage lockout voltage	$V_M$ rising		6.3	8	V	
<b>V3P3OUT Regulator</b>							
$V_{3P3}$	V3P3OUT voltage	$I_{OUT} = 0$ to 10 mA		3.1	3.3	3.52	V
<b>Logic-Level Inputs</b>							
$V_{IL}$	Input low voltage			0.6	0.7	V	
$V_{IH}$	Input high voltage			2.2	5.25	V	
$V_{HYS}$	Input hysteresis			50	600	mV	
$I_{IL}$	Input low current	$V_{IN} = 0$		-5	5	$\mu\text{A}$	
$I_{IH}$	Input high current	$V_{IN} = 3.3\text{ V}$			100	$\mu\text{A}$	
$R_{PD}$	Pulldown resistance			100		k $\Omega$	
<b>nFAULT and COMPO OutputS (Open-Drain Outputs)</b>							
$V_{OL}$	Output low voltage	$I_O = 5\text{ mA}$			0.5	V	
$I_{OH}$	Output high leakage current	$V_O = 3.3\text{ V}$			1	$\mu\text{A}$	
<b>Comparator</b>							
$V_{CM}$	Common-mode input-voltage range			0	5	V	
$V_{IO}$	Input offset voltage			-7	7	mV	
$I_{IB}$	Input bias current			-300	300	nA	
$t_R$	Response time	100-mV step with 10-mV overdrive			2	$\mu\text{s}$	
<b>H-Bridge FETs</b>							
$r_{ds(on)}$	High-side FET on-resistance	$V_M = 24\text{ V}$ , $I_O = 1\text{ A}$ , $T_J = 25^\circ\text{C}$		0.24		$\Omega$	
		$V_M = 24\text{ V}$ , $I_O = 1\text{ A}$ , $T_J = 85^\circ\text{C}$		0.29	0.39		
$r_{ds(on)}$	Low-side FET on-resistance	$V_M = 24\text{ V}$ , $I_O = 1\text{ A}$ , $T_J = 25^\circ\text{C}$		0.24		$\Omega$	
		$V_M = 24\text{ V}$ , $I_O = 1\text{ A}$ , $T_J = 85^\circ\text{C}$		0.29	0.39		
$I_{OFF}$	Off-state leakage current			-2	2	$\mu\text{A}$	
$t_{DEAD}$	Output dead time			90		ns	
<b>Protection Circuits</b>							
$I_{OCP}$	Overcurrent protection trip level			3		A	
$t_{OCP}$	Overcurrent protection deglitch time			5		$\mu\text{s}$	
$T_{TSD}$	Thermal shutdown temperature	Die temperature		150	160	180	$^\circ\text{C}$

### SWITCHING CHARACTERISTICS<sup>(1)</sup>

$T_A = 25^\circ$ ,  $V_M = 24$  V,  $R_L = 20 \Omega$

NO.	PARAMETER	DESCRIPTION	MIN	MAX	UNIT
1	$t_1$	Delay time, ENx high to OUTx high, INx = 1	130	330	ns
2	$t_2$	Delay time, ENx low to OUTx low, INx = 1	275	475	ns
3	$t_3$	Delay time, ENx high to OUTx low, INx = 0	100	300	ns
4	$t_4$	Delay time, ENx low to OUTx high, INx = 0	200	400	ns
5	$t_5$	Delay time, INx high to OUTx high	300	500	ns
6	$t_6$	Delay time, INx low to OUTx low	275	475	ns
7	$t_r$	Output rise time, resistive load to GND	30	150	ns
8	$t_f$	Output fall time, resistive load to GND	30	150	ns

(1) Not production tested

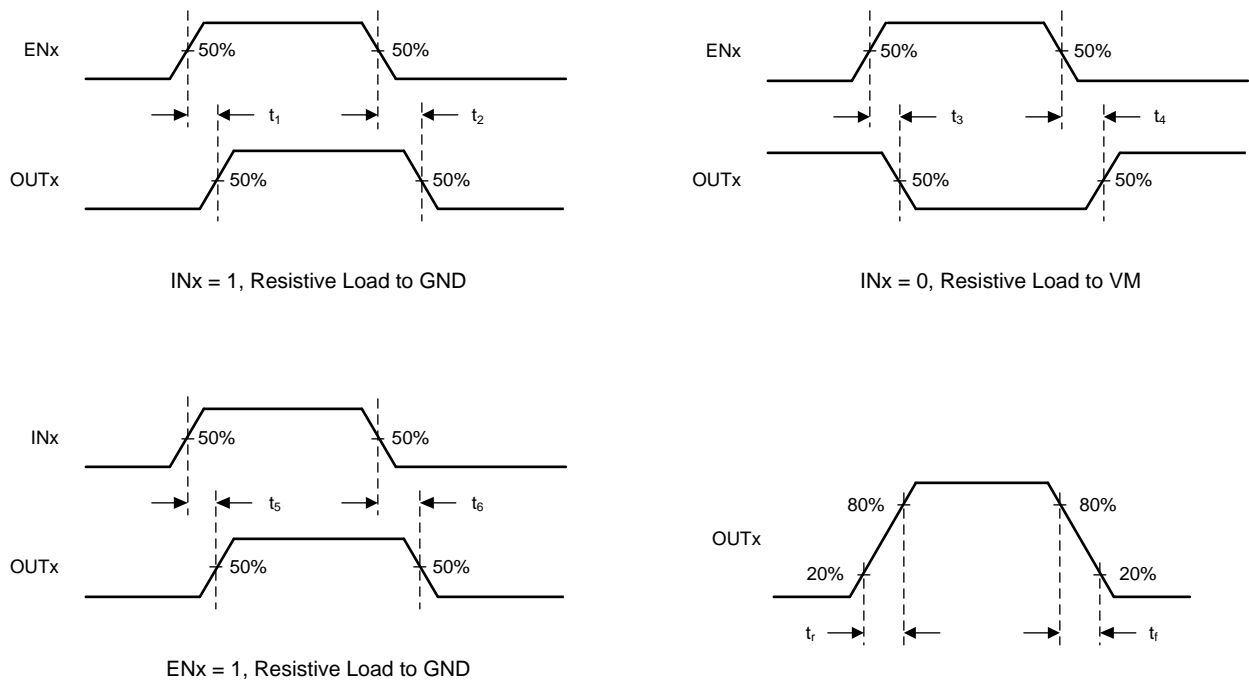

T0543-01

Figure 1. DRV8313 Switching Characteristics

## FUNCTIONAL DESCRIPTION

### Output Stage

The DRV8313 contains three half-H-bridge drivers. The source terminals of the low-side FETs of all three half-H-bridges terminate at separate pins (GND1, GND2, and GND3) to allow the use of a low-side current-sense resistor on each output, if desired. The user may also connect all three together to a single low-side sense resistor, or may connect them directly to ground if there is no need for current sensing.

If using a low-side sense resistor, take care to ensure that the voltage on the GND1, GND2, or GND3 pin does not exceed  $\pm 500$  mV.

Note that there are multiple VM motor power-supply pins. Connect all VM pins together to the motor-supply voltage.

### Bridge Control

The INx input pins directly control the state (high or low) of the OUTx outputs; the ENx input pins enable or disable the OUTx driver. The following table shows the logic:

INx	ENx	OUTx
X	0	Z
0	1	L
1	1	H

### Charge Pump

Because the output stages use N-channel FETs, the device requires a gate-drive voltage higher than the VM power supply to enhance the high-side FETs fully. The DRV8313 integrates a charge-pump circuit that generates a voltage above the VM supply for this purpose.

The charge pump requires two external capacitors for operation. See the block diagram and pin descriptions for details on these capacitors (value, connection, and so forth).

The charge pump shuts down when nSLEEP is active-low.

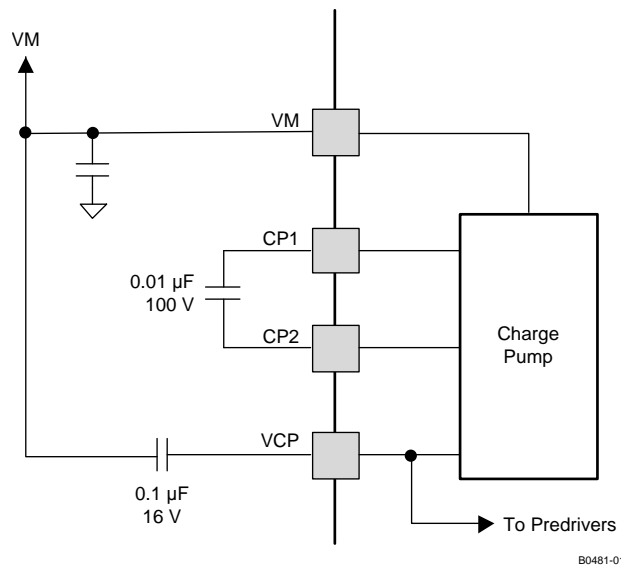
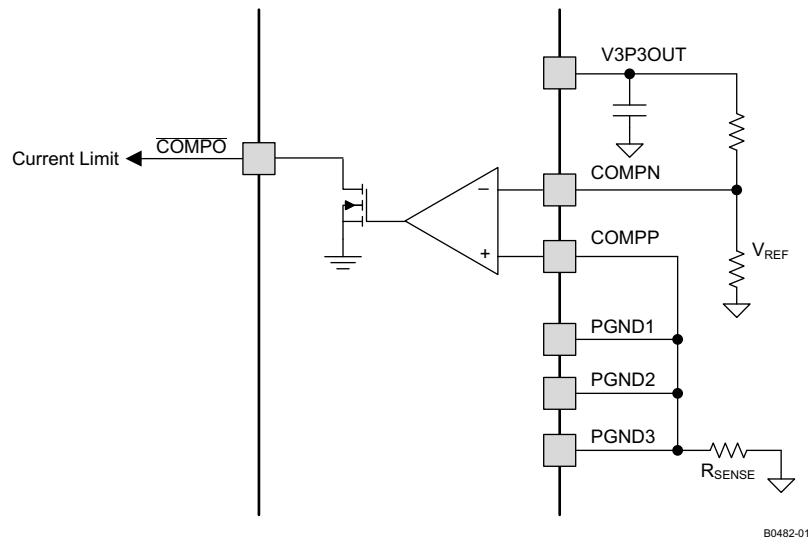

Figure 2. DRV8313 Charge Pump

## Comparator

The DRV8313 includes an uncommitted comparator, which can find use as a current-limit comparator or for other purposes.

The following diagram shows connections to use the comparator to sense current for implementing a current limit. Current from all three low-side FETs is sensed using a single low-side sense resistor. The voltage across the sense resistor is compared with a reference, and when the sensed voltage exceeds the reference, a current-limit condition is signaled to the controller. The V3P3OUT internal voltage regulator can be used to set the reference voltage of the comparator.



**Figure 3. DRV8313 Comparator**

## nRESET and nSLEEP Operation

The nRESET pin, when driven active-low, resets any faults. It also disables the output drivers while it is active. The device ignores all inputs while nRESET is active. Note that there is an internal power-up-reset circuit, so that driving nRESET at power up is not required.

Driving nSLEEP low puts the device into a low-power sleep state. Entering this state disables the output drivers, stops the gate-drive charge pump, resets all internal logic (including faults), and stops all internal clocks. In this state, the device ignores all inputs until nSLEEP returns inactive-high. When returning from sleep mode, some time (approximately 1 ms) must pass before the motor driver becomes fully operational. Note that the V3P3 regulator remains operational in sleep mode.

## Protection Circuits

The DRV8313 has full protection against undervoltage, overcurrent, and overtemperature events.

### OVERCURRENT PROTECTION (OCP)

An analog current-limit circuit on each FET limits the current through the FET by removing the gate drive. If this analog current limit persists for longer than the OCP deglitch time, the device disables the channel experiencing the overcurrent and drives the nFAULT pin low. The driver remains off until either assertion of nRESET or the cycling of VM power.

Overcurrent conditions on both high- and low-side devices, that is, a short to ground, supply, or across the motor winding, all result in an overcurrent shutdown.

### THERMAL SHUTDOWN (TSD)

If the die temperature exceeds safe limits, the device disables all outputs and drives the nFAULT pin low. Once the die temperature has fallen to a safe level, operation automatically resumes.

## UNDERVOLTAGE LOCKOUT (UVLO)

If at any time the voltage on the VM pins falls below the undervoltage-lockout threshold voltage, the device disables all outputs, resets internal logic, and drives the nFAULT pin low. Operation resumes when VM rises above the UVLO threshold.

## THERMAL INFORMATION

### Thermal Protection

The DRV8313 has thermal shutdown (TSD) as previously described. A die temperature in excess of approximately 150°C disables the device until the temperature drops to a safe level.

Any tendency of the device to enter thermal shutdown is an indication of excessive power dissipation, insufficient heatsinking, or too high an ambient temperature.

### Power Dissipation

The power dissipated in the output FET resistance, or  $r_{DS(on)}$  dominates power dissipation in the DRV8313. A rough estimate of average power dissipation of each half-H-bridge when running a static load is:

$$P = r_{DS(on)} \times (I_{OUT})^2 \quad (1)$$

where P is the power dissipation of one H-bridge,  $r_{DS(on)}$  is the resistance of each FET, and  $I_{OUT}$  is equal to the average current drawn by the load. Note that at start-up and fault conditions, this current is much higher than normal running current; remember to take these peak currents and their duration into consideration.

The total device dissipation is the power dissipated in each of the three half-H-bridges added together.

The maximum amount of power that the device can dissipate depends on ambient temperature and heatsinking.

Note that  $r_{DS(on)}$  increases with temperature, so as the device heats, the power dissipation increases. Take this into consideration when sizing the heatsink.

### Heatsinking

The PowerPAD package uses an exposed pad to remove heat from the device. For proper operation, this pad must be thermally connected to copper on the PCB to dissipate heat. On a multi-layer PCB with a ground plane, add a number of vias to connect the thermal pad to the ground plane to accomplish this. On PCBs without internal planes, add copper area on either side of the PCB to dissipate heat. If the copper area is on the opposite side of the PCB from the device, use thermal vias to transfer the heat between the top and bottom layers.

For details about how to design the PCB, see TI Application Report [SLMA002](#), *PowerPAD Thermally Enhanced Package* and TI Application Brief [SLMA004](#), *PowerPAD Made Easy*, available at [www.ti.com](http://www.ti.com).

In general, providing more copper area allows the dissipation of more power.

## APPLICATION INFORMATION

### Output Configurations and Connections

The typical application for the DRV8313 is to drive a 3-phase brushless motor. In this application, the three outputs connect to the three motor leads, as shown in Figure 4.

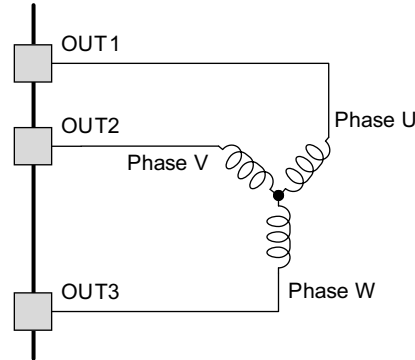

Figure 4. Three-Phase Motor Connection

The device achieves standard 120° (also called trapezoidal or block) commutation, using synchronous rectification, by following the states shown in Table 1

Table 1. Three-Phase Motor Signals

State	OUT1 (Phase U)			OUT2 (Phase V)			OUT3 (Phase W)		
	IN1	EN1	OUT1	IN2	EN2	OUT2	IN3	EN3	OUT3
1	X	0	Z	1 / PWM	1	H / PWM	0	1	L
2	1 / PWM	1	H / PWM	X	0	Z	0	1	L
3	1 / PWM	1	H / PWM	0	1	L	X	0	Z
4	X	0	Z	0	1	L	1 / PWM	1	H / PWM
5	0	1	L	X	0	Z	1 / PWM	1	H / PWM
6	0	1	L	1 / PWM	1	H / PWM	X	0	Z

One can implement asynchronous rectification by also applying the PWM signal to the enable inputs.

The DRV8313 can drive other loads, including dc brush motors and solenoids. For example, one could drive a dc brush motor in both directions, plus a single solenoid or unidirectional dc brush motor:

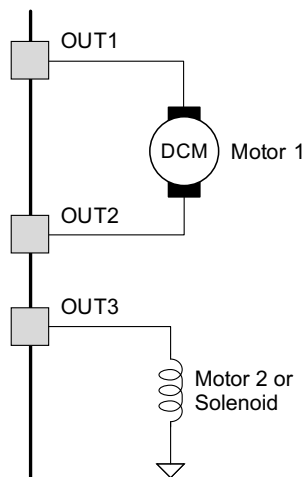

Figure 5. Bidirectional Motor Plus Motor or Solenoid Connection

The functions would be as shown in [Table 2](#).

**Table 2. Bidirectional Motor Plus Motor or Solenoid Signals**

Motor 1							Motor 2 or Solenoid			
Function	IN1	EN1	OUT1	IN2	EN2	OUT2	Function	IN3	EN3	OUT3
Off or coast	X	0	Z	X	X	X	On	1 / PWM	1	1
Off or coast	X	X	X	X	0	X	Off or slow decay	0	1	0
Forward	1 / PWM	1	1	0	1	0	Off or coast	X	0	X
Reverse	0	1	0	1 / PWM	1	1				
Brake or slow decay	0	1	0	0	1	0				
Brake or slow decay	1	1	1	1	1	1				

Applying a PWM signal to the appropriate INx pin(s) as shown in [Table 2](#) could implement PWM speed control. Another possibility is controlling three different loads. Note that it is possible to return one side of the load either to the power supply (VM) or to ground.

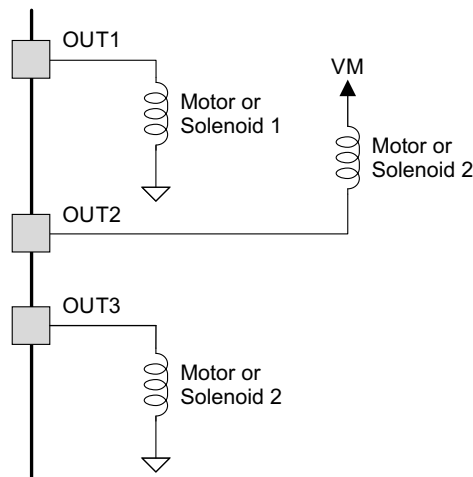

**Figure 6. Three Independent Load Connections**

**Table 3. Three Independent Load Signals**

Motor or Solenoid 1			Motor or Solenoid 2				Motor or Solenoid 3				
Function	IN1	EN1	OUT1	Function	IN2	EN2	OUT2	Function	IN3	EN3	OUT3
On	1 / PWM	1	1	On	1 / PWM	1	1	On	1 / PWM	1	1
Off or slow decay	0	1	0	Off or slow decay	0	1	0	Off or slow decay	0	1	0
Off or coast	X	0	X	Off or coast	X	0	X	Off or coast	X	0	X

**PACKAGING INFORMATION**

Orderable Device	Status (1)	Package Type	Package Drawing	Pins	Package Qty	Eco Plan (2)	Lead/Ball Finish	MSL Peak Temp (3)	Samples (Requires Login)
DRV8313PWP	ACTIVE	HTSSOP	PWP	28	50	Green (RoHS & no Sb/Br)	CU NIPDAU	Level-3-260C-168 HR	
DRV8313PWPR	ACTIVE	HTSSOP	PWP	28	2000	Green (RoHS & no Sb/Br)	CU NIPDAU	Level-3-260C-168 HR	

(1) The marketing status values are defined as follows:

**ACTIVE:** Product device recommended for new designs.

**LIFEBUY:** TI has announced that the device will be discontinued, and a lifetime-buy period is in effect.

**NRND:** Not recommended for new designs. Device is in production to support existing customers, but TI does not recommend using this part in a new design.

**PREVIEW:** Device has been announced but is not in production. Samples may or may not be available.

**OBSELETE:** TI has discontinued the production of the device.

(2) Eco Plan - The planned eco-friendly classification: Pb-Free (RoHS), Pb-Free (RoHS Exempt), or Green (RoHS & no Sb/Br) - please check <http://www.ti.com/productcontent> for the latest availability information and additional product content details.

**TBD:** The Pb-Free/Green conversion plan has not been defined.

**Pb-Free (RoHS):** TI's terms "Lead-Free" or "Pb-Free" mean semiconductor products that are compatible with the current RoHS requirements for all 6 substances, including the requirement that lead not exceed 0.1% by weight in homogeneous materials. Where designed to be soldered at high temperatures, TI Pb-Free products are suitable for use in specified lead-free processes.

**Pb-Free (RoHS Exempt):** This component has a RoHS exemption for either 1) lead-based flip-chip solder bumps used between the die and package, or 2) lead-based die adhesive used between the die and leadframe. The component is otherwise considered Pb-Free (RoHS compatible) as defined above.

**Green (RoHS & no Sb/Br):** TI defines "Green" to mean Pb-Free (RoHS compatible), and free of Bromine (Br) and Antimony (Sb) based flame retardants (Br or Sb do not exceed 0.1% by weight in homogeneous material)

(3) MSL, Peak Temp. -- The Moisture Sensitivity Level rating according to the JEDEC industry standard classifications, and peak solder temperature.

**Important Information and Disclaimer:** The information provided on this page represents TI's knowledge and belief as of the date that it is provided. TI bases its knowledge and belief on information provided by third parties, and makes no representation or warranty as to the accuracy of such information. Efforts are underway to better integrate information from third parties. TI has taken and continues to take reasonable steps to provide representative and accurate information but may not have conducted destructive testing or chemical analysis on incoming materials and chemicals. TI and TI suppliers consider certain information to be proprietary, and thus CAS numbers and other limited information may not be available for release.

In no event shall TI's liability arising out of such information exceed the total purchase price of the TI part(s) at issue in this document sold by TI to Customer on an annual basis.

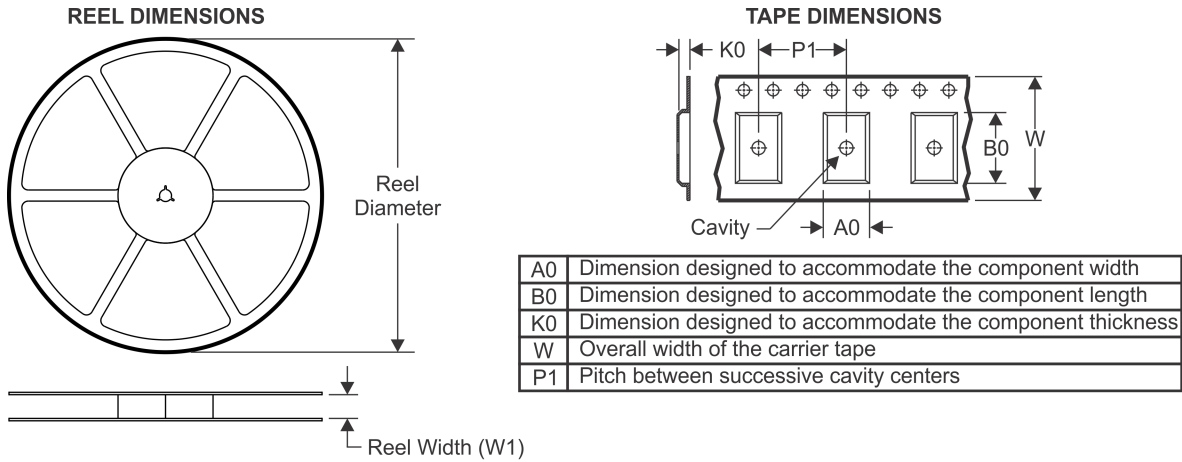
**TAPE AND REEL INFORMATION**

**QUADRANT ASSIGNMENTS FOR PIN 1 ORIENTATION IN TAPE**

\*All dimensions are nominal

Device	Package Type	Package Drawing	Pins	SPQ	Reel Diameter (mm)	Reel Width W1 (mm)	A0 (mm)	B0 (mm)	K0 (mm)	P1 (mm)	W (mm)	Pin1 Quadrant
DRV8313PWPR	HTSSOP	PWP	28	2000	330.0	16.4	6.9	10.2	1.8	12.0	16.0	Q1

**TAPE AND REEL BOX DIMENSIONS**



\*All dimensions are nominal

Device	Package Type	Package Drawing	Pins	SPQ	Length (mm)	Width (mm)	Height (mm)
DRV8313PWPR	HTSSOP	PWP	28	2000	367.0	367.0	38.0

# MECHANICAL DATA

PWP (R-PDSO-G28)

PowerPAD™ PLASTIC SMALL OUTLINE

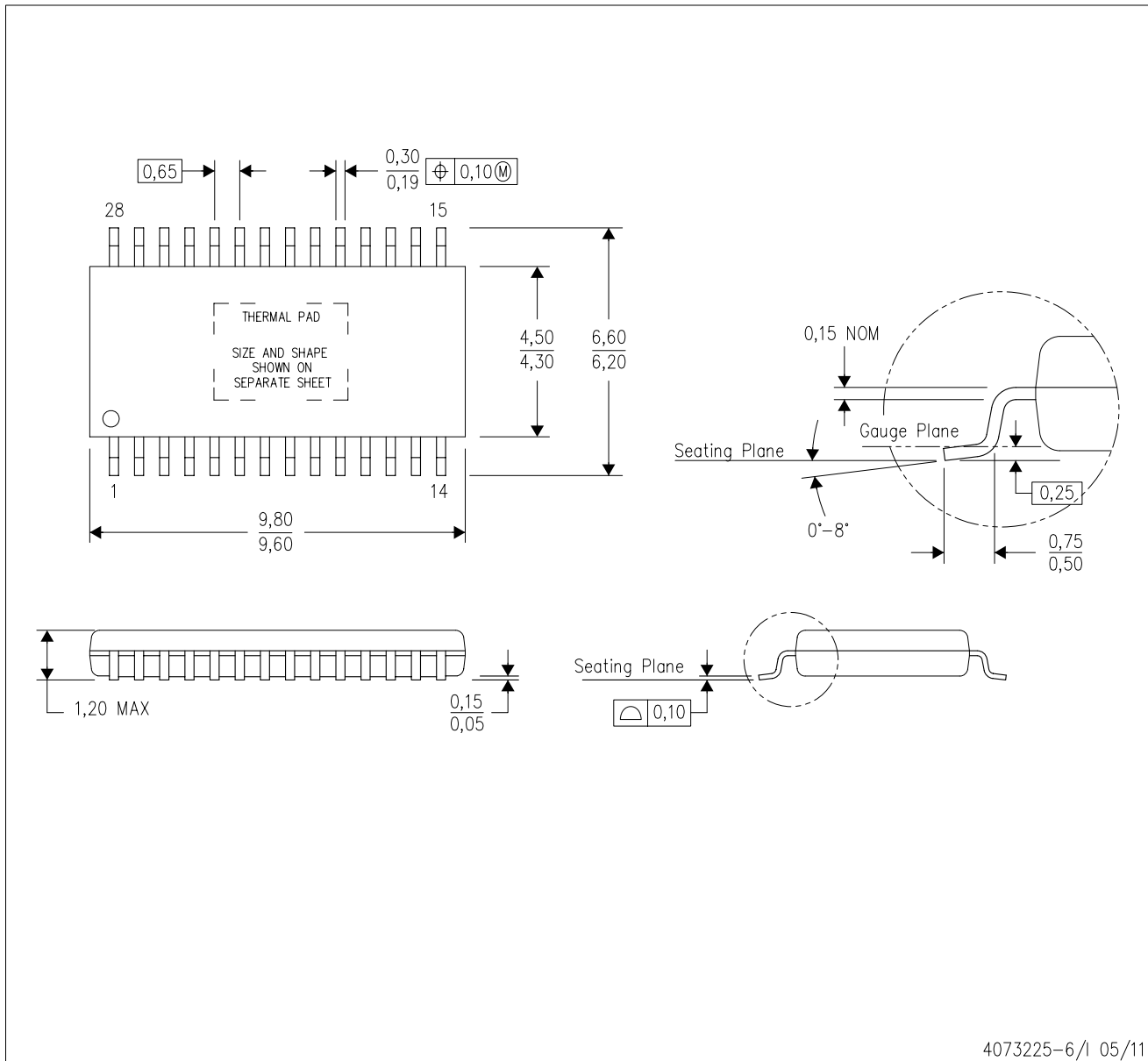

- NOTES:
- All linear dimensions are in millimeters.
  - This drawing is subject to change without notice.
  - Body dimensions do not include mold flash or protrusions. Mold flash and protrusion shall not exceed 0.15 per side.
  - This package is designed to be soldered to a thermal pad on the board. Refer to Technical Brief, PowerPad Thermally Enhanced Package, Texas Instruments Literature No. SLMA002 for information regarding recommended board layout. This document is available at [www.ti.com](http://www.ti.com) <<http://www.ti.com>>.
  - See the additional figure in the Product Data Sheet for details regarding the exposed thermal pad features and dimensions.
  - Falls within JEDEC MO-153

PowerPAD is a trademark of Texas Instruments.

# THERMAL PAD MECHANICAL DATA

## PWP (R-PDSO-G28) PowerPAD™ SMALL PLASTIC OUTLINE

### THERMAL INFORMATION

This PowerPAD™ package incorporates an exposed thermal pad that is designed to be attached to a printed circuit board (PCB). The thermal pad must be soldered directly to the PCB. After soldering, the PCB can be used as a heatsink. In addition, through the use of thermal vias, the thermal pad can be attached directly to the appropriate copper plane shown in the electrical schematic for the device, or alternatively, can be attached to a special heatsink structure designed into the PCB. This design optimizes the heat transfer from the integrated circuit (IC).

For additional information on the PowerPAD package and how to take advantage of its heat dissipating abilities, refer to Technical Brief, PowerPAD Thermally Enhanced Package, Texas Instruments Literature No. SLMA002 and Application Brief, PowerPAD Made Easy, Texas Instruments Literature No. SLMA004. Both documents are available at [www.ti.com](http://www.ti.com).

The exposed thermal pad dimensions for this package are shown in the following illustration.

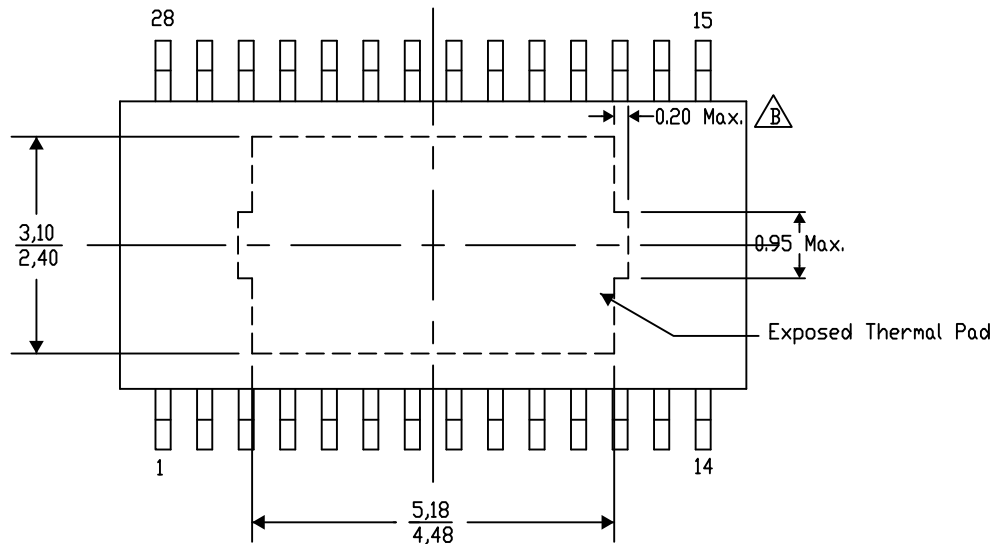

Exposed Thermal Pad Dimensions

4206332-38/AC 07/12

NOTE: A. All linear dimensions are in millimeters  
B. Exposed tie strap features may not be present.

PowerPAD is a trademark of Texas Instruments

PWP (R-PDSO-G28)

PowerPAD™ PLASTIC SMALL OUTLINE

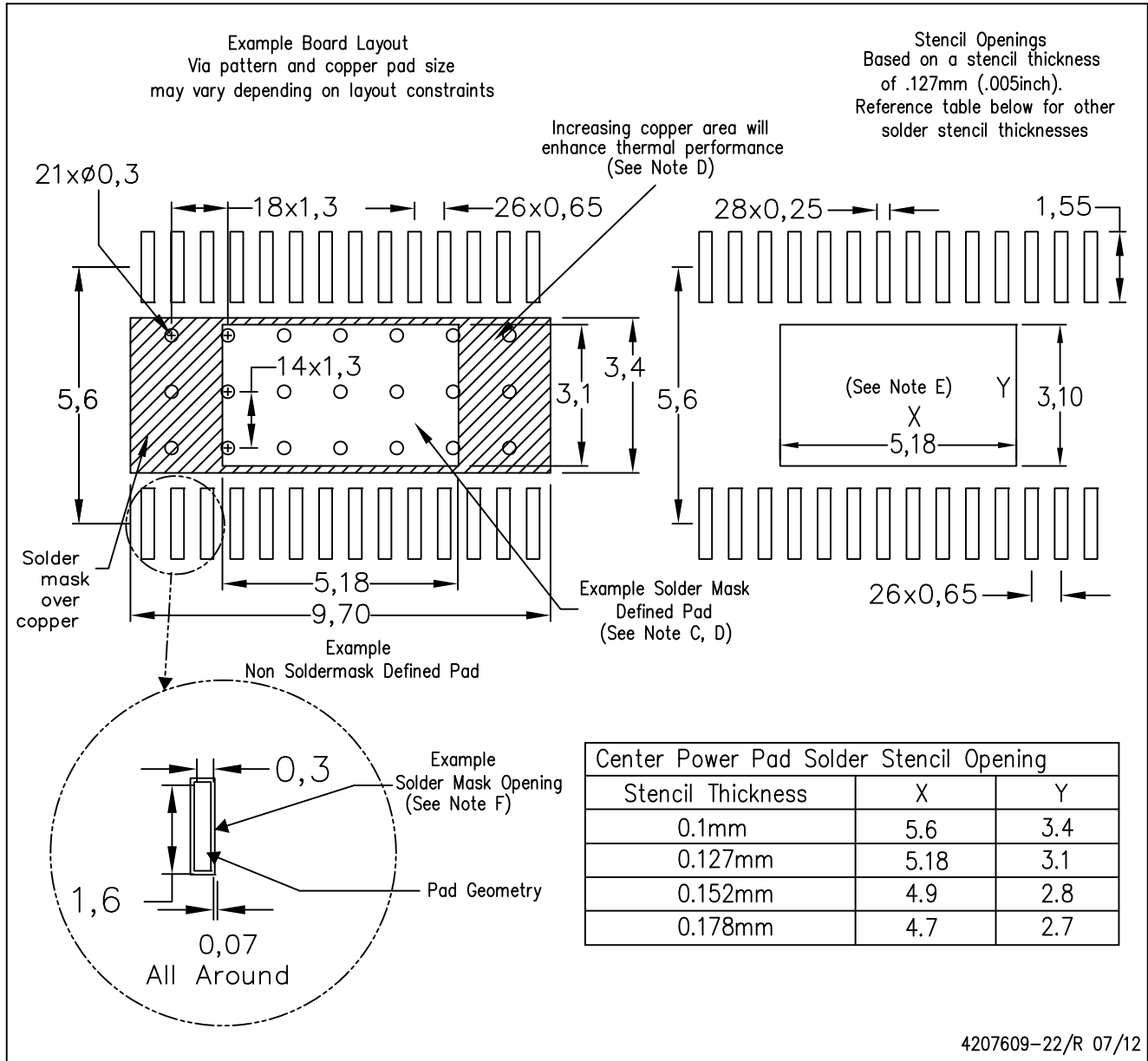

- NOTES:
- All linear dimensions are in millimeters.
  - This drawing is subject to change without notice.
  - Customers should place a note on the circuit board fabrication drawing not to alter the center solder mask defined pad.
  - This package is designed to be soldered to a thermal pad on the board. Refer to Technical Brief, PowerPad Thermally Enhanced Package, Texas Instruments Literature No. SLMA002, SLMA004, and also the Product Data Sheets.
  - For specific thermal information, via requirements, and recommended board layout. These documents are available at [www.ti.com](http://www.ti.com) <<http://www.ti.com>>. Publication IPC-7351 is recommended for alternate designs. Laser cutting apertures with trapezoidal walls and also rounding corners will offer better paste release. Customers should contact their board assembly site for stencil design recommendations. Example stencil design based on a 50% volumetric metal load solder paste. Refer to IPC-7525 for other stencil
  - Customers should contact their board fabrication site for solder mask tolerances between and around signal pads.

## IMPORTANT NOTICE

Texas Instruments Incorporated and its subsidiaries (TI) reserve the right to make corrections, enhancements, improvements and other changes to its semiconductor products and services per JESD46, latest issue, and to discontinue any product or service per JESD48, latest issue. Buyers should obtain the latest relevant information before placing orders and should verify that such information is current and complete. All semiconductor products (also referred to herein as "components") are sold subject to TI's terms and conditions of sale supplied at the time of order acknowledgment.

TI warrants performance of its components to the specifications applicable at the time of sale, in accordance with the warranty in TI's terms and conditions of sale of semiconductor products. Testing and other quality control techniques are used to the extent TI deems necessary to support this warranty. Except where mandated by applicable law, testing of all parameters of each component is not necessarily performed.

TI assumes no liability for applications assistance or the design of Buyers' products. Buyers are responsible for their products and applications using TI components. To minimize the risks associated with Buyers' products and applications, Buyers should provide adequate design and operating safeguards.

TI does not warrant or represent that any license, either express or implied, is granted under any patent right, copyright, mask work right, or other intellectual property right relating to any combination, machine, or process in which TI components or services are used. Information published by TI regarding third-party products or services does not constitute a license to use such products or services or a warranty or endorsement thereof. Use of such information may require a license from a third party under the patents or other intellectual property of the third party, or a license from TI under the patents or other intellectual property of TI.

Reproduction of significant portions of TI information in TI data books or data sheets is permissible only if reproduction is without alteration and is accompanied by all associated warranties, conditions, limitations, and notices. TI is not responsible or liable for such altered documentation. Information of third parties may be subject to additional restrictions.

Resale of TI components or services with statements different from or beyond the parameters stated by TI for that component or service voids all express and any implied warranties for the associated TI component or service and is an unfair and deceptive business practice. TI is not responsible or liable for any such statements.

Buyer acknowledges and agrees that it is solely responsible for compliance with all legal, regulatory and safety-related requirements concerning its products, and any use of TI components in its applications, notwithstanding any applications-related information or support that may be provided by TI. Buyer represents and agrees that it has all the necessary expertise to create and implement safeguards which anticipate dangerous consequences of failures, monitor failures and their consequences, lessen the likelihood of failures that might cause harm and take appropriate remedial actions. Buyer will fully indemnify TI and its representatives against any damages arising out of the use of any TI components in safety-critical applications.

In some cases, TI components may be promoted specifically to facilitate safety-related applications. With such components, TI's goal is to help enable customers to design and create their own end-product solutions that meet applicable functional safety standards and requirements. Nonetheless, such components are subject to these terms.

No TI components are authorized for use in FDA Class III (or similar life-critical medical equipment) unless authorized officers of the parties have executed a special agreement specifically governing such use.

Only those TI components which TI has specifically designated as military grade or "enhanced plastic" are designed and intended for use in military/aerospace applications or environments. Buyer acknowledges and agrees that any military or aerospace use of TI components which have **not** been so designated is solely at the Buyer's risk, and that Buyer is solely responsible for compliance with all legal and regulatory requirements in connection with such use.

TI has specifically designated certain components as meeting ISO/TS16949 requirements, mainly for automotive use. In any case of use of non-designated products, TI will not be responsible for any failure to meet ISO/TS16949.

### Products

Audio	<a href="http://www.ti.com/audio">www.ti.com/audio</a>
Amplifiers	<a href="http://amplifier.ti.com">amplifier.ti.com</a>
Data Converters	<a href="http://dataconverter.ti.com">dataconverter.ti.com</a>
DLP® Products	<a href="http://www.dlp.com">www.dlp.com</a>
DSP	<a href="http://dsp.ti.com">dsp.ti.com</a>
Clocks and Timers	<a href="http://www.ti.com/clocks">www.ti.com/clocks</a>
Interface	<a href="http://interface.ti.com">interface.ti.com</a>
Logic	<a href="http://logic.ti.com">logic.ti.com</a>
Power Mgmt	<a href="http://power.ti.com">power.ti.com</a>
Microcontrollers	<a href="http://microcontroller.ti.com">microcontroller.ti.com</a>
RFID	<a href="http://www.ti-rfid.com">www.ti-rfid.com</a>
OMAP Applications Processors	<a href="http://www.ti.com/omap">www.ti.com/omap</a>
Wireless Connectivity	<a href="http://www.ti.com/wirelessconnectivity">www.ti.com/wirelessconnectivity</a>

### Applications

Automotive and Transportation	<a href="http://www.ti.com/automotive">www.ti.com/automotive</a>
Communications and Telecom	<a href="http://www.ti.com/communications">www.ti.com/communications</a>
Computers and Peripherals	<a href="http://www.ti.com/computers">www.ti.com/computers</a>
Consumer Electronics	<a href="http://www.ti.com/consumer-apps">www.ti.com/consumer-apps</a>
Energy and Lighting	<a href="http://www.ti.com/energy">www.ti.com/energy</a>
Industrial	<a href="http://www.ti.com/industrial">www.ti.com/industrial</a>
Medical	<a href="http://www.ti.com/medical">www.ti.com/medical</a>
Security	<a href="http://www.ti.com/security">www.ti.com/security</a>
Space, Avionics and Defense	<a href="http://www.ti.com/space-avionics-defense">www.ti.com/space-avionics-defense</a>
Video and Imaging	<a href="http://www.ti.com/video">www.ti.com/video</a>

### TI E2E Community

[e2e.ti.com](http://e2e.ti.com)

# Mouser Electronics

Authorized Distributor

Click to View Pricing, Inventory, Delivery & Lifecycle Information:

[Texas Instruments:](#)

[DRV8313PWPR](#) [DRV8313PWP](#)