

**1.5 - 3.5 GHz Low Power UltraCMOS®
Divide-by-8 Prescaler
Rad-hard for Space Application**

Features

- High-frequency operation
1.5 - 3.5 GHz
- Fixed divide ratio of 8
- Low-power operation
14 mA typical @ 3V across frequency
- Small package
8-lead formed flat pack
- Available as Die

Product Description

The PE9303 is a high performance monolithic UltraCMOS® prescaler with a fixed divide ratio of 8. Its operating frequency range is 1.5 GHz to 3.5 GHz. The PE9303 operates on a nominal 3V supply and draws only 14 mA. It is packaged in a small 8-lead pre-formed flat pack and is ideal for space applications.

The PE9303 is manufactured on Peregrine's UltraCMOS® process, a patented variation of silicon-on-insulator (SOI) technology on a sapphire substrate, offering the performance of GaAs with the economy and integration of conventional CMOS.

Figure 1. Functional Diagram

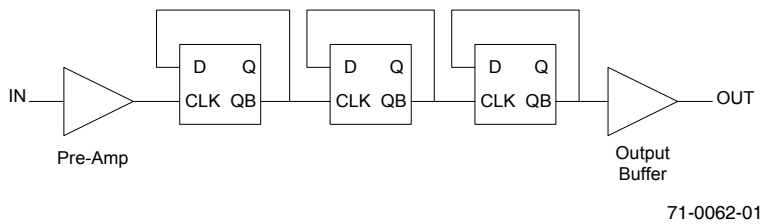
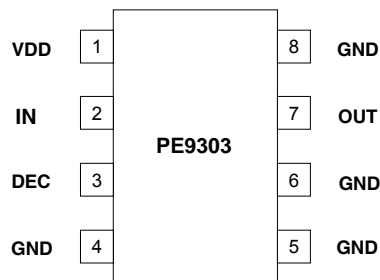

**Figure 2. Package Type
8-lead CSOIC**



Table 1. Electrical Specifications @ +25 °C ($Z_S = Z_L = 50 \Omega$)

Parameter	Minimum	Typical	Maximum	Units
Supply Voltage	2.85	3.0	3.15	V
Supply Current		14	17	mA
Input Frequency (FIN)	1.5		3.5	GHz
Input Power (PIN)	-10		+5	dBm
Output Power	-5			dBm

Figure 3. Pin Configuration

Table 2. Pin Descriptions

Pin No.	Pin Name	Description
1	VDD	Power supply pin. Bypassing is required.
2	IN	Input signal pin. Should be coupled with a capacitor (eg 15 pF).
3	DEC	Power supply decoupling pin. Place capacitors as close as possible and connect directly to the ground plane (eg 10 nF & 10 pF).
4	GND	Ground pin. Ground pattern on the board should be as wide as possible to reduce ground impedance.
5	GND	Ground pin
6	GND	Ground pin
7	OUT	Divided frequency output pin. This pin should be coupled with a capacitor (eg 100 pF).
8	GND	Ground Pin

Table 3. Absolute Maximum Ratings

Symbol	Parameter/Conditions	Min	Max	Units
VDD	Supply voltage		4.0	V
T _{ST}	Storage temperature range	-65	150	°C
T _{OP}	Operating temperature range	-40	85	°C
VESD	ESD voltage (Human Body Model)		250	V
P _{INMAX}	Maximum input power		10	dBm

Absolute Maximum Ratings are those values listed in the above table. Exceeding these values may cause permanent device damage. Functional operation should be restricted to the limits in the DC Electrical Specifications table. Exposure to absolute maximum ratings for extended periods may affect device reliability.

Electrostatic Discharge (ESD) Precautions

When handling this UltraCMOS[®] device, observe the same precautions that you would use with other ESD-sensitive devices. Although this device contains circuitry to protect it from damage due to ESD, precautions should be taken to avoid exceeding the rating specified in *Table 3*.

Latch-Up Avoidance

Unlike conventional CMOS devices, UltraCMOS[®] devices are immune to latch-up.

Device Functional Considerations

The PE9303 takes an input signal frequency from between 1.5 GHz to 3.5 GHz and produces an output signal frequency one-fourth that of the supplied input. In order for the prescaler to work properly, several conditions need to be adhered to. It is crucial that pin 3 be supplied with a bypass capacitor to ground. In addition, the input and output signals (pins 2 and 7, respectively) need to be AC coupled via an external capacitor as shown in the test circuit below.

The ground pattern on the board should be made as wide as possible to minimize ground impedance.

Figure 4. Test Circuit Block Diagram

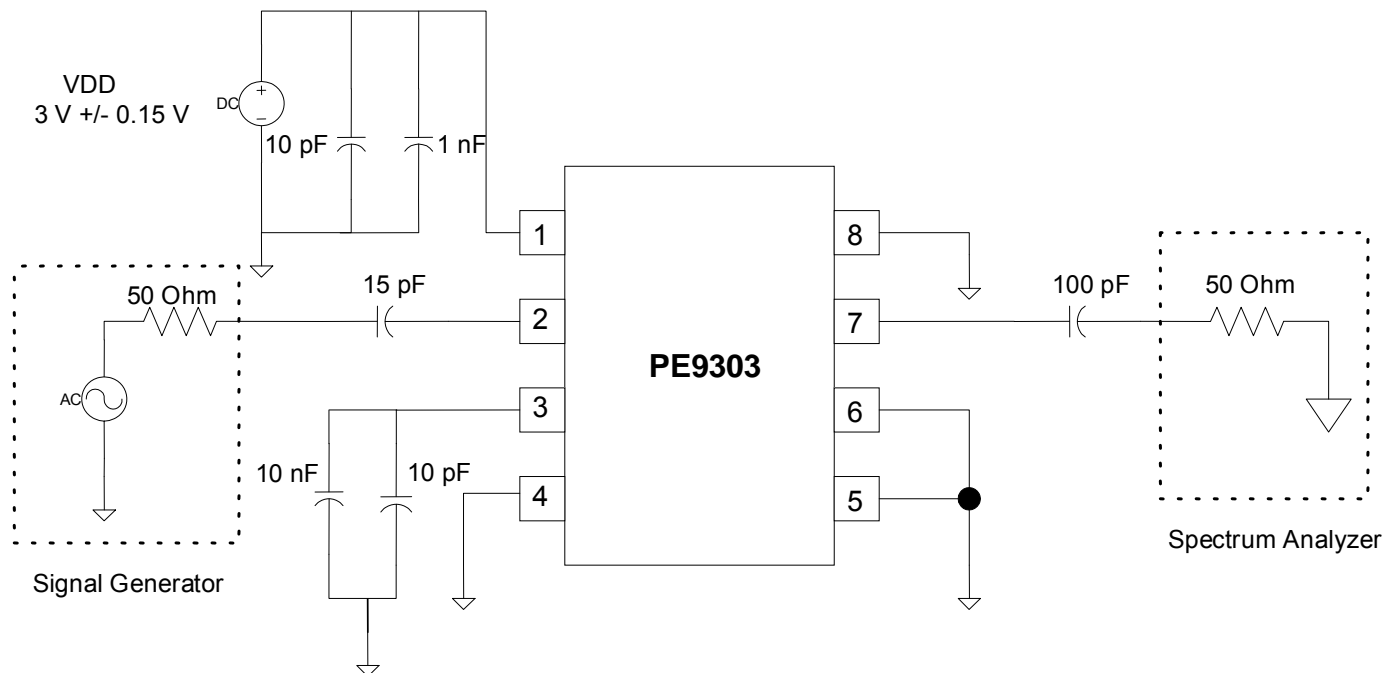
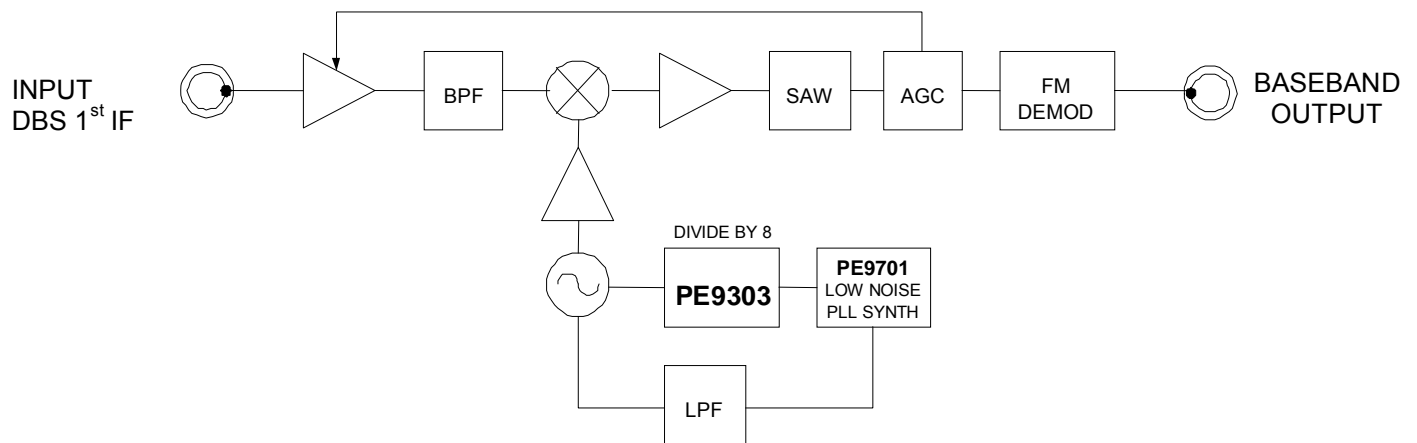

Figure 5. High Frequency System Application

The wideband frequency of operation of the PE9303 makes it an ideal part for use in a DBS down converter system.



Evaluation Kit Operation

Evaluation Board Description

The PE9303 evaluation board is depicted in *Figure 6*. The input is driven into the RF In port while the divided output is taken at Out 1. Both input and output contain footprints for AC coupling capacitors (C3 and C1 respectively). The power supply connection is provided near the top of the evaluation board, J2 Pin 1 as supply, J2 Pin 2 as ground. In addition C2, C5, and C10 are placeholders for power supply decoupling capacitors. Placeholders C4, C6, and C8 are needed for required bypass capacitors.

Note: C4 and C6 are located on the underside of the evaluation board.

Evaluation Board Test Setup

The PE9303 can be tested on the evaluation board using the test setup shown in *Figure 4*. In the test setup, it is essential that the power supply is properly decoupled and bypass capacitors are used for pin 3. In addition, the input and output need to be AC coupled.

Testing

The PE9303 Evaluation Board was measured prior to shipment using the setup depicted in *Figure 4*. Testing was performed at room temperature and $V_{DD} = 2.85V$.

Figure 6. Evaluation Board Layout

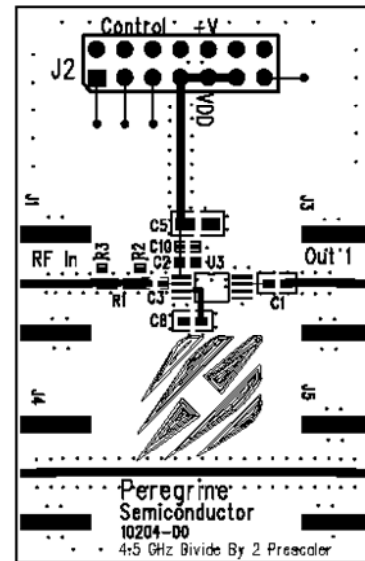

102-0034

Figure 7. Evaluation Board Schematic

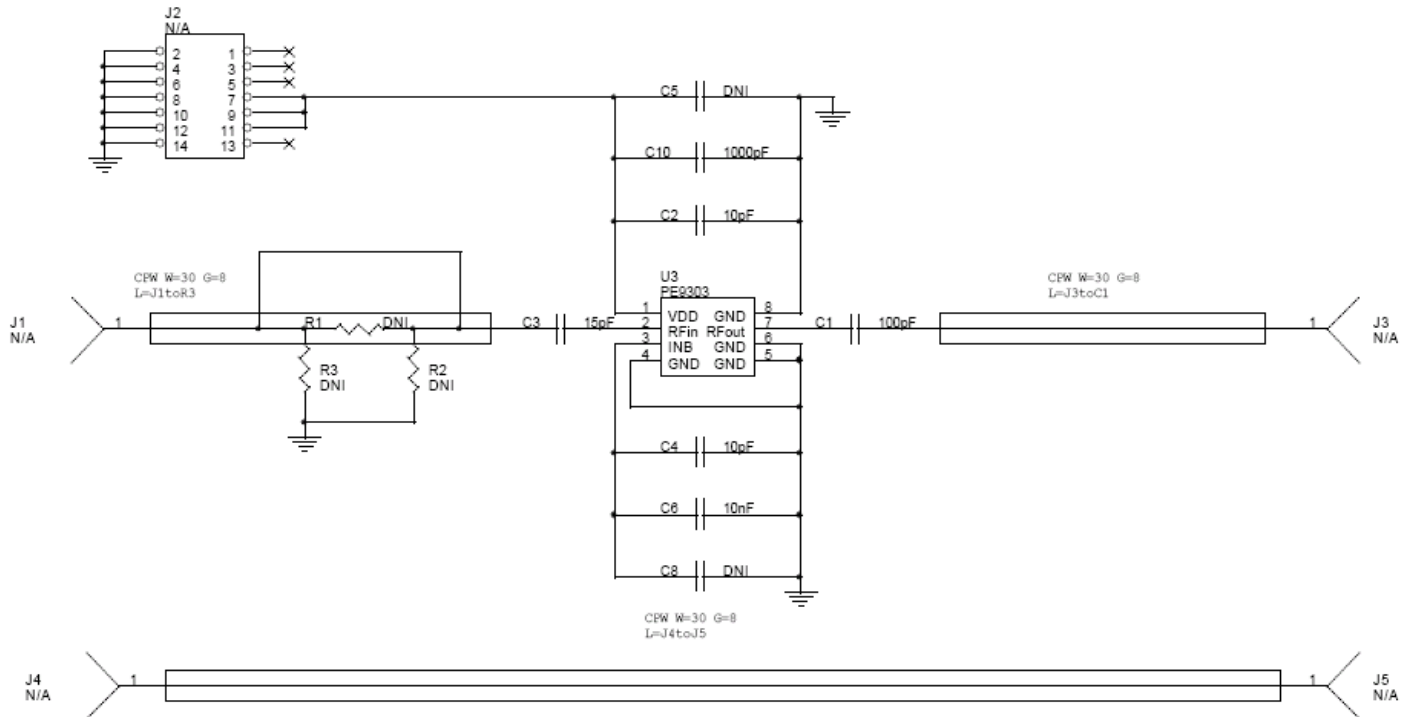

102-0074

Typical Performance Data @ +25°C

Figure 8. Typical Input Sensitivity

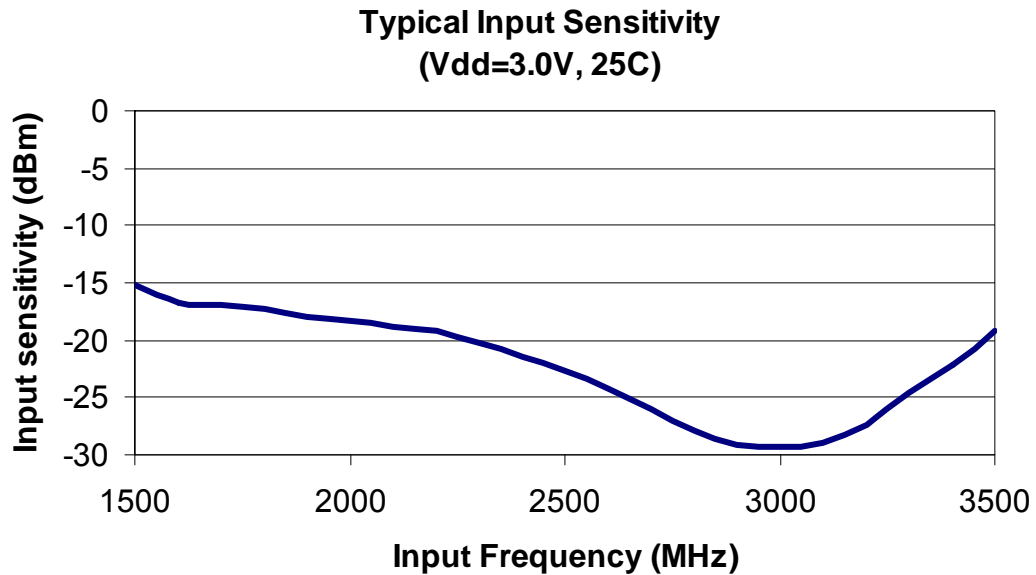

Figure 9. Typical Output Power

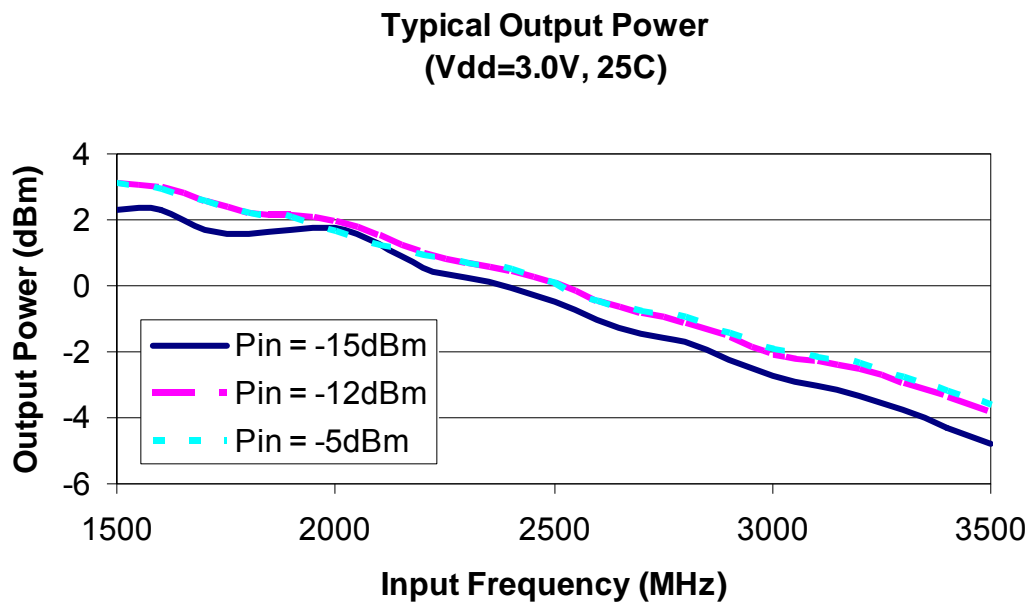
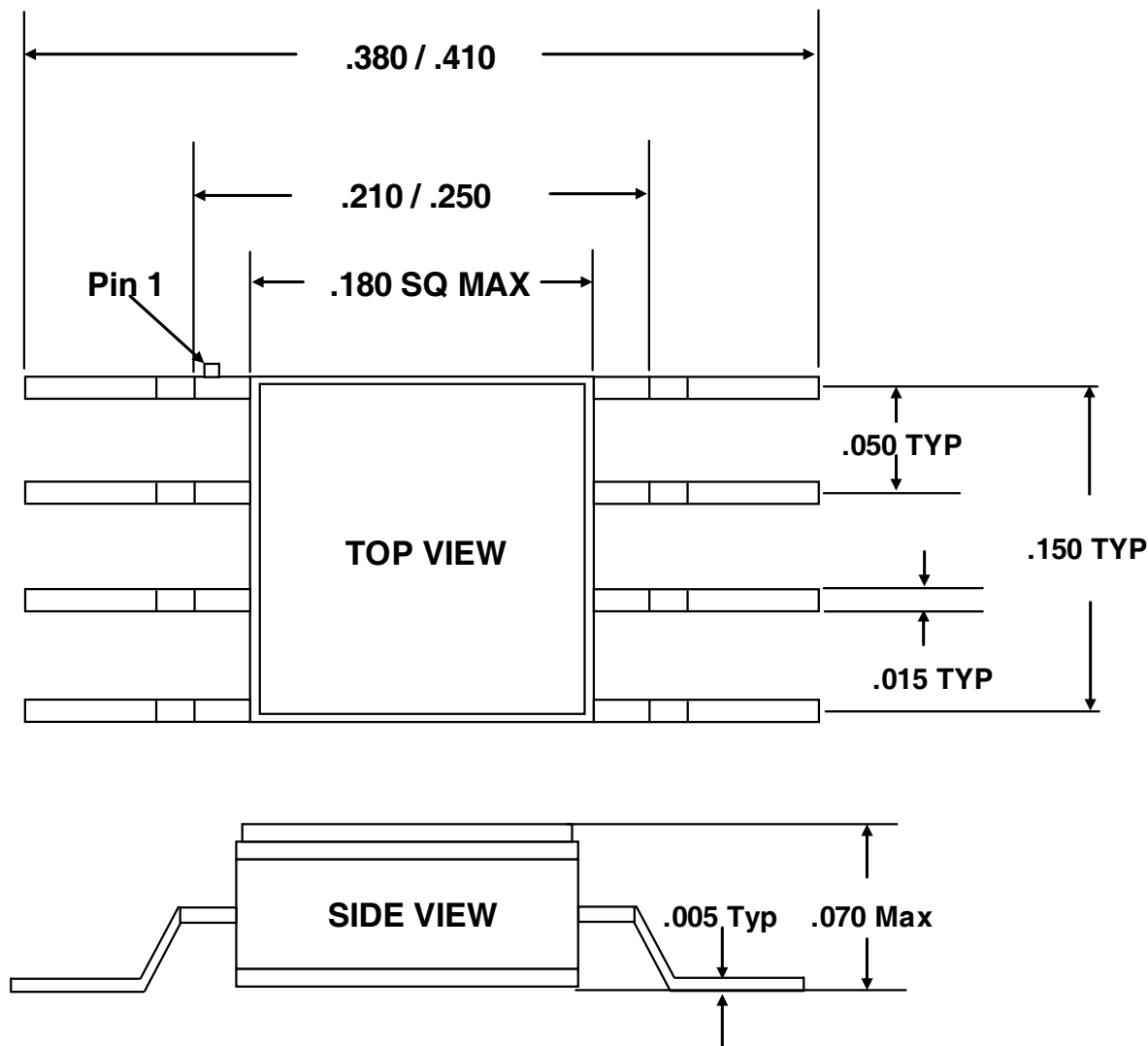

Figure 10. Package Drawing
8-lead CSOIC



ALL DIMENSIONS ARE IN INCHES
DRAWINGS ARE NOT TO SCALE

19-0028-01

Figure 11. Top Marking Specifications

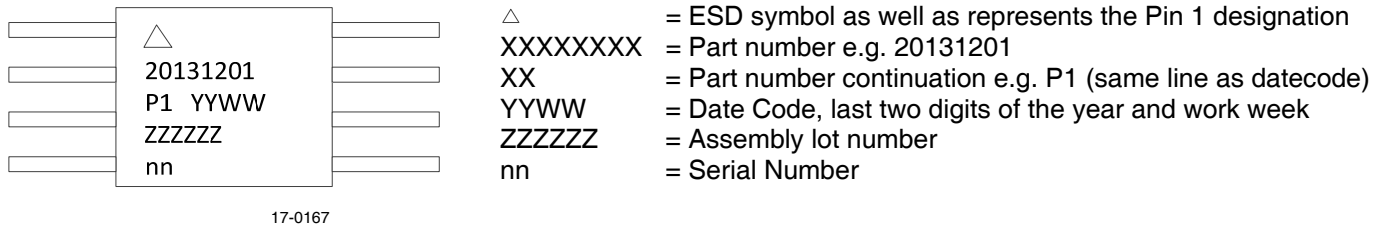

Table 4. Ordering Information

Order Code	Description	Package	Shipping Method
9303-01	PE9303-08CFPJ-B Engineering Samples	8-lead FLAT PACK	50 / Tray
9303-11	PE9303-08CFPJ-B Production Units	8-lead FLAT PACK	50 / Tray
9303-98	Engineering sample die with bonding X (X = A - H)	Die	49 units / Waffle Pack
9303-99	Flight die with bonding X (X = A - H)	Die	49 units / Waffle Pack
9303-00	PE9303 Evaluation Kit	Evaluation Board	1 / Box

Sales Contact and Information

For sales and contact information please visit www.psemi.com.

Advance Information: The product is in a formative or design stage. The datasheet contains design target specifications for product development. Specifications and features may change in any manner without notice.

Preliminary Specification: The datasheet contains preliminary data. Additional data may be added at a later date. Peregrine reserves the right to change specifications at any time without notice in order to supply the best possible product. **Product Specification:** The datasheet contains final data. In the event Peregrine decides to change the specifications, Peregrine will notify customers of the intended changes by issuing a CNF (Customer Notification Form).

The information in this datasheet is believed to be reliable. However, Peregrine assumes no liability for the use of this information. Use shall be entirely at the user's own risk.

No patent rights or licenses to any circuits described in this datasheet are implied or granted to any third party. Peregrine's products are not designed or intended for use in devices or systems intended for surgical implant, or in other applications intended to support or sustain life, or in any application in which the failure of the Peregrine product could create a situation in which personal injury or death might occur. Peregrine assumes no liability for damages, including consequential or incidental damages, arising out of the use of its products in such applications.

The Peregrine name, logo, UltraCMOS and UTSi are registered trademarks and HaRP, MultiSwitch and DuNE are trademarks of Peregrine Semiconductor Corp.