

8932-A

VOICE-COIL MOTOR DRIVER

Providing control and drive of the voice-coil motor used for head positioning in 5 V disk drive applications, the second-generation A8932CLWA is a full-bridge driver that can be configured so that its output current is a direct function of an externally applied control voltage or current. This linear current control function is supplemented by additional circuitry to protect the heads and the data disk during system failure or normal system shutdown.

The two ± 500 mA MOS driver outputs provide very low saturation voltage and minimal power dissipation. Additional headroom is achieved by the sense-FET structure eliminating the need for an external current-sense resistor. Internal circuitry can be configured to provide closed-loop velocity control of the actuator by utilizing the generated back-EMF of the voice-coil motor. Thermal protection and under-voltage lockout disables the system in a controlled sequence if a fault condition occurs.

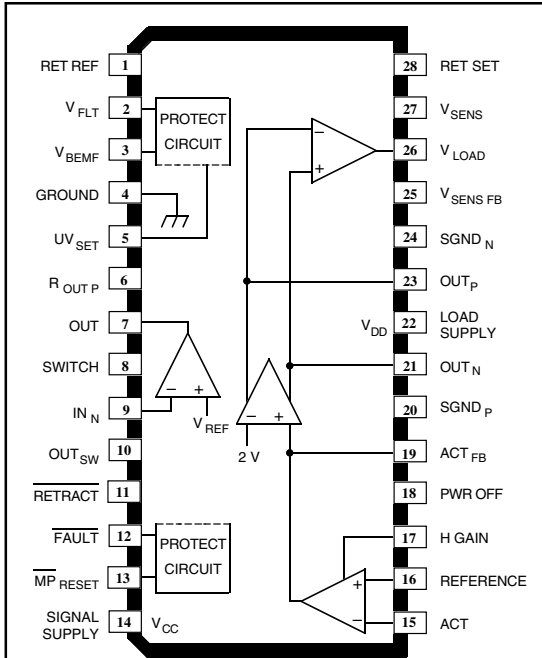

Dwg. PP-042B

ABSOLUTE MAXIMUM RATINGS

Supply Voltages, V_{CC} and V_{DD}	6.0 V
Output Current, I_{OUT} (peak)	± 600 mA
(continuous)	± 500 mA
Analogue Input Voltage Range,	
V_{IN}	-0.3 V to V_{CC}
Logic Input Voltage Range,	
V_{IN}	-0.3 V to +6.0 V
Package Power Dissipation,	
P_D	See Graph
Operating Temperature Range,	
T_A	0°C to +70°C
Junction Temperature, T_J	+150°C†
Storage Temperature Range,	
T_S	-55°C to +150°C

† Fault conditions that produce excessive junction temperature will activate device thermal shutdown circuitry. These conditions can be tolerated, but should be avoided.

Output current rating may be restricted to a value determined by system concerns and factors. These include: system duty cycle and timing, ambient temperature, and use of any heatsinking and/or forced cooling. For reliable operation the specified maximum junction temperature should not be exceeded.

FEATURES

- Class-B, $2 \Omega r_{DS(on)}$ at 500 mA Output
- Lossless Current Sensing
- Zero Current-Loop Deadband
- High Transconductance Bandwidth
- User-Adjustable Transconductance Gain
- Digital Transconductance Gain Switch (4:1 Ratio)
- 5 Volt Monitor with Selectable UV Trip Point
- Retract Circuitry Functional to 0 Volts
- Sleep Mode Function
- Internal Back-EMF Velocity Loop Option
- Internal Thermal Shutdown Circuitry

Always order by complete part number, e.g., **A8932CLWA**.

8932-A VOICE-COIL MOTOR DRIVER

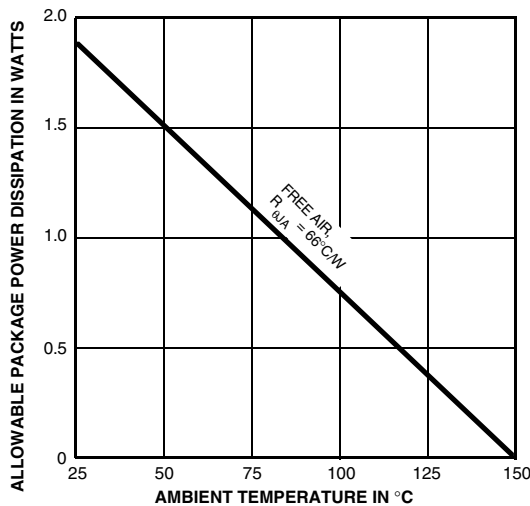
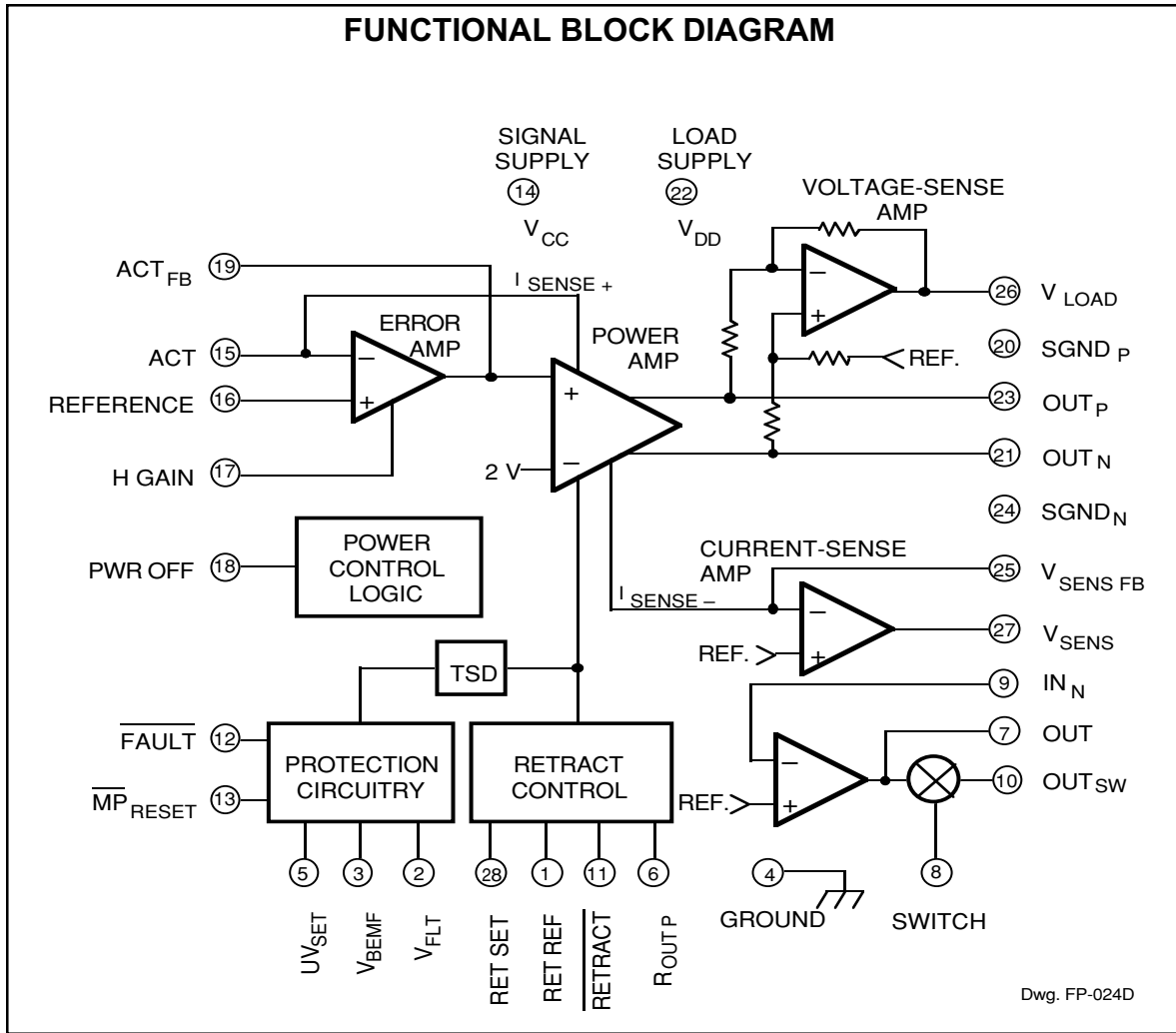

8932-A VOICE-COIL MOTOR DRIVER

ELECTRICAL CHARACTERISTICS at $T_A = +25^\circ\text{C}$, $V_{CC} = V_{DD} = 5.0\text{ V}$, $V_{REF} = V_{IN} = 2.0\text{ V}$,
Load = $150\ \mu\text{H}/3.5\ \Omega$ (unless otherwise noted).

Characteristic	Symbol	Test Conditions	Limits			
			Min.	Typ.	Max.	Units
Error Amplifier						
Input Offset Voltage	V_{IO}	$I_{LOAD} = 0\text{ mA}$	—	—	± 50	mV
Current Gain	A_{iH}	H GAIN $\geq 3.5\text{ V}$	7200	8000	8800	—
	A_{iL}	H GAIN $\leq 0.7\text{ V}$	1800	2000	2200	—
Current Gain Linearity	$E_{L(adj)}$	$I_{OUT} = 5\text{ mA to } 500\text{ mA}$, $A_i = A_{iL}$	—	—	± 10	%
		$I_{OUT} = 5\text{ mA to } 500\text{ mA}$, $A_i = A_{iH}$	—	—	± 10	%
Reference Voltage Range	V_{REF}		1.5	—	2.5	V
Voltage-Sense Amplifier						
Voltage Gain	A_{VD}		0.36	0.40	0.44	—
Output Offset Voltage	V_{OO}	$I_{LOAD} = 0\text{ mA}$	—	—	± 25	mV
Current-Sense Amplifier						
Amplifier Error	E_{VD}	$(R_s \times I_{LOAD} / (A_i \times V_{SENSE})) - 1$	—	1.0	—	—
Input Offset Voltage	V_{IO}	$I_{LOAD} = 0\text{ mA}$, $A_i = A_{iL}$	—	—	± 25	mV
Output Drivers						
Total On Resistance (Source + Sink)	$r_{DS(on)}$	$I_{LOAD} = 100\text{ mA}$	—	2.0	2.5	Ω
		$I_{LOAD} = 500\text{ mA}$	—	2.0	2.5	Ω
Retract Output Voltage Error	$E_{OUT(PN)}$	$V_{OUT(P)} - V_{OUT(N)} - V_{RESET}$	—	—	± 100	mV
Full Power Bandwidth	BW	-3 dB	1.0	—	—	kHz
Uncommitted Op Amp						
Voltage Gain	A_{VS}		—	91	—	dB
Unity Gain Bandwidth	BW		—	1.0	—	MHz
Max. Load Capacitance	C_{LOAD}		—	40	—	pF
Slew Rate	SR		—	4.2	—	V/ μs
Output Voltage	V_O	$V_{SWITCH} \leq 0.7\text{ V}$	2.5	—	3.5	V
	V_{OSW}	$V_{SWITCH} \geq 3.5\text{ V}$	2.5	—	3.5	V
Max. Output Current	I_O		—	± 250	—	μA
Input Offset Voltage	V_{IO}		—	$< \pm 10$	—	mV

Continued next page...

Negative current is defined as coming out of (sourcing) the specified device terminal.
Typical Data is for design information only.

8932-A

VOICE-COIL MOTOR DRIVER

ELECTRICAL CHARACTERISTICS at $T_A = +25^\circ\text{C}$, $V_{CC} = V_{DD} = 5.0\text{ V}$, $V_{REF} = V_{IN} = 2.0\text{ V}$, Load = $150\ \mu\text{H}/3.5\ \Omega$ (unless otherwise noted).

Characteristic	Symbol	Test Conditions	Limits			
			Min.	Typ.	Max.	Units
Miscellaneous						
Supply Voltage	V_{CC}	Operating	4.5	5.0	5.5	V
	V_{DD}	Operating	4.5	5.0	5.5	V
Under-Voltage Lockout Voltage	V_{CC}	$V_{CC} = V_{DD}$	3.9	4.2	4.35	V
Fault Logic Output	V_{FAULT}	$V_{RETRACT} \geq 3.5\text{ V}$	—	—	500	mV
		$V_{RETRACT} \leq 0.7\text{ V}$	4.5	—	—	V
	I_{FAULT}	$V_{FLT} = 2.25\text{ V}$	—	>20	—	μA
Power-On Reset	$V_{MPRESET}$	$V_{RETRACT} \geq 3.5\text{ V}$	4.5	—	—	V
		$V_{RETRACT} \leq 0.7\text{ V}$, $I_{MPREST} = 1.5\text{ mA}$	—	—	800	mV
Total Supply Current	$I_{CC} + I_{DD}$	Outputs Balanced, No Load	—	—	10	mA
		Sleep Mode, PWR OFF = V_{CC}	—	—	2.0	mA
Logic Input Voltage	$V_{IN(0)}$		—	—	0.7	V
	$V_{IN(1)}$		3.5	—	—	V
Thermal Shutdown Temperature	T_J		—	165	—	$^\circ\text{C}$
Thermal Shutdown Hysteresis	ΔT_J		—	20	—	$^\circ\text{C}$

Negative current is defined as coming out of (sourcing) the specified device terminal.

Typical Data is for design information only.

The products described here are manufactured under one or more U.S. patents or U.S. patents pending.

Allegro MicroSystems, Inc. reserves the right to make, from time to time, such departures from the detail specifications as may be required to permit improvements in the performance, reliability, or manufacturability of its products. Before placing an order, the user is cautioned to verify that the information being relied upon is current.

Allegro products are not authorized for use as critical components in life-support devices or systems without express written approval.

The information included herein is believed to be accurate and reliable. However, Allegro MicroSystems, Inc. assumes no responsibility for its use; nor for any infringement of patents or other rights of third parties which may result from its use.



8932-A VOICE-COIL MOTOR DRIVER

TERMINAL FUNCTIONS

Term.	Terminal Name	Function
1	RET REF	The reference supply for setting the voltage across the load during retract.
2	V_{FLT}	Reservoir (energy storage) capacitor used to operate fault circuitry.
3	V_{BEMF}	Back-EMF voltage from spindle motor used to retract heads during loss of power.
4	GROUND	Circuit reference.
5	UV_{SET}	Under-voltage trip point reference UV input. Set internally to 4.2 V but may be overridden by external resistor divider. (Equation 4).
6	$R_{OUT P}$	Source driver used for retract; externally connected to OUT_P .
7	OUT	Output of uncommitted operational amplifier.
8	SWITCH	Logic input for transmission gate; a high level connects OUT to OUT_{SW} .
9	IN_N	Inverting input to uncommitted operational amplifier.
10	OUT_{SW}	Transmission-gated output of uncommitted operational amplifier.
11	RETRACT	An active-low logic input that initiates the retract sequence.
12	FAULT	A logic low at this MOS output indicates a thermal shutdown, under-voltage fault, or retract command.
13	MP_{RESET}	(Power-On Reset) A logic low at this open-collector output may be used to reset the system on under-voltage fault or power on.
14	SIGNAL SUPPLY	V_{CC} ; low-current supply voltage in the range of 4.5 V to 5.5 V.
15	ACT	Input which controls the current in the load. Transconductance gain is set with an external resistor in series with this input (Equation 1).
16	REFERENCE	V_{REF} ; reference input for all amplifiers; ac ground.
17	H GAIN	Logic input to switch the error amplifier transconductance gain: LOW = 2000, HIGH = 8000.
18	PWR OFF	An active-high logic input that puts the device in a “sleep mode”. All fault circuitry remains active.
19	ACT_{FB}	Input connection for feedback network which sets the error amplifier gain and bandwidth.
20	$SGND_P$	Power ground for the OUT_P sink driver.
21	OUT_N	Power output. Sinks current when $V_{ACT} < V_{REF}$.
22	LOAD SUPPLY	V_{DD} ; high-current supply voltage for the voice-coil motor.
23	OUT_P	Power output. Sinks current when $V_{ACT} > V_{REF}$.
24	$SGND_N$	Power ground for the OUT_N sink driver.
25	$V_{SENS FB}$	Input connection for feedback network which sets the current-sense amplifier gain and bandwidth. Also called gm SET.
26	V_{LOAD}	An output voltage proportional to the load voltage. Used in conjunction with closed-loop velocity control.
27	V_{SENS}	Voltage output representing load current (Equation 2). Also called MONITOR.
28	RET SET	An external resistor divider to set the retract voltage across the load. Used in conjunction with $V_{RET-REF}$ (Equation 3).

8932-A VOICE-COIL MOTOR DRIVER

DEVICE DESCRIPTION

Current Amplifier. The A8932CLWA voice-coil motor driver features a wide transconductance bandwidth and minimal crossover distortion. The transconductance gain is user selectable:

$$g_m = \frac{A_i}{R_{gm}} \quad (\text{Equation 1})$$

where A_i is either 2000 (H GAIN = Low) or 8000 (H GAIN = High).

The error amplifier's bandwidth and load compensation zero are set utilizing external resistor and capacitor feedback components around the amplifier.

The actuator main loop compensation can be set by applying a square wave and adjusting R_z and C_z for optimum response.

Current and Voltage Sensing. The load current is sensed internally. Three auxiliary amplifiers are also included to allow various control functions to be implemented. The first of these amplifiers provides a voltage output that is proportional to the load current:

$$V_{\text{SENSE}} = \frac{R_s I_{\text{LOAD}}}{A_i} \quad (\text{Equation 2})$$

The second and third auxiliary amplifiers may be used in conjunction with the first to provide a closed-loop velocity control system for the actuator arm during a controlled retract for head parking. This is achieved by determining the back-EMF voltage generated by the voice coil and feeding back this information to the main actuator control input. The back-EMF feedback voltage can be switched in as required by means of the SWITCH logic input.

The back-EMF voltage represents the velocity of the actuator. By subtracting the $I_{\text{LOAD}} R_{\text{LOAD}}$ voltage component from the voltage across the load, the back-EMF term can be isolated and fed back to close a velocity control loop.

The amplifier output voltage V_{LOAD} is proportional to the voltage across the load ($A_{\text{VD}}[V_{\text{OUTN}} - V_{\text{OUTP}}]$). R_s is selected so that V_{SENSE} represents I_{LOAD} while R_3 is dependent on R_{LOAD} as shown in the following equations:

$$V_{\text{LOAD}} = -A_{\text{VD}} (I_{\text{LOAD}} R_{\text{LOAD}}) + V_{\text{BEMF}}$$

$$V_{\text{SENSE}} = R_s I_{\text{LOAD}} / A_{\text{IL}}$$

where $A_i = 2000$ (H GAIN = logic Low)

$$\text{OUT}_{\text{SW}} = 0.4 (V_{\text{BEMF}} R_1 / R_2)$$

$$R_3 = \frac{R_2 R_s}{0.4 A_i R_{\text{LOAD}}}$$

$$\frac{V_{\text{BEMF}}}{V_{\text{IN}}} = \frac{R_2 R_{\text{Vgm}}}{0.4 R_{\text{gm}} R_1}$$

$$\text{BW} = 0.4 \frac{R_1 K_B K_T A_i}{2\pi R_{\text{VGM}} R_2 J}$$

where J is the moment of inertia, K_B is the back-EMF motor constant, and K_T is the torque constant.

Velocity loop compensation = $L_{\text{LOAD}} / R_{\text{LOAD}} = R_1 C_1 = R_3 C_2$.

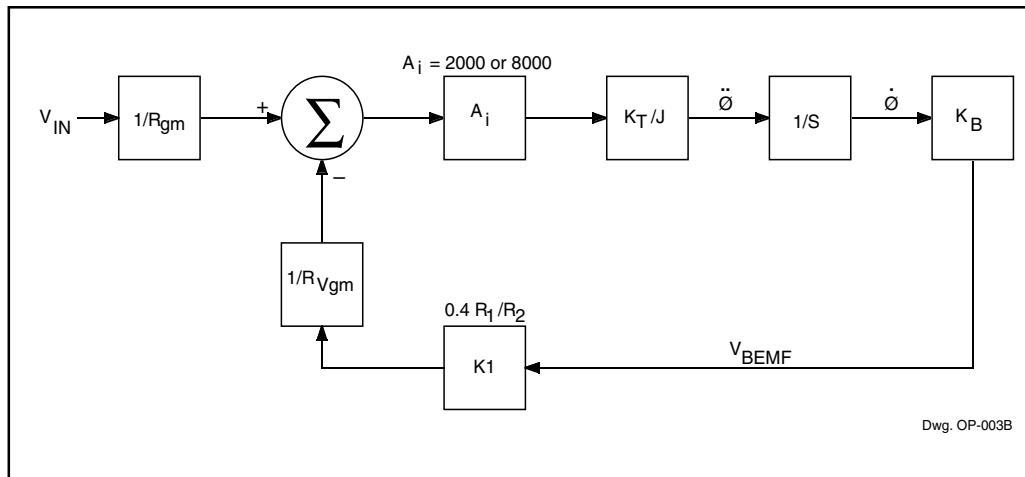

8932-A VOICE-COIL MOTOR DRIVER

Retract and Brake. A retract-brake sequence is initiated on receiving a fault indication from the internal thermal shutdown (TSD), or under-voltage lockout (UVLO), or an externally applied logic High at the RETRACT input.

If the velocity control scheme is implemented, the head can be retracted under the full control of V_{IN} in conjunction with OUT_{SW} back-EMF voltage if no fault condition exists. If a fault condition were to occur however, the retract velocity would be controlled by applying a constant user-defined voltage across the load:

$$V_{RET-SET} = \frac{2 R_8}{1000 + R_7 + R_8} \quad (\text{Equation 3})$$

where $R_7 + R_8 \gg 1000 \Omega$.

When the sequence is operated, the output voltage is forced to approximately $V_{RET-SET}$ to retract the heads, and then a fault command ("brake") is sent to the spindle motor driver. The user determines the total time for the retract sequence, before the spindle brake is enabled, by the choice of an external resistor and capacitor at the FAULT output.

Power for the retract function is provided by the rectified back EMF of the spindle motor by way of the V_{BEMF} terminal. The A8932CLWA will perform the retract function under low supply conditions (nominally down to 2 V). Operation down to almost 0 V requires an energy-storage capacitor at the V_{FLT} terminal.

Protective Features. The A8932CLWA has a number of protective features incorporated into the design. Under-voltage lockout provides system protection in the event of reduced primary supply voltages. The under-voltage trip point is internally set at approximately 4.2 V. It can be user-defined with an external resistor voltage divider:

$$UV_{TRIP} = \frac{2 (R_5 + R_6)}{R_6} \quad (\text{Equation 4})$$

where $R_5 + R_6 \ll 200 \text{ k}\Omega$.

Thermal shutdown circuitry is included to protect the device from excessive junction temperature. It is only intended to protect the chip from catastrophic failures due to excessive junction temperature.

TEST CIRCUIT AND TYPICAL APPLICATION

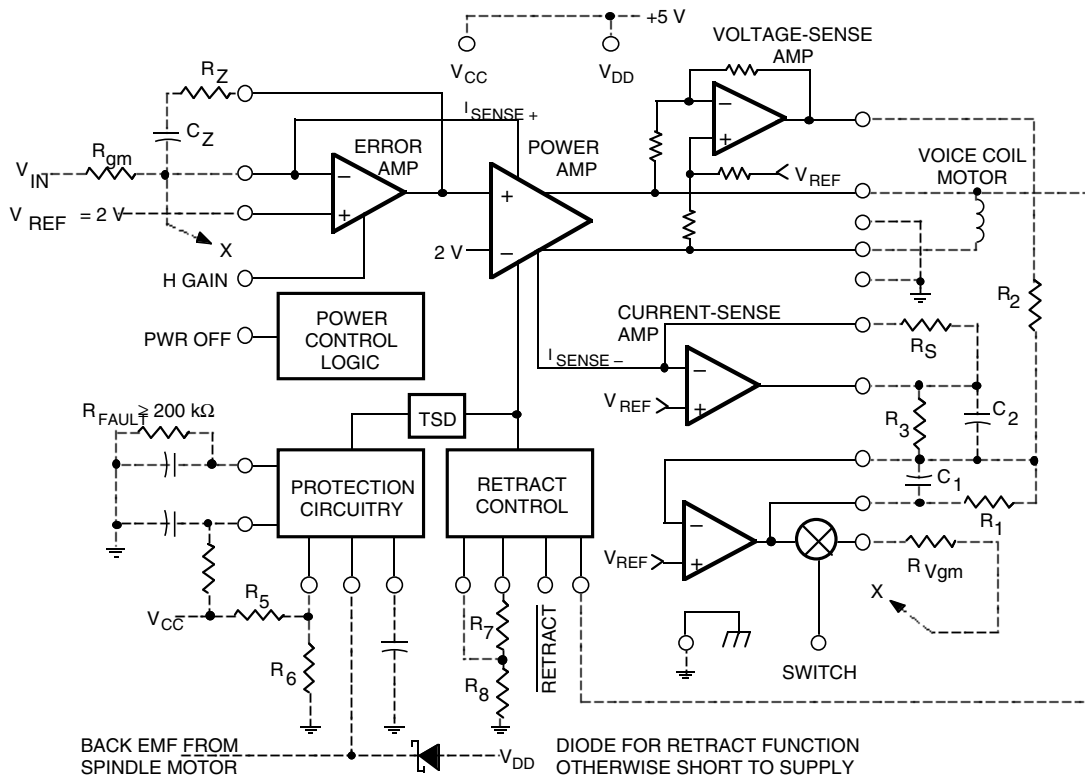

Dwg. EP-041D

8932-A VOICE-COIL MOTOR DRIVER

Dimensions in Inches (for reference only)

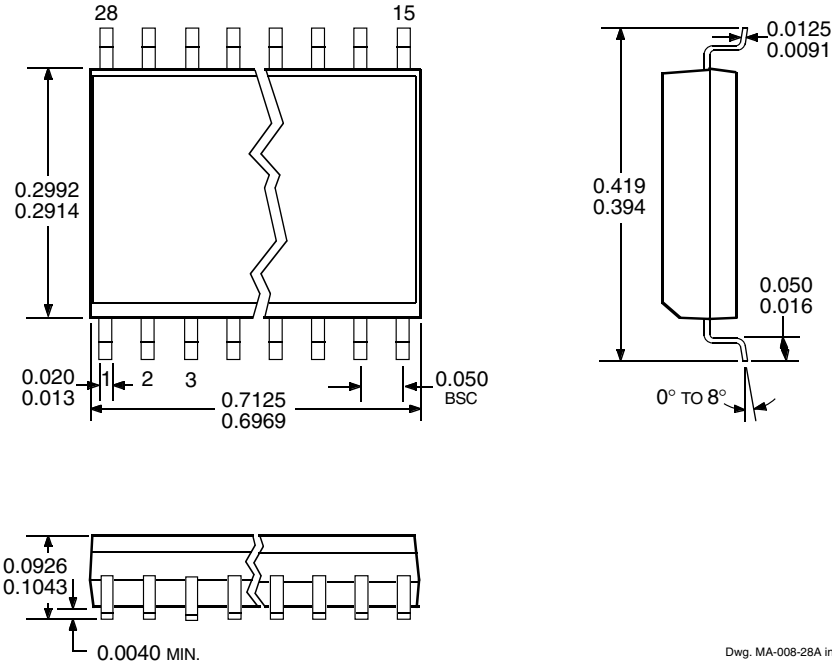

Dimensions in Millimeters (controlling dimensions)

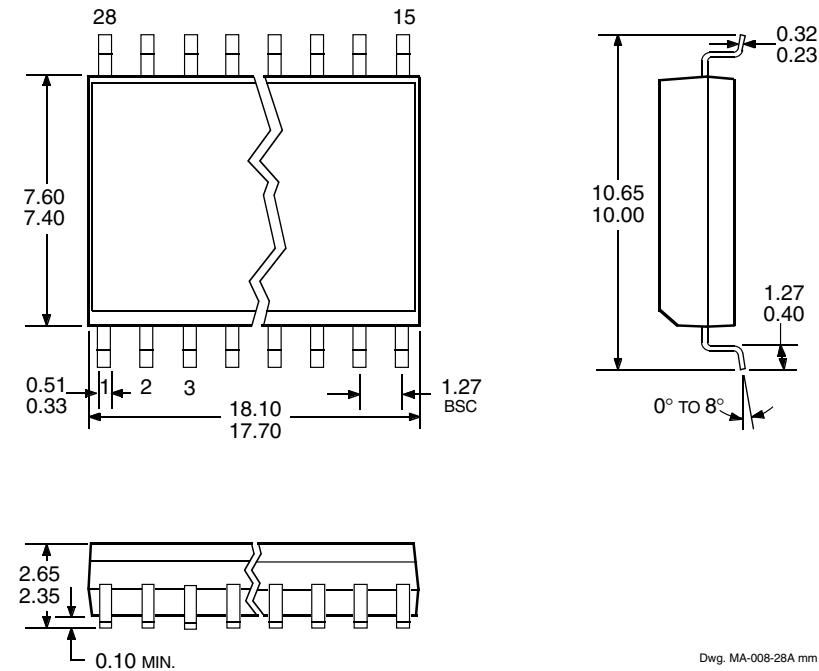

- NOTES:
1. Lead spacing tolerance is non-cumulative.
 2. Exact body and lead configuration at vendor's option within limits shown.
 3. Supplied in standard sticks/tubes of 27 devices or add "TR" to part number for tape and reel.