



DONGYA ELECTRONIC



ZLJM-250D

Series contactors
系列接触器

产品型号含义 Nomination(nomogram)

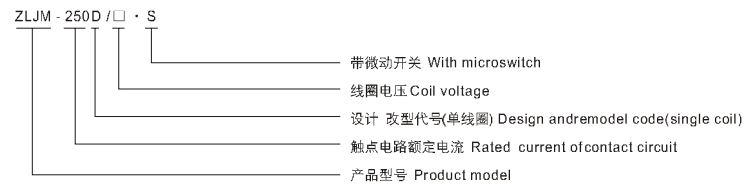

使用条件 Use conditions required

环境温度 Ambient temperature: -25~+40°C

相对湿度 Relative humidity: +20°C达98%(upto 98% at +20°C)

固定处的振动频率 Vibration freq. at the fixed position:

3g, 1~50Hz 振幅 0.5mm

3g, 1~50Hz ampl 0.5mm

安装方向 Mounting directions:

触点向上及水平位置

The contactors can be mounted vertically or horizontally, if mounted vertically the coil should be at the bottom

外形安装图 Configurational mounting diagram

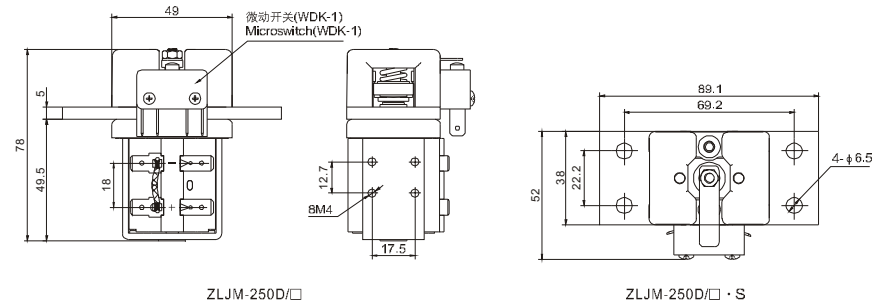

线路原理图 Circuit diagram

一路常开型 (SPSTN.O.)
3, 4为触点接线端(3, 4 contact terminal)
1, 2为线圈接线端(1, 2 coil terminal)
L为绕阻(L is winding)

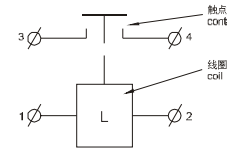

一路常开型 (SPSTN.O.)
带微动开关 (With Microswitch)
3, 4为触点接线端(3, 4 contact terminal)
1, 2为线圈接线端(1, 2 coil terminal)
L为绕阻(L is winding)
A, B, C, D为微动开关接线端(A, B, C, D aux. contact terminal)

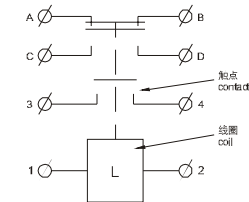

简要技术数据 Basic technical data

编号 NO.	参数名称 Parameters	产品代号 Product code	
		ZLJM-250D系列 Series	
1	线圈额定电压 Rated coil volt(VDC)	12, 24, 30, 48, 60, 72, 120等(etc)	
2	线圈功耗 Coil Power dissipation(W)	13-20	
3	触点电路额定电压 Rated volt of contact circuit(V DC)	60	
4	触点电路额定负载电流 Rated load current of contact circuit(A)	250A	
5	(20±5)°C下, 冷态动作电压(V) Operating volt in cold state at(20±5)°C	吸合 Pick-up	不大于线圈额定电压的70% Not above 70% of rated coil volt
		释放 Release	线圈额定电压的(5-30)% (5-30)% of rated coil volt
6	额定电压下最大动作时间(ms)(线圈不带抑制电器) Max. operating time at rated volt(ms) (Coil with no suppression circuit)	40	
7	抗电强度 Puncture(volt) strength	50Hz 1000V AC 1min	
8	100A负载下主触点接触电压降 Contact volt drop of main contact at 100A	不大于80mV not above 80mV	
9	电寿命 Electric life	20,000 Ops	
10	机械寿命 Mechanical life	10万次 100,000 Ops.	
11	工作规范 Working duty	连续 Continuous	