

REV	DESCRIPTION	BY DATE	APPD
01	REVISED PER ER30096	DRK 01/10/11	XXX

NOTES: UNLESS OTHERWISE SPECIFIED

- INTERFACE COMPLIANT TO SMPTE 304 SPECIFICATION.
- MATERIAL SPECIFICATIONS:
CONTACTS: COPPER ALLOY
O-RINGS AND STRAIN RELIEF: SILICONE RUBBER
ALL PLASTIC PARTS: 20% GLASS FILLED POLYPROPYLENE
ALL OTHER METAL PARTS: 303 STAINLESS STEEL PER ASTM A582
- FINISH SPECIFICATIONS:
STAINLESS STEEL PARTS: PASSIVATE
CONTACTS: .000100 MIN GOLD PER ASTM B488 OVER
.000080 MIN NICKEL PER AMS-QQN-290 (ROHS)
- ELECTRICAL SPECIFICATIONS:
LOW VOLTAGE CONTACTS: 42 - 60 VAC, 1 AMP
AUX ELECTRICAL CONTACTS: 600 VAC, 10 AMP
- ENVIRONMENTAL:
OPERATING TEMPERATURE RATING: -40°C TO 75°C
NON-OPERATING/STORAGE TEMPERATURE RATING: -40°C TO 85°C
HUMIDITY: <95 RH (AT 40°C)
- OPTICAL:
WAVELENGTH: 1250nm - 1625nm
INSERTION LOSS: 0.3dB TYPICAL, 0.5dB MAX
RETURN LOSS: > -45dB, -50dB TYPICAL
- REPLACEMENT KITS:
CONTACT KIT: 7760-000-00702Z
- CABLE PREPARATION AND STRIPPING PROCEDURE: CAP-TBD.
- RED LDPE DUST CAP INCLUDED (NOT SHOWN)
- CRIMP TOOLING:
FOR FACTORY APPLICATION USE HAND TOOL KTH-1000 AND DIE KTH-2035
FOR FIELD APPLICATION USE HAND TOOL KTH-5000 AND DIE KTH-5018
- ELECTRICAL AND OPTICAL CONTACTS INCLUDED

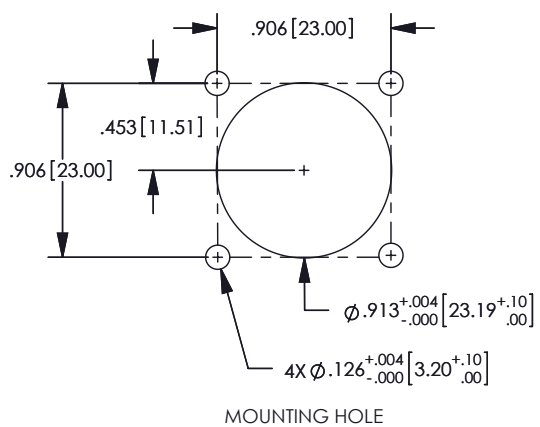
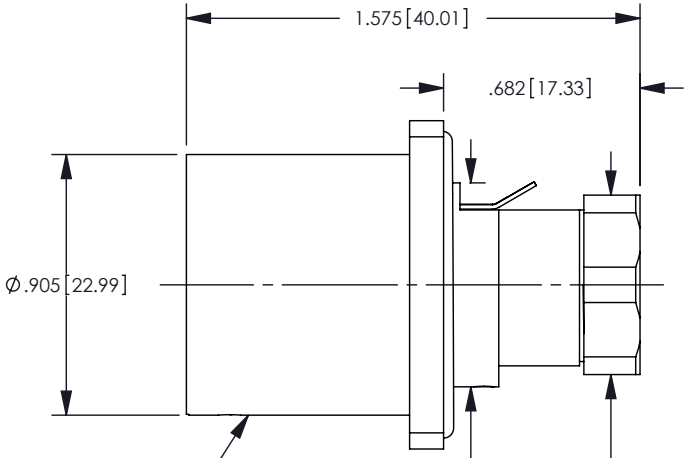
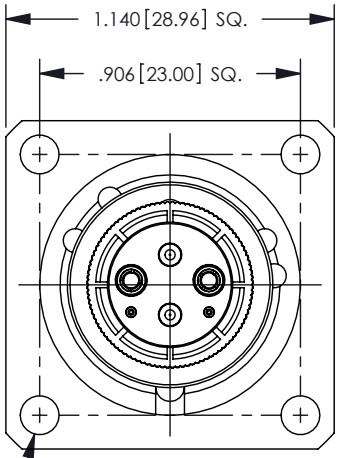
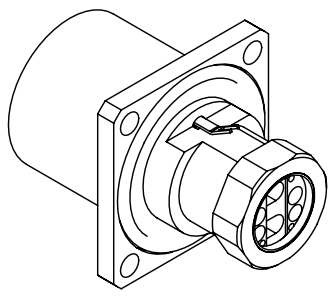

4X Ø.135 [3.43]

MARK: KINGS 7763-400-F1101P

5/8" [15.88] ACROSS FLATS

CATALOG P/N: 7763-400-F1101P

PER ASME Y14.5M-1994 UNLESS OTHERWISE SPECIFIED: DIMENSIONS ARE IN INCHES [MM] TOLERANCES: DECIMAL: .XX [X.X] ± .01 [0.3] .XXX [X.XX] ± .005 [0.13] .XXXX [X.XXX] ± .XXXX				THIRD ANGLE	
ANGLES: ± 2°				SCALE: 3:2	
CUSTOMER SALES DRAWING				TRI LOCK SMPT PANEL MOUNT 4 HOLE, JACK	
DRAWN	DATE	APPROVED	DATE		
DRK	01/10/11	PSM	02/01/11		
APPROVED	DATE	APPROVED	DATE		
JCF	02/01/11	XXX	XX/XX/XX		

KINGS
by WINCHESTER
Winchester Electronics Corporation
62 Barnes Industrial Road North
Wallingford, Connecticut 06492

A	SD7763-400-F1101P	SHT	OF	REV
		1	1	01