

# Glass Passivated Junction Transient Voltage Suppressor

## Stand-Off Voltage - 5.0 to 250 Volts

## 5000 Watt Peak Pulse Power

### Features

- Plastic package
- Glass passivated chip junction
- 5000W Peak Pulse Power capability on 10/1000 $\mu$ s waveform
- Excellent clamping capability
- Repetition rate (duty cycle):0.05%
- Low incremental surge resistance
- Fast response time: typically less than 1.0ps from 0 Volts to  $B_V$  min.
- Typical  $I_R$  less than 2 $\mu$ A above 10V
- High temperature soldering guaranteed: 265 $^{\circ}$ C/10 seconds/.375", (9.5mm) lead length, 5lbs., (2.3kg) tension
- Pb-free plated

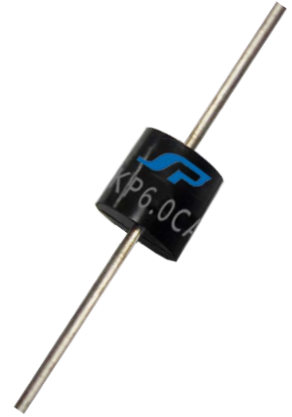

### Mechanical Data

- **Case:** Molded plastic over glass passivated junction
- **Terminals:** Solderable per MIL-STD-750, Method 2026
- **Polarity:** Color band denotes positive end (cathode) except Bipolar
- **Mounting Position:** Any
- **Weight:** 0.07 ounce, 2.1 grams

### Devices For Bipolar Application

- For Bidirectional use C or CA Suffix for types 5KP5.0 thru types 5KP250 (e.g. 5KP5.0C, 5KP250CA)
- Electrical characteristics apply in both directions

### Maximum Ratings And Characteristics

Ratings at 25 $^{\circ}$ C ambient temperature unless otherwise specified.

RATING	SYMBOL	VALUE	UNITS
Peak Pulse Power Dissipation on 10/1000 $\mu$ s waveform (Note 1, FIG.1)	$P_{PPM}$	Minimum 5000	Watts
Peak Pulse Current of on 10/1000 $\mu$ s waveform (Note 1, FIG.3)	$I_{PPM}$	SEE TABLE 1	Amps
Steady State Power Dissipation at $T_L = 75^{\circ}$ C, Lead lengths. 375", (9.5mm) (Note 2)	$P_{M(AV)}$	8	Watts
Peak Forward Surge Current, 8.3ms Single Half Sine-Wave Superimposed on Rated Load, (JEDEC Method) (Note3)	$I_{FSM}$	400	Amps
Operating junction and Storage Temperature Range	$T_J, T_{STG}$	-55 to +175	$^{\circ}$ C

#### Notes :

1. Non-repetitive current pulse, per Fig. 3 and derated above  $T_A = 25^{\circ}$ C per Fig. 2.
2. Mounted on Copper Pad area of 0.8 $\times$ 0.8" (20 $\times$ 20mm) per Fig. 5
3. 8.3ms single half sine-wave, or equivalent square wave, Duty cycle = 4 pulses per minutes maximum.

## Dimensions

Case Style P600

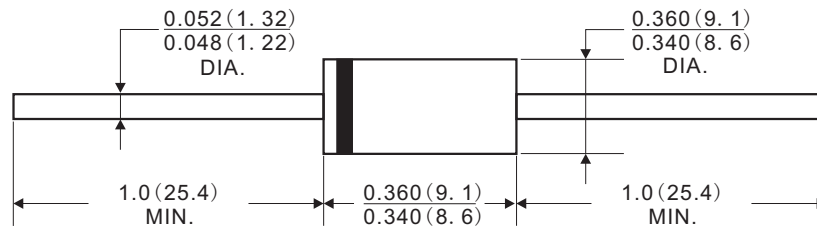

Dimensions in inches and (millimeters)

## Electrical Characteristics

TABLE 1

\*\*\*Stand for commonly used models

5KP Part Number		Reverse Stand-Off Voltage	Breakdown Voltage @IT	Breakdown Voltage @IT	Test Current	Maximum Clamping Voltage @Ipp	Peak Pulse Current	Reverse Leakage @VRWM
UNI-Polar	BI-Polar	VRWM(V)	VBR(V)Min.	VBR(V)Max.	IT(mA)	Vc(V)	Ipp(A)	IR(μA)
5KP5.0A	5KP5.0CA	5.0	6.40	7.00	50	9.2	554.3	5000
5KP6.0A	5KP6.0CA	6.0	6.67	7.37	50	10.3	495.1	5000
5KP6.5A	5KP6.5CA	6.5	7.22	7.98	50	11.2	455.4	2000
5KP7.0A	5KP7.0CA	7.0	7.78	8.60	50	12.0	425.0	1000
5KP7.5A	5KP7.5CA	7.5	8.33	9.21	5	12.9	395.3	250
5KP8.0A	5KP8.0CA	8.0	8.89	9.83	5	13.6	375.0	150
5KP8.5A	5KP8.5CA	8.5	9.44	10.40	5	14.4	354.2	50
5KP9.0A	5KP9.0CA	9.0	10.00	11.10	5	15.4	331.2	20
5KP10A	5KP10CA	10.0	11.10	12.30	5	17.0	300.0	15
5KP11A	5KP11CA	11.0	12.20	13.50	5	18.2	280.2	2
5KP12A	5KP12CA	12.0	13.30	14.70	5	19.9	256.3	2
5KP13A	5KP13CA	13.0	14.40	15.90	5	21.5	237.2	2
5KP14A	5KP14CA	14.0	15.60	17.20	5	23.2	219.8	2
5KP15A	5KP15CA	15.0	16.70	18.50	5	24.4	209.0	2
5KP16A	5KP16CA	16.0	17.80	19.70	5	26.0	196.2	2
5KP17A	5KP17CA	17.0	18.90	20.90	5	27.6	184.8	2
5KP18A	5KP18CA	18.0	20.00	22.10	5	29.2	174.7	2
5KP20A	5KP20CA	20.0	22.20	24.50	5	32.4	157.4	2
5KP22A	5KP22CA	22.0	24.40	26.90	5	35.5	143.7	2
* 5KP24A	5KP24CA	24.0	26.70	29.50	5	38.9	131.1	2
5KP26A	5KP26CA	26.0	28.90	31.90	5	42.1	121.1	2
5KP28A	5KP28CA	28.0	31.10	34.40	5	45.4	112.3	2

Notes :

1. For bidirectional type having VRWM of 10 volts and less, the IR limit is double
2. For parts with A, the VBR is ± 5%

Electrical Characteristics

TABLE 1

\*\*\*Stand for commonly used models

5KP Part Number		Reverse Stand-Off Voltage	Breakdown Voltage @IT	Breakdown Voltage @IT	Test Current	Maximum Clamping Voltage @Ipp	Peak Pulse Current	Reverse Leakage @VRWM
UNI-Polar	BI-Polar	VRWM(V)	VBR(V)Min.	VBR(V)Max.	IT(mA)	Vc(V)	Ipp(A)	IR(μA)
5KP30A	5KP30CA	30.0	33.30	36.80	5	48.4	105.4	2
* 5KP33A	* 5KP33CA	33.0	36.70	40.60	5	53.3	95.7	2
* 5KP36A	5KP36CA	36.0	40.00	44.20	5	58.1	87.8	2
5KP40A	5KP40CA	40.0	44.40	49.10	5	64.5	79.1	2
5KP43A	5KP43CA	43.0	47.80	52.80	5	69.4	73.5	2
5KP45A	5KP45CA	45.0	50.00	55.30	5	72.7	70.2	2
5KP48A	5KP48CA	48.0	53.30	58.90	5	77.4	65.9	2
5KP51A	5KP51CA	51.0	56.70	62.70	5	82.4	61.9	2
5KP54A	5KP54CA	54.0	60.00	66.30	5	87.1	58.6	2
5KP58A	5KP58CA	58.0	64.40	71.20	5	93.6	54.5	2
5KP60A	5KP60CA	60.0	66.70	73.70	5	96.8	52.7	2
5KP64A	5KP64CA	64.0	71.10	78.60	5	103.0	49.5	2
5KP70A	5KP70CA	70.0	77.80	86.00	5	113.0	45.1	2
5KP75A	5KP75CA	75.0	83.30	92.10	5	121.0	42.1	2
5KP78A	5KP78CA	78.0	86.70	95.80	5	126.0	40.5	2
5KP85A	5KP85CA	85.0	94.40	104.00	5	137.0	37.2	2
5KP90A	5KP90CA	90.0	100.00	111.00	5	146.0	34.9	2
5KP100A	5KP100CA	100.0	110.00	123.00	5	162.0	31.5	2
5KP110A	5KP110CA	110.0	122.00	135.00	5	177.0	28.8	2
5KP120A	5KP120CA	120.0	133.00	147.00	5	193.0	26.4	2
5KP130A	5KP130CA	130.0	144.00	159.00	5	209.0	24.4	2
5KP150A	5KP150CA	150.0	167.00	185.00	5	243.0	21.0	2
5KP160A	5KP160CA	160.0	178.00	197.00	5	259.0	19.7	2
5KP170A	5KP170CA	170.0	189.00	209.00	5	275.0	18.5	2
5KP180A	5KP180CA	180.0	200.00	222.00	5	289.0	17.5	2
5KP190A	5KP190CA	190.0	211.00	233.00	5	310.0	16.5	2
5KP200A	5KP200CA	200.0	222.00	246.00	5	329.2	15.5	2
5KP210A	5KP210CA	210.0	233.00	258.00	5	349.5	14.6	2
5KP220A	5KP220CA	220.0	244.00	270.00	5	371.1	13.7	2
5KP250A	5KP250CA	250.0	277.00	306.00	5	425.0	12.0	2

Notes :

- 1.For bidirectional type having VRWM of 10 volts and less, the IR limit is double
- 2.For parts with A , the VBR is ± 5%

Rating And Characteristic Curves

Fig.1 Peak Pulse Power Rating Curve

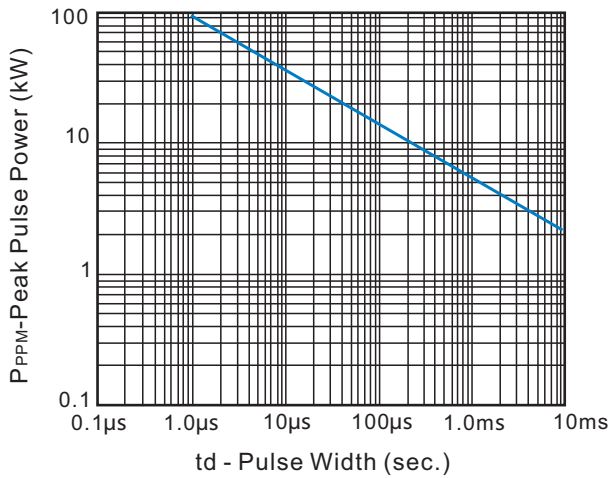

Fig.2 Pulse Derating Curve

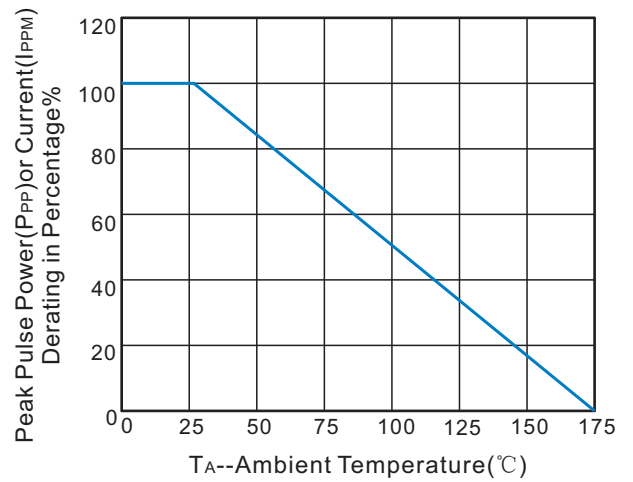

Fig.3 Pulse Waverform

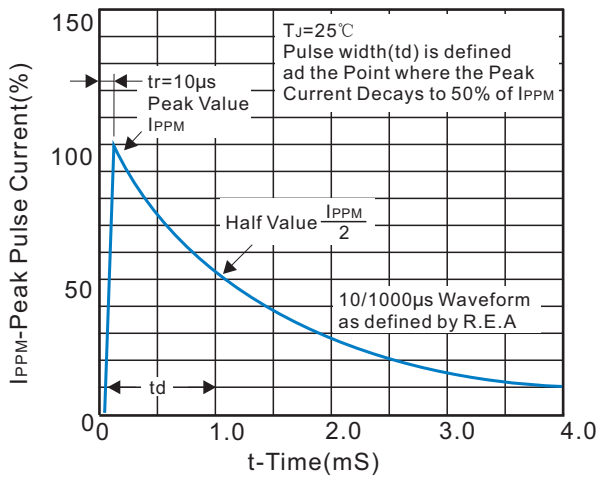

Fig.4 Typical Junction Capacitance

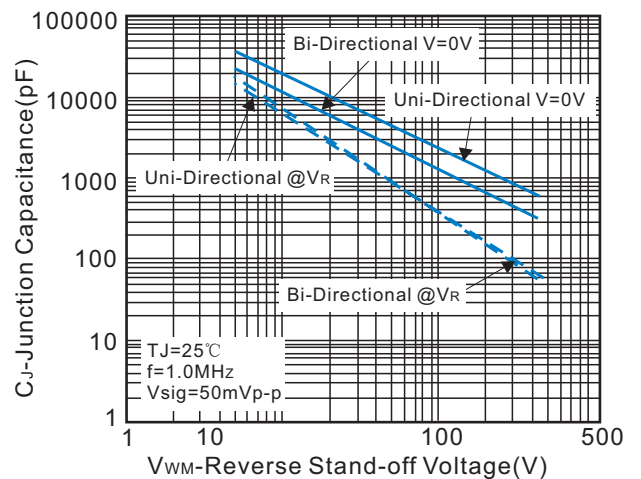

Fig.5 Steady State Power Dissipation Derating Curve

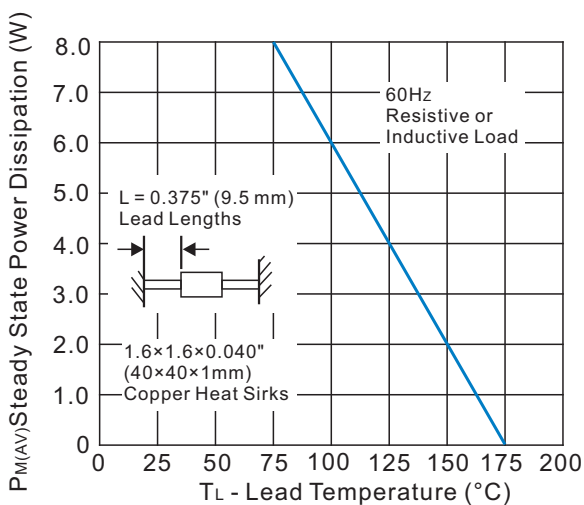
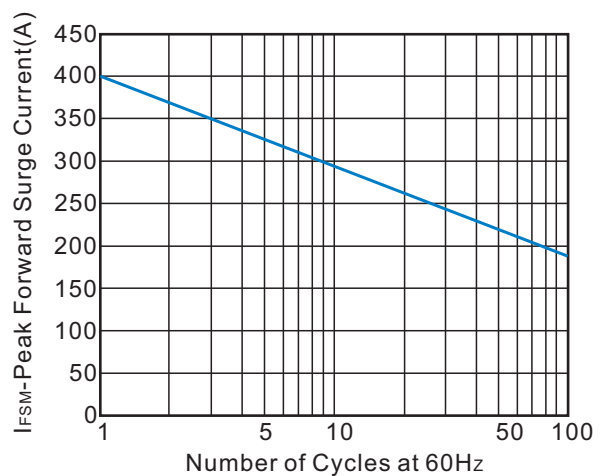

Fig.6 Maximum Non-Repetitive Peak Forward Surge Current



## Recommended Soldering Conditions

### Recommended Conditions

Reflow Condition		Pb-Free assembly (see Fig.1)
Pre Heat	-Temperature Min( $T_{s(min)}$ )	+150°C
	-Temperature Max( $T_{s(max)}$ )	+200°C
	-Time(Min to Max)( $t_s$ )	60-180secs
Average ramp up rate (Liquidus Temp( $T_L$ ) to peak)		3°C/sec.Max.
$T_{s(max)}$ to $T_L$ -Ramp-up Rate		3°C/sec.Max.
Reflow	-Temperature( $T_L$ )(Liquidus)	+217°C
	-Temperature( $t_L$ )	60-150secs
Peak Temp( $T_P$ )		+260(+0/-5)°C
Time within 5°C of actual Peak Temp( $t_P$ )		30 secs.Max.
Ramp-down Rate		6°C/sec.Max.
Time 25°C to Peak Temp( $T_P$ )		8 min.Max.
Do not exceed		+260°C

### Reflow Soldering

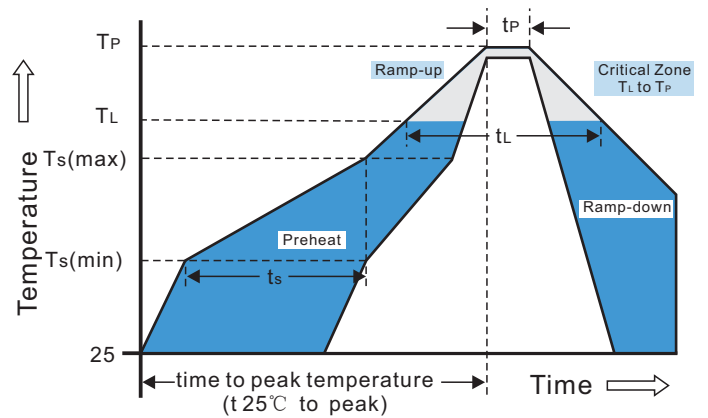

## Marking Code

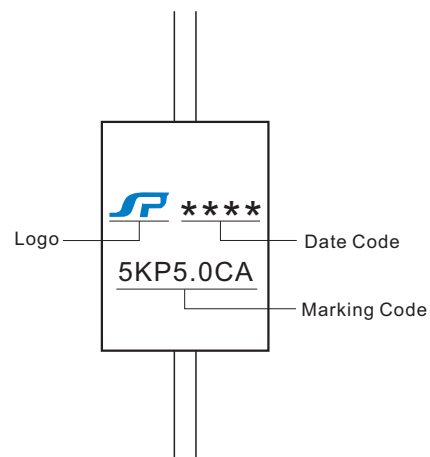
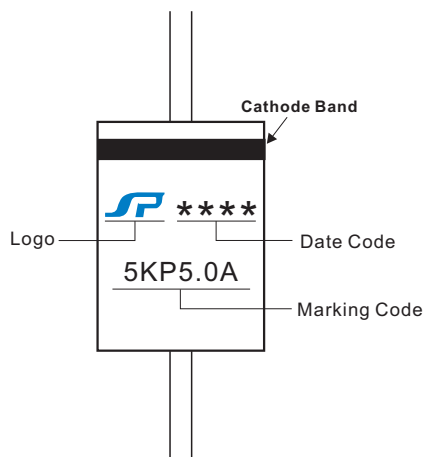

Packaging

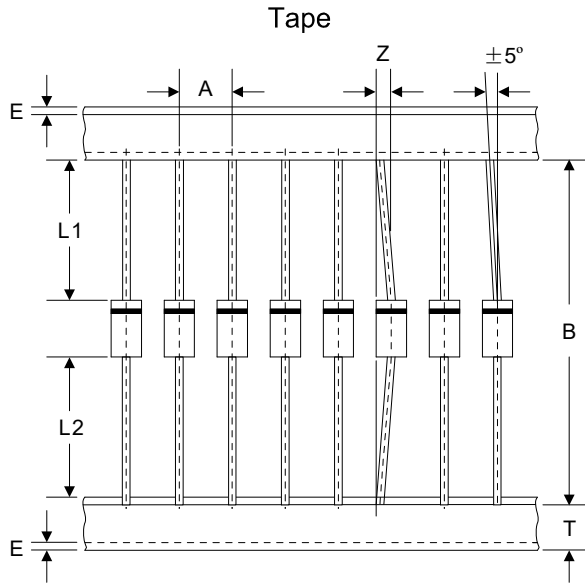

Box

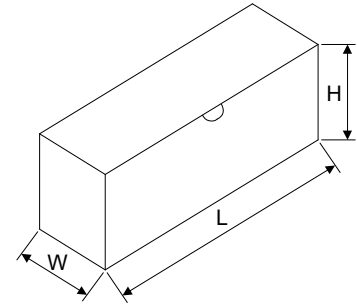

Dimensions in millimeters

A	B	Z	T	E	L1-L2
10.0±0.5	52.0±1.0	1.2Max	6.0±0.4	1.0Max	1.0Max

L	W	H	Quantity
250.0±5.0	78.0±5.0	114.0±5.0	300PCS