



Features

- Precision supply-voltage monitor
 - 4.63V (AMS803/09/10L)
 - 4.26V (AMS803/09/10M)
 - 3.08V (AMS803/09/10T)
 - 2.93V (AMS803/09/10S)
 - 2.63V (AMS803/09/10R)
 - 2.32V (AMS803/09/10Z)
- 140ms(min) reset pulse width
- Push-Pull /RESET Output Configurations for AMS809
- Push-Pull RESET Output Configurations for AMS810
- Open-Drain /RESET output configuration for AMS803
- 12µA Supply Current
- Guaranteed Reset(/Reset) Valid to $V_{CC} = +1.0V$
- Power Supply Transient Immunity
- No External Components

Ordering Information

Part Number	Package
AMS803XTE	Lead free and Green SOT23-3
AMS809XTE	Lead free and Green SOT23-3
AMS810XTE	Lead free and Green SOT23-3

Note: "x" refers to voltage range, see below table.

Suffix: X—Monitored Voltage

X	L	M	T	S	R	Z
Reset Threshold (V)	4.63	4.26	3.08	2.93	2.63	2.32

Block Diagram

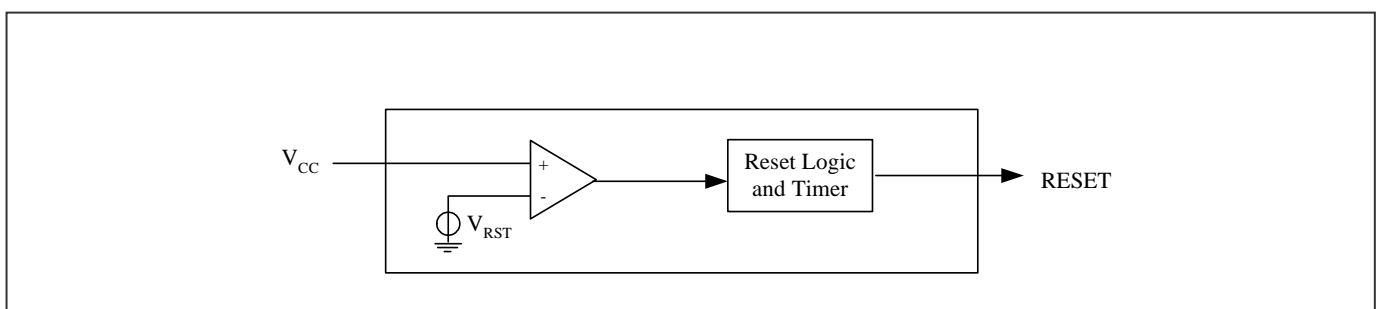

Description

The AMS803/09/10 are microprocessor (μP) supervisory circuits used to monitor the power supplies in μP and digital systems. They provide excellent circuit reliability and low cost by eliminating external components and adjustments when used with +3.3V, +3.0V, or 2.5V powered circuits.

These circuits perform a single function: they assert a reset signal whenever the VCC supply voltage declines below a preset threshold, keeping it asserted for at least 140ms after VCC has risen above the reset threshold. Reset thresholds suitable for operation with a variety of supply voltages are available.

The AMS803 has an open-drain output stage, while the AMS809/10 have push-pull outputs. The AMS803's open-drain /Reset output requires a pull-up resistor that can be connected to a voltage higher than V_{CC} . The AMS803/09 have an active-low /RESET output while the AMS810 has an active-high RESET output. The reset comparator is designed to ignore fast transients on V_{CC} , and the outputs are guaranteed to be in the correct logic state for V_{CC} down to 1V.

Low supply current makes the AMS803/09/10 ideal for use in portable equipment. The ICs are available in 3 pin SOT23 packages.



Pin Configuration

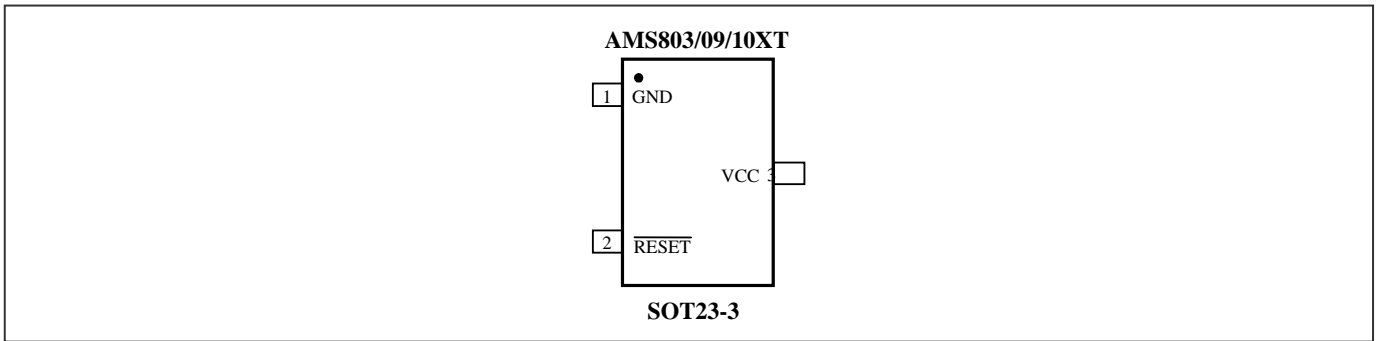

Pin Description

Pin	Type	Description
VCC	-	Supply Voltage. Reset is asserted when V_{CC} drops below the Reset Threshold Voltage (V_{RST}). Reset remains asserted until V_{CC} rises above V_{RST} and keep asserted for the duration of the Reset Timeout Period (t_{RS}) once V_{CC} rises above V_{RST} .
GND	-	Ground
$\overline{\text{RESET}}$	O	Active-Low Reset Output (Push-Pull). It goes low when V_{CC} is below the reset threshold. It remains low for about 200ms after V_{CC} rises above the reset threshold (V_{RST}).

Functional Description

Reset Output

A microprocessor (μP) reset input starts the μP in a known state. Whenever the μP is in an unknown state, it should be held in reset. The supervisory circuits assert reset during power-up and prevent code execution errors during power-down or brownout conditions.

On power-up, once V_{CC} reaches about 1.0V, $\overline{\text{RESET}}$ is a guaranteed logic low of 0.4V or less. As V_{CC} rises, $\overline{\text{RESET}}$ stays low. When V_{CC} rises above the reset threshold, an internal timer releases $\overline{\text{RESET}}$ after about 200ms. $\overline{\text{RESET}}$ pulses low whenever V_{CC} drops below the reset threshold, i.e. brownout condition. If brownout occurs in the middle of a previously initiated reset pulse,

guaranteed to be 0.4V or less until V_{CC} drops below 1.0V. *Reset Timing Diagram* shows the timing relationship.



Typical Application Circuit

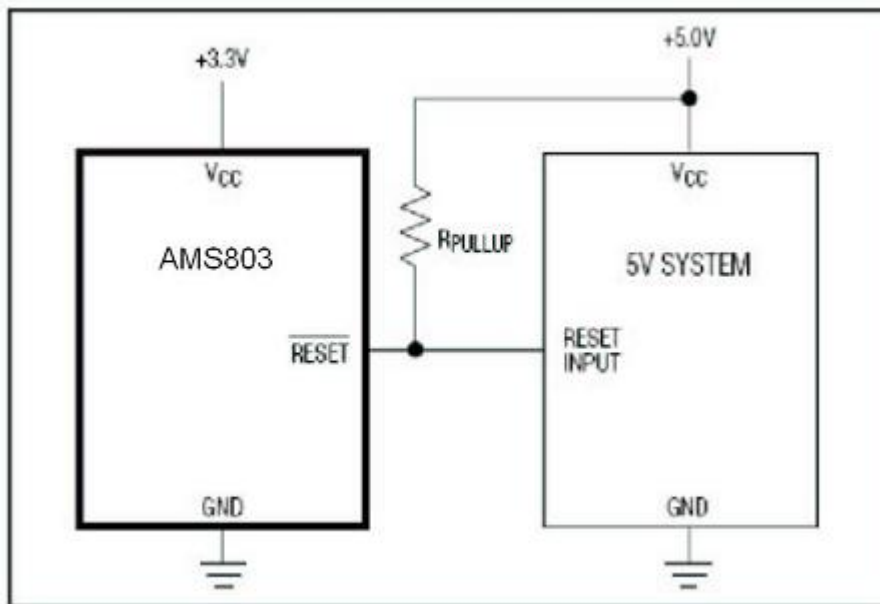
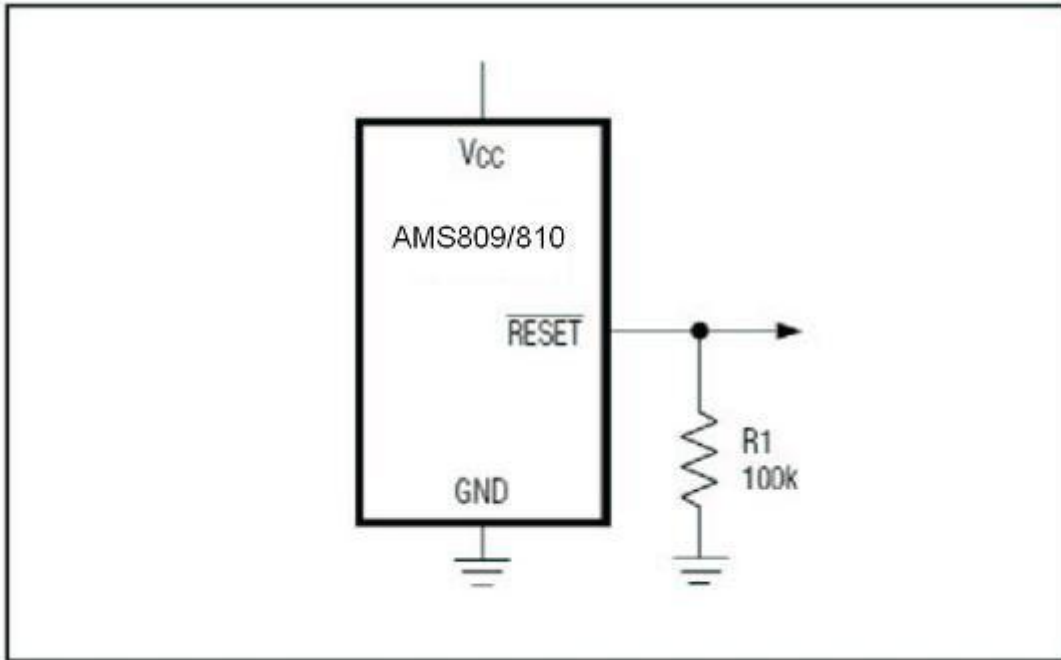



Maximum Ratings

Storage Temperature	-65°C to +150°C
Ambient Temperature with Power Applied.....	-40°C to +85°C
Supply Voltage to Ground Potential (Vcc to GND)	-0.3V to +6.0V
DC Input Voltage (All inputs except Vcc and GND).....	-0.3V to V _{CC} +0.3V
DC Output Current (All outputs)	20mA
Power Dissipation	320mW

Note:

Stresses greater than those listed under MAXIMUM RATINGS may cause permanent damage to the device. This is a stress rating only and functional operation of the device at these or any other conditions above those indicated in the operational sections of this specification is not implied. Exposure to absolute maximum rating conditions for extended periods may affect reliability.

Recommended Operation Conditions

Sym	Description	Test Conditions	Min	Typ	Max	Unit
V _{CC}	Supply Voltage for 803/09/10(L/M)	-	4.5	5.0	5.5	V
	Supply Voltage for 803/09/10(T/S)	-	3.0	3.3	5.5	V
	Supply Voltage for 803/09/10(R/Z)	-	2.7	3.0	5.5	V
T _A	Operating Temperature	-	-40	-	85	



DC Electrical Characteristics

($V_{CC} = V_{RN} + 5\%$ to 5.5V, $T_A = -40 \sim 85^\circ\text{C}$, unless otherwise noted.)(Note 1)

Symbol	Description	Test Conditions		Min	Typ	Max	Unit
V_{CC}	Operating Voltage Range	-		1.0	-	5.5	V
I_{CC}	Supply Current	$V_{CC} < 5.5\text{V}$, AMS8xxL/M		-	10	30	μA
I_{CC}	Supply Current	$V_{CC} < 3.6\text{V}$, AMS8xxR/S/T/Z		-	10	30	
V_{RST} (V_{RTH-})	Threshold Voltage(Falling-edge)(Note 2)	$T_A = 25^\circ\text{C}$	AMS809M	$V_{RN} - 1.1\%$	V_{RN}	$V_{RN} + 1.1\%$	V
			All except 809M	$V_{RN} - 1.5\%$	V_{RN}	$V_{RN} + 1.5\%$	
		$T_A = -40 \sim 85^\circ\text{C}$	AMS809M	$V_{RN} - 1.8\%$	V_{RN}	$V_{RN} + 2\%$	
		$T_A = -40 \sim 85^\circ\text{C}$	All except 809M	$V_{RN} - 2.5\%$	V_{RN}	$V_{RN} + 2.5\%$	
V_{RTH+}	Threshold Voltage(Rising-edge) (Note 2)	$T_A = -40 \sim 85^\circ\text{C}$	AMS809M	4.232	4.31	4.396	
V_{RTH}	Reset Threshold Hysteresis (Note 2)	V_{CC} varies between $V_{RN} \pm 5\%$ (Only for 8xxL/M)		-	50	-	mV
V_{OH}	Output High Voltage	$V_{CC} \geq 4.5\text{V}$ $I_{source} = 800\mu\text{A}$		$V_{CC} - 1.5$	-	-	V
		$V_{CC} \geq 2.7\text{V}$ $I_{source} = 500\mu\text{A}$		$0.8 \times V_{CC}$	-	-	
		$V_{CC} \geq 1.8\text{V}$ $I_{source} = 150\mu\text{A}$		$0.8 \times V_{CC}$	-	-	
		$V_{CC} \geq 1.0\text{V}$ $I_{source} = 4\mu\text{A}$		$0.8 \times V_{CC}$	-	-	
V_{OL}	Output Low Voltage	$V_{CC} \geq 4.5\text{V}$ $I_{sink} = 3.2\text{mA}$		-	-	0.4	V
		$V_{CC} \geq 2.7\text{V}$ $I_{sink} = 1.2\text{mA}$		-	-	0.3	
		$V_{CC} \geq 1.0\text{V}$ $I_{sink} = 100\mu\text{A}$		-	-	0.3	

Note: 1. Parameters of room temperature guaranteed by production test and parameters of full-temperature guaranteed by design.

2. V_{RST} is Reset threshold voltage when V_{CC} falls from high to low level. V_{RN} is nominal reset threshold voltage.

AC Electrical Characteristics

Symbol	Description	Test Conditions		Min	Typ	Max	Unit
t_{RS}	Reset Pulse Width	-	8xxT/S/R/Z	140	240	560	ms
		$T_A = 25^\circ\text{C}$	8xxL/M	140	200	280	

Reset Timing Diagram

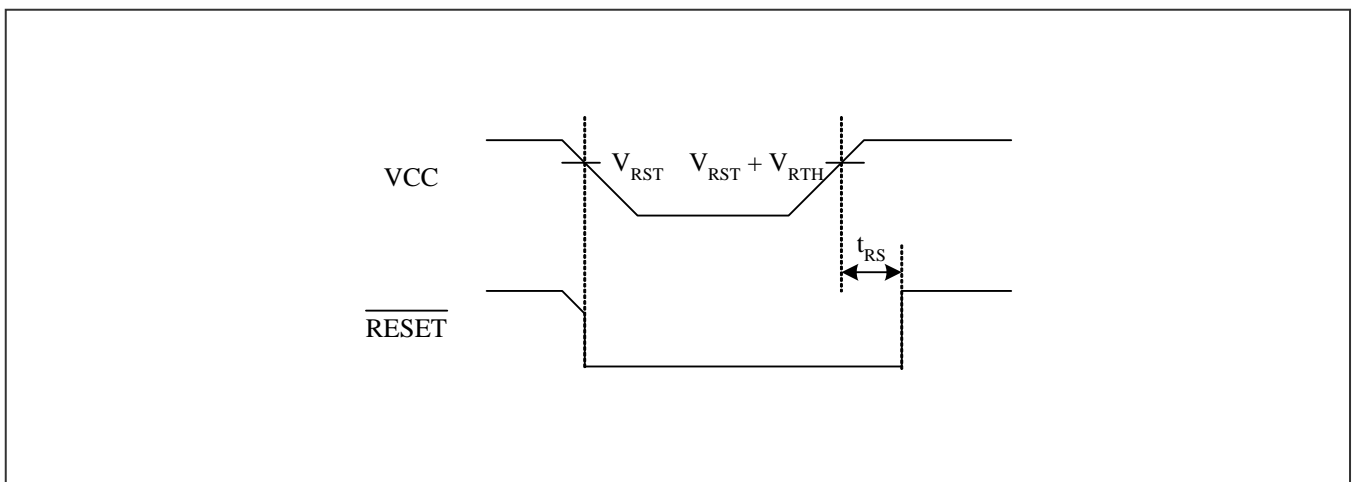



Mechanical Information

TE (Lead free and Green SOT23-3)

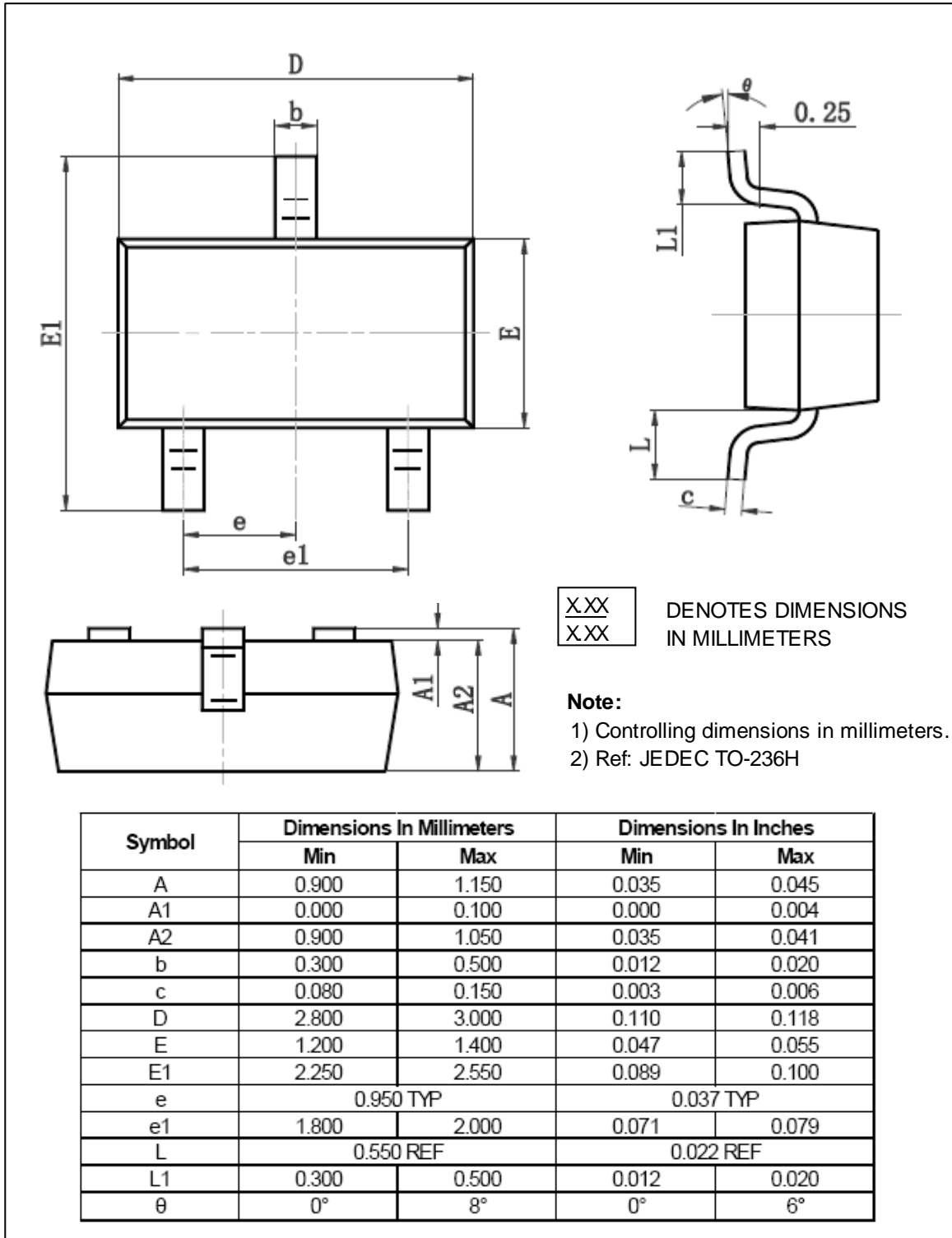



Marking Information

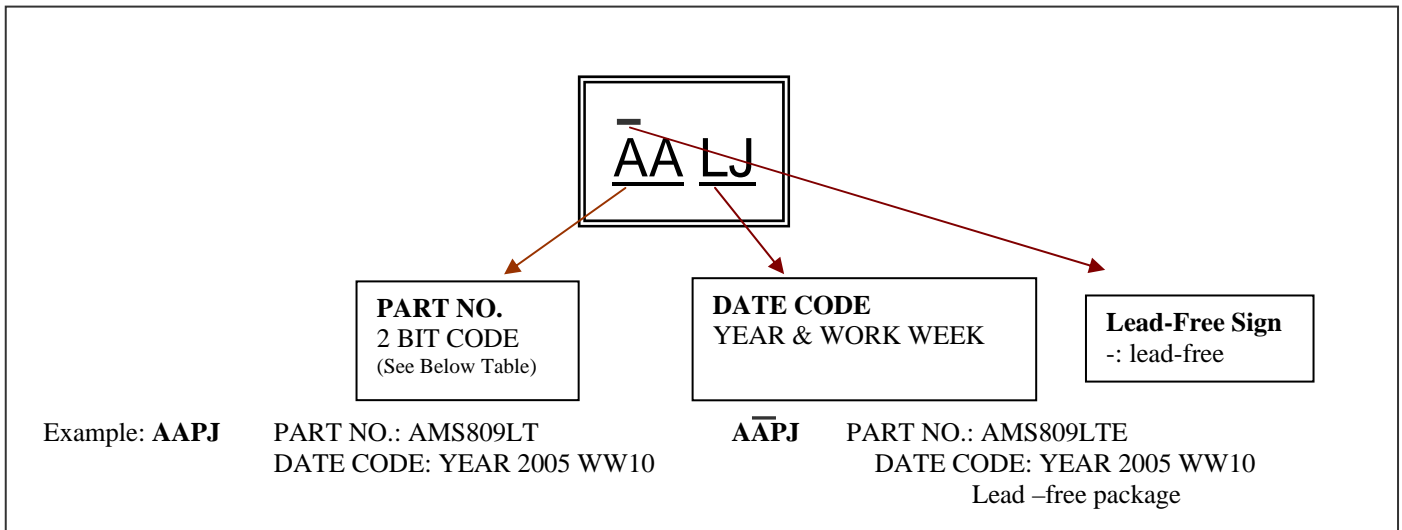

No.	Part No.	Code	No.	Part No.	Code	No.	Part No.	Code
1	AMS809L	AA	7	AMS803L	BC	13	AMS810L	AH
2	AMS809M	AB	8	AMS803M	BD	14	AMS810M	AI
3	AMS809T	AC	9	AMS803T	BE	15	AMS810T	AJ
4	AMS809S	AD	10	AMS803S	BF	16	AMS810S	AK
5	AMS809R	AE	11	AMS803R	BG	17	AMS810R	AL
6	AMS809Z	AF	12	AMS803Z	BH	18	AMS810Z	AM



Notes

Disclaimer:

- AMS reserves the right to make changes to the information herein for the improvement of the design and performance without further notice! Customers should obtain the latest relevant information before placing orders and should verify that such information is complete and current.
- All semiconductor products malfunction or fail with some probability under special conditions. When using AMS products in system design or complete machine manufacturing, it is the responsibility of the buyer to comply with the safety standards strictly and take essential measures to avoid situations in which a malfunction or failure of such AMS products could cause loss of body injury or damage to property.
- AMS will supply the best possible product for customers!