



DONGGUAN NANJING ELECTRONICS LTD.,

TO-92 Plastic-Encapsulate Transistors

2SA1015 TRANSISTOR (PNP)

FEATURES

- Power dissipation

MAXIMUM RATINGS (T_a=25°C unless otherwise noted)

Symbol	Parameter	Value	Unit
V _{CB0}	Collector-Base Voltage	-50	V
V _{CE0}	Collector-Emitter Voltage	-50	V
V _{EBO}	Emitter-Base Voltage	-5	V
I _C	Collector Current -Continuous	-150	mA
P _D	Collector Power Dissipation	400	mW
R _{θJA}	Thermal Resistance from Junction to Ambient	312	°C/W
T _j	Junction Temperature	150	°C
T _{stg}	Storage Temperature	-55~+150	°C

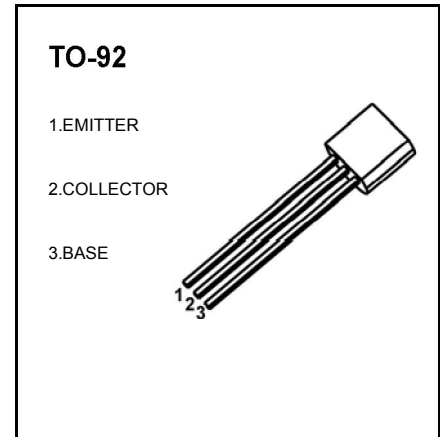

ELECTRICAL CHARACTERISTICS (T_a=25°C unless otherwise specified)

Parameter	Symbol	Test conditions	Min	Typ	Max	Unit
Collector-base breakdown voltage	V _{(BR)CBO}	I _C = -100μA, I _E =0	-50			V
Collector-emitter breakdown voltage	V _{(BR)CEO}	I _C = -0.1mA, I _B =0	-50			V
Emitter-base breakdown voltage	V _{(BR)EBO}	I _E = -100μA, I _C =0	-5			V
Collector cut-off current	I _{CBO}	V _{CB} = -50V, I _E =0			-0.1	μA
Collector cut-off current	I _{CEO}	V _{CE} = -50V, I _B =0			-0.1	μA
Emitter cut-off current	I _{EBO}	V _{EB} = -5V, I _C =0			-0.1	μA
DC current gain	h _{FE}	V _{CE} = -6V, I _C = -2mA	70		400	
Collector-emitter saturation voltage	V _{CE(sat)}	I _C = -100mA, I _B = -10mA			-0.3	V
Base-emitter saturation voltage	V _{BE(sat)}	I _C = -100mA, I _B = -10mA			-1.1	V
Transition frequency	f _T	V _{CE} = -10 V, I _C = -1mA f = 30MHz	80			MHz
Collector output capacitance	C _{ob}	V _{CB} = -10V, I _E =0, f=1MHz			7	pF
Noise figure	NF	V _{CE} = -6 V, I _C = -0.1mA, f = 1kHz, R _G =10kΩ			6	dB

CLASSIFICATION OF h_{FE}

Rank	O	Y	GR
Range	70-140	120-240	200-400

Typical Characteristics

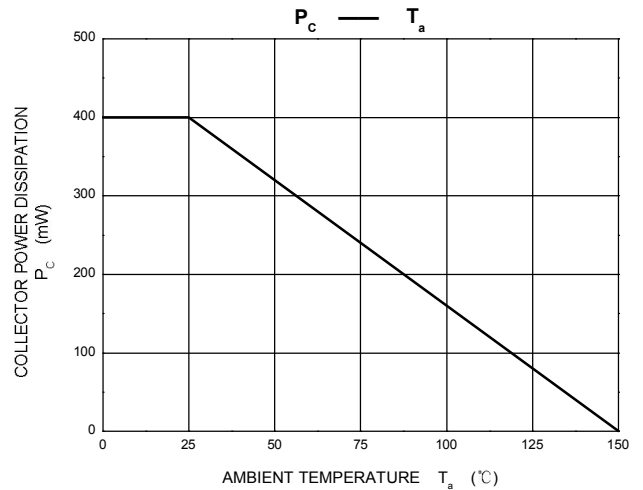
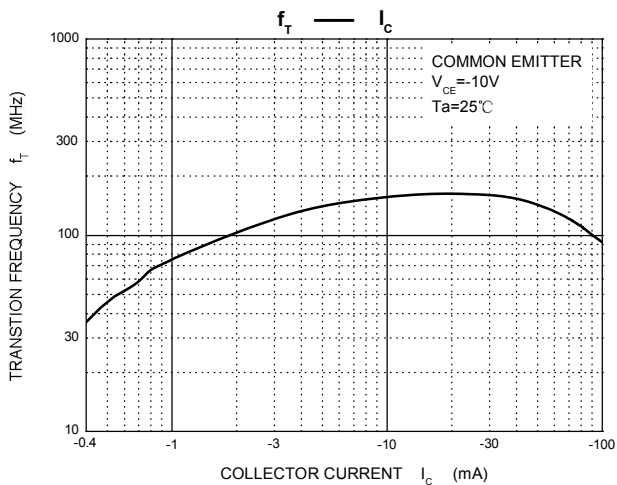
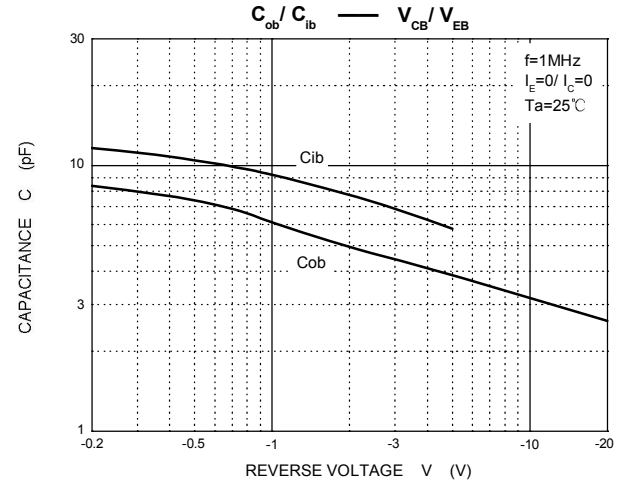
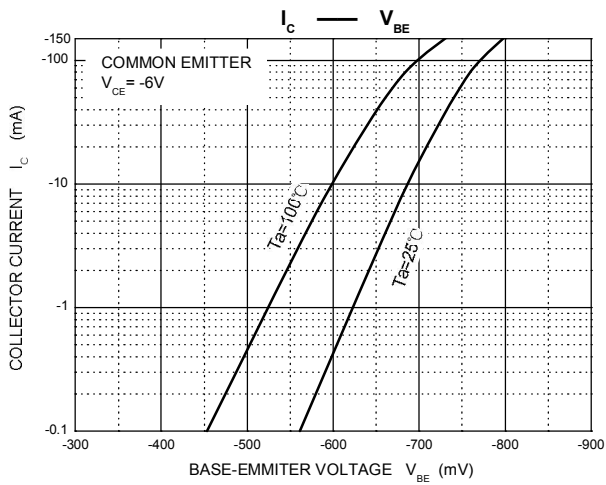
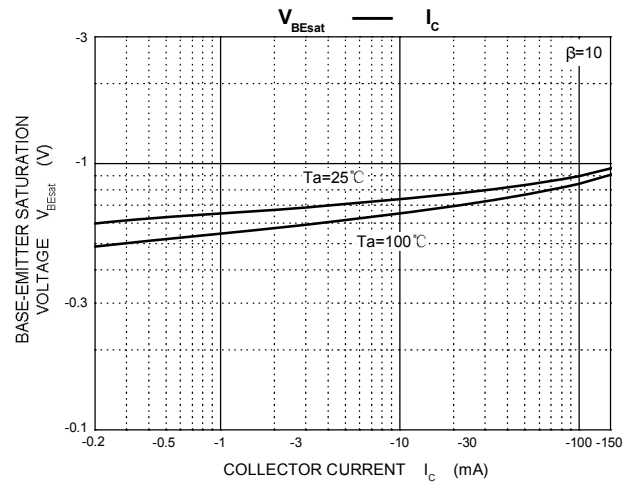
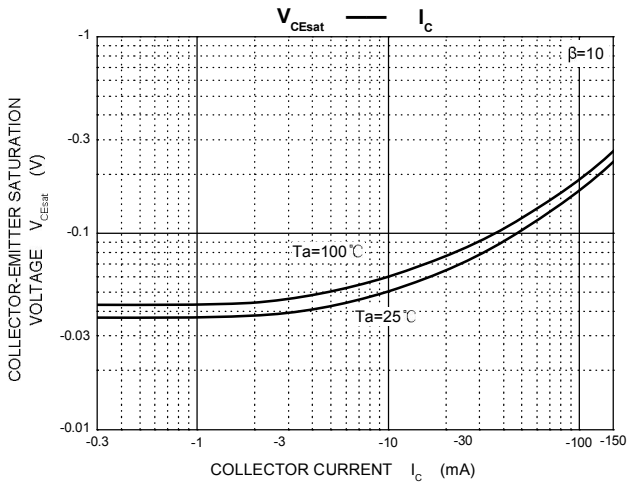
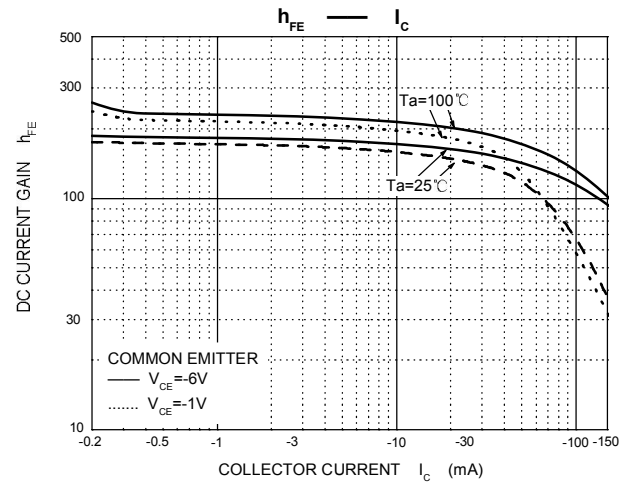
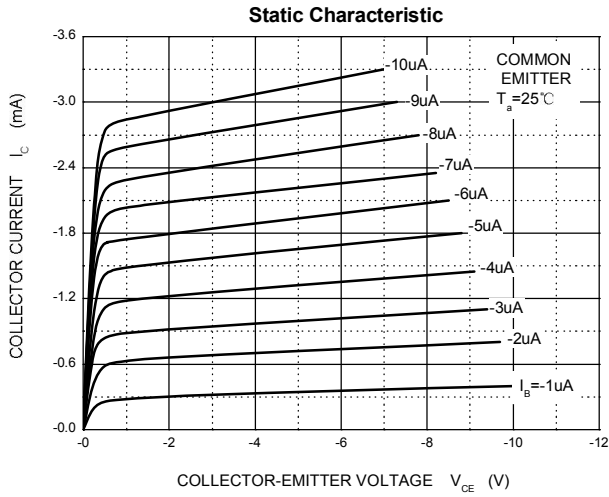

TO-92 Package Outline Dimensions

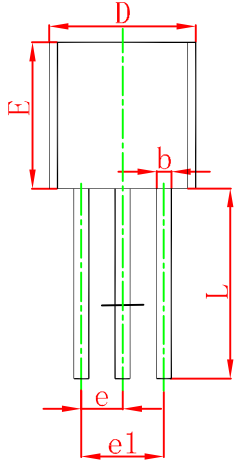
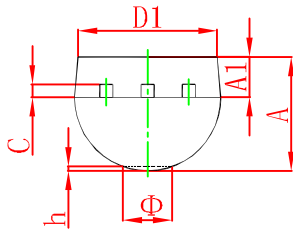

Symbol	Dimensions In Millimeters		Dimensions In Inches	
	Min	Max	Min	Max
A	3.300	3.700	0.130	0.146
A1	1.100	1.400	0.043	0.055
b	0.380	0.550	0.015	0.022
c	0.360	0.510	0.014	0.020
D	4.300	4.700	0.169	0.185
D1	3.430		0.135	
E	4.300	4.700	0.169	0.185
e	1.270 TYP		0.050 TYP	
e1	2.440	2.640	0.096	0.104
L	14.100	14.500	0.555	0.571
Φ		1.600		0.063
h	0.000	0.380	0.000	0.015

TO-92 Suggested Pad Layout

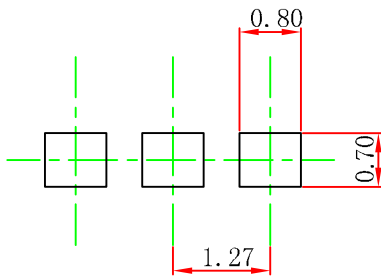

Note:

1. Controlling dimension: in millimeters.
2. General tolerance: ± 0.05 mm.
3. The pad layout is for reference purposes only.