

isc N-Channel MOSFET Transistor

EKI06108

• FEATURES

- With TO-220 packaging
- High speed switching
- Low gate input resistance
- Standard level gate drive
- Easy to use
- 100% avalanche tested
- Minimum Lot-to-Lot variations for robust device performance and reliable operation

• APPLICATIONS

- Power supply
- Switching applications

• ABSOLUTE MAXIMUM RATINGS(T_a=25°C)

SYMBOL	PARAMETER	VALUE	UNIT
V _{DSS}	Drain-Source Voltage	60	V
V _{GSS}	Gate-Source Voltage	±20	V
I _D	Drain Current-Continuous	57	A
I _{DM}	Drain Current-Single Pulsed	114	A
P _D	Total Dissipation	90	W
T _j	Operating Junction Temperature	150	°C
T _{stg}	Storage Temperature	-55~150	°C

• THERMAL CHARACTERISTICS

SYMBOL	PARAMETER	MAX	UNIT
R _{th(ch-c)}	Channel-to-case thermal resistance	1.4	°C/W
R _{th(ch-a)}	Channel-to-ambient thermal resistance	62.5	°C/W

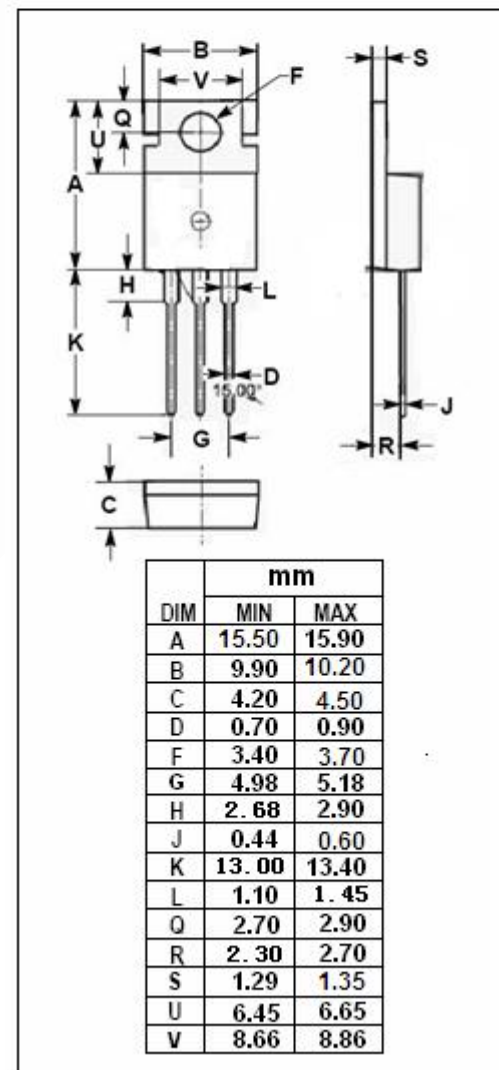
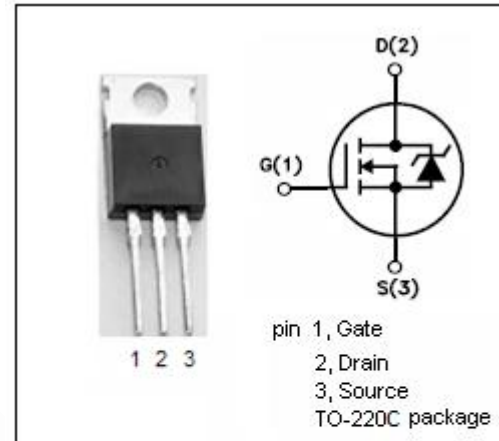

isc N-Channel MOSFET Transistor

EKI06108

ELECTRICAL CHARACTERISTICS

T_C=25°C unless otherwise specified

SYMBOL	PARAMETER	CONDITIONS	MIN	TYP	MAX	UNIT
BV _{DSS}	Drain-Source Breakdown Voltage	V _{GS} =0V; I _D = 0.1mA	60			V
V _{GS(th)}	Gate Threshold Voltage	V _{DS} =V _{GS} ; I _D =0.65mA	1.0		2.5	V
R _{DS(on)}	Drain-Source On-Resistance	V _{GS} = 10V; I _D =28.5A		7.0	9.2	mΩ
I _{GSS}	Gate-Source Leakage Current	V _{GS} =±20V; V _{DS} = 0V			±0.1	μA
I _{DSS}	Drain-Source Leakage Current	V _{DS} = 60V; V _{GS} = 0V			100	μA
V _{SDF}	Diode forward voltage	I _{SD} =28.5A, V _{GS} = 0 V		0.9	1.5	V