



# Echotel® Model 300/301 Ultrasonic Non-Contact Transmitter For Level/ Volume/Open Channel Flow Software version 1.x

## Instruction Manual and Parts List



### DESCRIPTION

The Model 300/301 is a full-featured, powerful ultrasonic system for measurement of liquid level, volume, or open channel flow. Available as an integral or remote mounted transmitter, this extremely versatile system is simple to install and calibrate.

### PRINCIPLE OF OPERATION

The Model 300/301 is a versatile system that utilizes non-contact ultrasonic technology to measure liquid levels in a variety of applications. The system consists of a transmitter and an ultrasonic transducer. The transducer contains a piezoelectric crystal that has the ability to convert electrical signals generated by the transmitter into ultrasonic pulses.

The unit operates by directing ultrasonic pulses, or sound waves, through the air toward the liquid surface. They are then reflected off the liquid surface as an echo, and returned to the transducer. The piezoelectric crystal then converts the returned echo into an electrical signal which is analyzed by the transmitter. The elapsed time between the generation of the ultrasonic pulse and the return echo is proportional to the distance between the face of the transducer and the liquid surface.

**CAUTION:** Please read the entire installation section carefully prior to starting installation.

### TABLE OF CONTENTS

- General Information . . . . .1
- Model Identification . . . . .2
- Measurement Range Calculations . . . . .3-4
- Transducer Mounting . . . . .5-6
- Transmitter Mounting . . . . .6
- Electrostatic Discharge (ESD) Handling Procedure . . . . .6
- Wiring . . . . .7-10
- Software Configuration . . . . .11-23
  - Pre-configuration Worksheet . . . . .12
  - Complete Menu Structure . . . . .13-14
  - Measured Values Menu . . . . .15
  - System Configuration Menus . . . . .15-21
  - I/O Configuration Menu . . . . .22-24
  - Advanced Configuration Menu . . . . .25-26
  - Diagnostics Menu . . . . .26
- Modbus Protocol . . . . .27-32
- Functions and Data Format . . . . .28
- Programming . . . . .28-31
- RS-485 Wiring . . . . .32
- Troubleshooting . . . . .32-33
- Agency Approvals/  
Electrical Specifications . . . . .34
- Dimensional Specifications . . . . .34-35
- Replacement Parts . . . . .35

### UNPACKING

Unpack the instrument carefully, making sure all components have been removed from the packing material. Inspect all components, and report any damage to the carrier within 24 hours. Check the contents of the carton, making sure it agrees with the packing slip and the purchase order. Verify that the model number imprinted on the nameplate matches the number on the packing slip and the purchase order. Report any discrepancies to the factory. Check and record the serial number for future reference when ordering parts.

# MODEL IDENTIFICATION

Each Model 300/301 Ultrasonic Transmitter has a nameplate which shows the model number of the unit. Each model number is coded to identify the options in that specific unit.

Listed below are definitions of each digit of the model number. By referring to these charts, the installer can determine exactly which options the unit contains.

## INTEGRAL MOUNT MODEL 300 TRANSMITTER

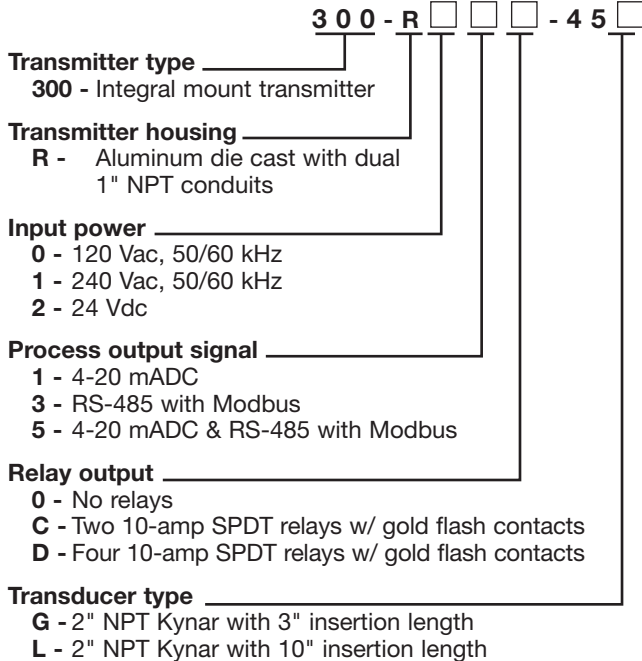

## TRANSDUCER PART NUMBER

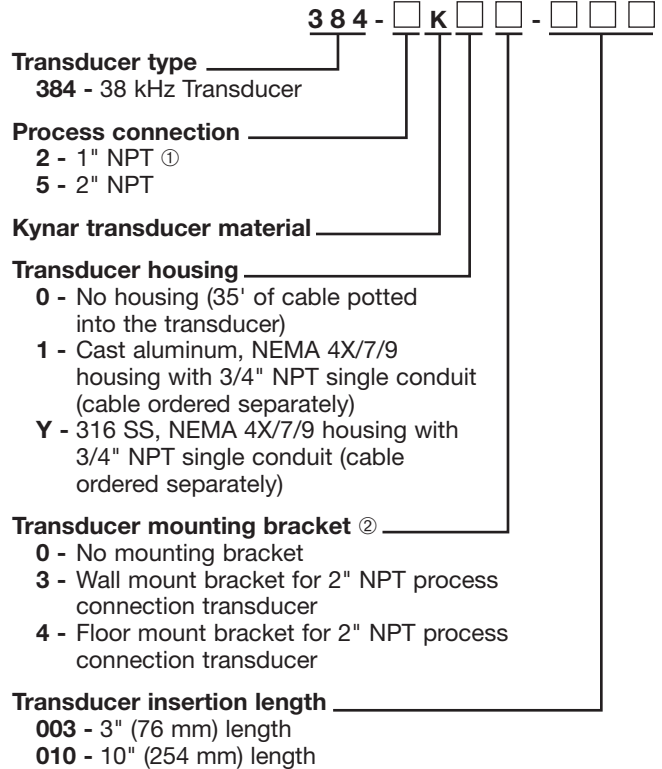

① 1" NPT not available with Transducer housing codes 1 or Y  
② Transducer mounting brackets not available with 1" NPT transducers.

## REMOTE MOUNT MODEL 301 TRANSMITTER

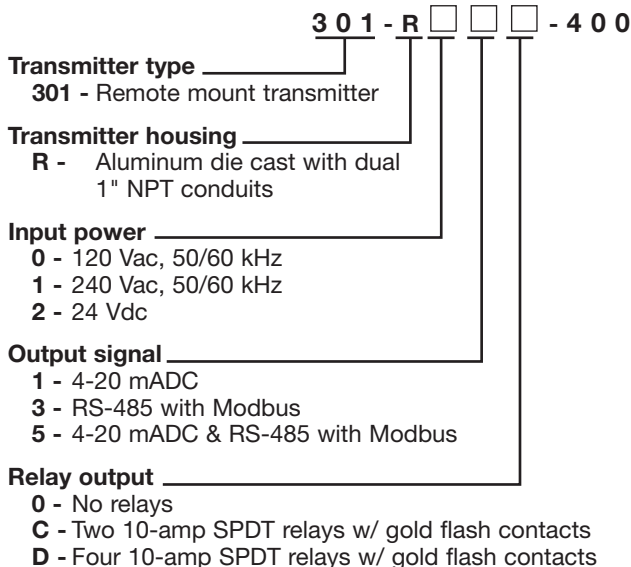

## CONNECTING CABLE PART NUMBER

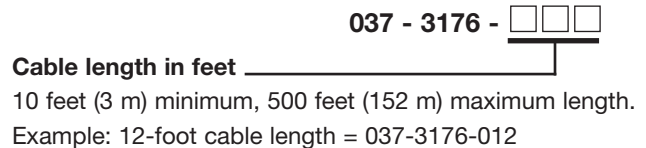

# MEASUREMENT RANGE CALCULATIONS

## MEASUREMENT RANGE PARAMETERS

Ultrasonic non-contact devices are typically rated for a maximum range in ideal conditions. Experience has shown that maximum range must be reduced for certain factors. Although the maximum range rating is somewhat conservative, each application must be evaluated for specific conditions.

The operating parameters listed below can impact the maximum range of measurement:

- Surface agitation
- Vapors and steam (as measured by temperature difference between liquid and air)
- Beam spread interference
- Transducer alignment
- Foam
- Dust
- Air movement
- Ambient temperature
- Pressure

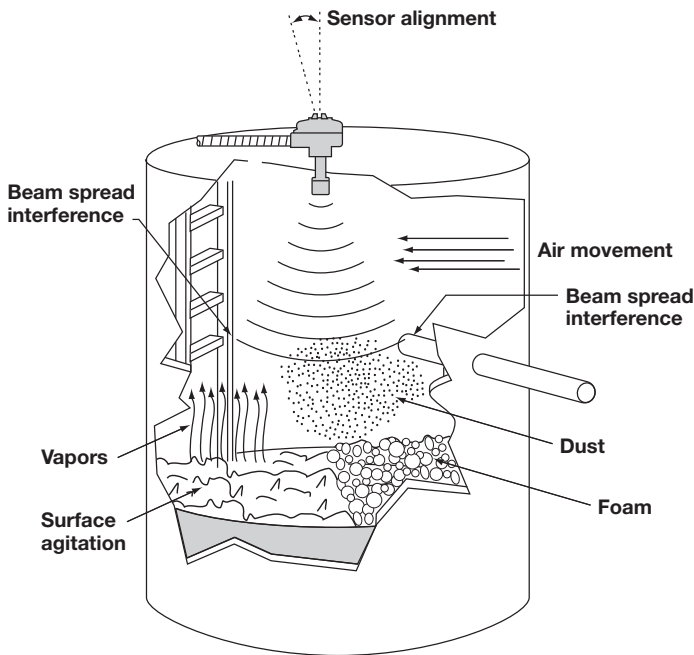

## HOW TO CALCULATE

To estimate how successful a **particular** application may be, using the chart on page 4:

1. Select **one** condition from each of the operating parameters that best describes your application.
2. Enter the corresponding performance multiplier value in the application column.
3. Multiply all of the selected values together.
4. Multiply step 3 by 30' (maximum potential range); this yields a value that is the maximum allowable measurement range for this application.

### Example:

The vessel is a closed-top tank, noninsulated, 22-feet tall.

Surface agitation:	Expect slight agitation from fill line. Performance multiplier 0.9.
Vapor and steam:	The process temperature is +130° F, slight vapor is expected. Performance multiplier 0.9.
Beam interference:	No interference exists. Performance multiplier 1.0.
Transducer alignment:	The transducer will be perpendicular to the liquid surface. Performance multiplier 1.0.
Foam:	None. Performance multiplier 1.0.
Dust:	None. Performance multiplier 1.0.
Air movement:	None. Performance multiplier 1.0.
Ambient temperature:	0 to +120° F. Performance multiplier 1.0.
Pressure:	Atmospheric pressure. Performance multiplier 1.0.

Will the Model 300/301 work for this application?

### Calculation:

Multiply all values in the application column:  
 $0.9 \times 0.9 \times 1.0 \times 1.0 \times 1.0 \times 1.0 \times 1.0 \times 1.0 \times 1.0 \times 30$  feet (maximum) = **24.3 feet**

The calculation yields 24.3 feet as the new maximum range. Since the tank is 22 feet tall, this application will give satisfactory results.

**NOTE:** The performance multipliers provided are conservative estimates. Since these factors are subjective, the values have been designed to provide very high confidence of system success. Contact the factory if there are any questions concerning the interpretation of any of these performance multipliers.

## MEASUREMENT RANGE CALCULATIONS, cont.

Operating Parameter	Condition	Performance Multiplier	Application
<b>SURFACE AGITATION:</b> Surface agitation or waves can degrade the performance. Moderate agitation results in only slight degradation of performance. The worst case is when the surface is a good reflector, but in the wrong direction. (See also transducer alignment.)	Smooth, glasslike surface	1.0	
	Slight agitation, choppiness	0.9	
	Heavy agitation	0.8	
	Slight vortex (6°)	0.7	
<b>VAPORS AND STEAM:</b> Vapors in the air space, above the process, become apparent, and cause problems when the liquid process temperature is well above the temperature of the airspace. The greater the difference, the more expected vapor problems. The problems result from condensation or layering in the sound path, both of which attenuate the sound signal, degrading performance. Avoid steam if possible.  To avoid these problems, ensure that the vessel is insulated so that vapors are less likely to condense. If a vent is used, be sure that the vent, which is where condensation will form, is well away from the transducer.	No condensation	1.0	
	Little condensation	0.9	
	Much condensation/ foggy appearance	0.8	
<b>BEAM SPREAD INTERFERENCE:</b> It is strongly recommended that nothing be allowed within the transducer's beam, except the liquid which is being monitored. Often, the signal from the liquid will be strong, compared to the signal from other sources, such as ladder rungs, filling process material, support struts, etc. For that reason, some applications may provide satisfactory results, even with interference. Interference from agitator blades is only an intermittent interference that usually has little effect on performance.  It is recommended there be no interference within the 6° half angle of the transducer beam. If interference is unavoidable, make the interference as far as possible from the transducer so that the real signal at the longest distance is stronger than the interference signal.	No interference	1.0	
	Agitator at speed less than 60 RPM	1.0	
	Agitator at speed greater than 60 RPM	Consult Factory	
	Interference outside 4°, far from transducer (in bottom third of range)	0.8	
	Interference outside 4°, near to transducer (in top third of range)	0.5	
<b>TRANSDUCER ALIGNMENT:</b> Optimum performance is obtained when the transducer is perfectly aligned. If the process is not perpendicular to the sound beam, the sound will not reflect properly back to the transducer. The effect is significant.	Beam perpendicular to liquid surface	1.0	
	Beam 4° off from perpendicular	0.5	
<b>FOAM:</b> Even small thicknesses of foam can attenuate the ultrasound and render the system inoperative. If possible, moving the transducer to an area in the tank where there is less foam will improve the performance. Thick, heavy-density foams can sometimes produce a reflection from the top of the foam. The multipliers shown at right are general guidelines. For further assistance consult the factory.	No foam	1.0	
	Light froth, less than 0.25" thick	0.8	
	Light foam, less than 0.5" thick	0.5	
	Light foam, more than 1" thick	0.1	
<b>DUST:</b> Dust attenuates the sound and results in poor performance. Even barely perceptible haze in the air can cause significant attenuation.	No dust	1.0	
	Haze, barely perceptible	0.7	
	Slight dust	0.4	
	Heavy dust	0.1	
<b>AIR MOVEMENT:</b> The movement of air, as possible in an open top vessel, can create a layer from which the sound will reflect. This will be most noticeable in applications where vapors or steam tend to form.	No air movement	1.0	
	Open vessel, but transducer below rim	0.8	
	Open air movement in sound path	0.7	
<b>AMBIENT TEMPERATURE:</b> The ambient temperature can have a significant effect on the sound and on the transducer's capability to transmit and receive sound. The most noticeable effect on the transducer is at the temperature extremes.	-20° to +140° F (-29° to +50° C)	1.0	
	-40° to -20° F (-40° to -29° C)	0.9	
	+140° to +160° F (+50 to +70° C)	0.9	
<b>PRESSURE:</b> Sound requires air molecules to be able to travel. Sound will not travel in a vacuum. Likewise, higher pressures will allow the sound to continue without decay, which can cause problems with multiple echoes.	-10 to +50 psig (0.689 to +3.45 Bar)	1.0	
	Pressures outside above rating	Consult Factory	
<b>Multiply all values together in the application column</b>			
<b>Maximum Potential Range for Model 300/301</b>			<b>X 30'</b>
<b>Maximum allowable measurement range for this application</b>			

# TRANSDUCER MOUNTING

**CAUTION:** Please read the entire installation section carefully prior to starting installation. Also read the Measurement Range Calculations section on pages 3-4 to make sure that you have selected the proper level system for your application.

**CAUTION:** If equipment is used in a manner not specified by manufacturer, protection provided by equipment may be impaired.

## GENERAL GUIDELINES

The unit can be provided as an integral mount Model 300 with the transducer connected to the transmitter housing, or as a remote mount Model 301 with the transmitter mounted as far as 500' (152 m) away from the transducer. Both the transducer and the transmitter are approved for Class I, Division 1, Groups B, C, & D areas.

## TRANSDUCER MOUNTING LOCATION

Proper mounting of the ultrasonic transducer is very critical to the operation of any non-contact ultrasonic application. Both the accuracy and the reliability of the Model 300/301 can be adversely affected if the transducer is mounted improperly. This section must be followed carefully to make sure that the optimum mounting location is chosen, and that proper mounting techniques are used for the transducer.

Several factors should be considered when selecting the transducer location:

- Inherent dead band of the transducer
- Standpipes
- Application difficulties (foam, turbulence, vapors)
- Ultrasonic beam angle

## TRANSDUCER DEAD BAND

The transducer must be mounted directly over the liquid surface, as shown in Figure 1. Non-contact ultrasonic instruments require a “dead band” or “blind space” between the face of the transducer and the maximum liquid level. The minimum dead band for the Model 300/301 is 18" (457 mm). This dead band should be taken into consideration when mounting the transducer. If the level must be measured all the way to the top of the tank, the transducer should be mounted in a standpipe as shown in Figures 2 and 3.

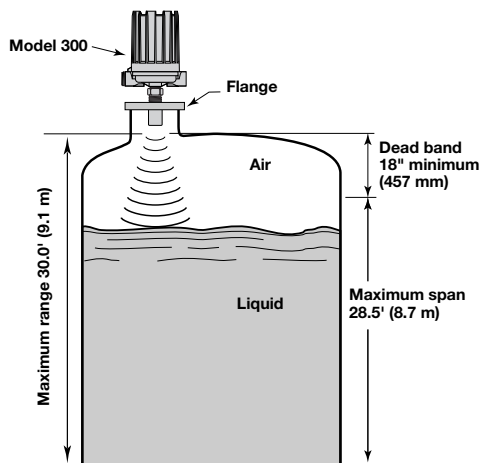

**Figure 1**  
Typical Transducer Mounting

## STANDPIPES

In applications where the material level may come into the dead band, the transducer must be mounted in a standpipe. The diameter of the standpipe should be at least 8" (203 mm); and its length should be limited to 11" (279 mm) from transducer face. Refer to Figure 2.

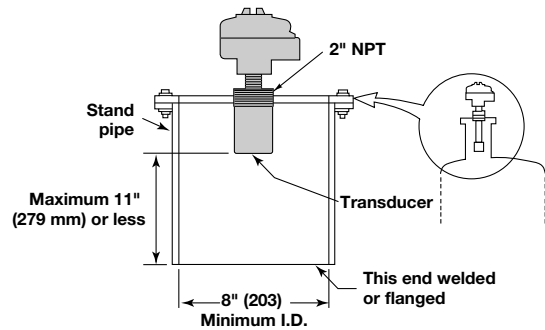

**Figure 2**  
Transducer Mounting in Standpipe

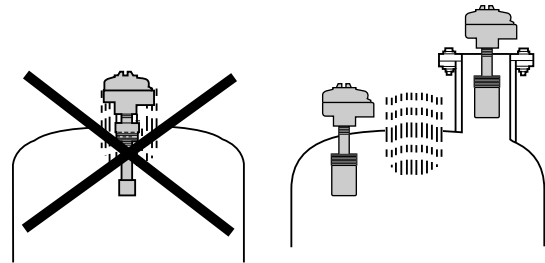

**Figure 3**  
Transducer Mounting for Tanks with Exhaust

## APPLICATION DIFFICULTIES

Typically the liquid surface is most turbulent at the fill point. Foam on the other hand, is most likely to accumulate at the opposite end of the fill. Since foam and turbulence can both create difficulties in reflecting a strong ultrasonic signal back into the transducer, it is best to pick a mounting location away from these areas in the vessel.

Avoid installing the transducer in tank top openings that exhaust heated air or vapors. The boundaries between the vapors and the outside air often represent acoustic impedance gradients that can cause troublesome sound reflections. In those installations, the transducer should be mounted well away from the opening inside the tank, or in a standpipe as illustrated in Figures 2 and 3.

## TRANSDUCER MOUNTING cont.

### ULTRASONIC BEAM ANGLE

The transducer must be mounted such that the beam does not touch the sidewall or obstructions (ladders, fill lines, submerged pumps, etc.) between the transducer face and the liquid surface. The ultrasonic pulse is emitted with a beam spread of 12° (6° radius) from the face of the transducer. Objects that extend into the ultrasonic beam can produce false echoes that may give erroneous level readings.

Table 1 can be used to determine how far away from the wall, ladder, submerged pump, or other obstruction, the transducer must be mounted to avoid producing false echoes. Generally speaking, the transducer should be mounted one foot away for every 10 feet of height.

Distance from Transducer Face (feet)	12° Beam Diameter (feet)	Minimum Distance from Wall or Obstruction (inches)
3'	0.6'	4"
6'	1.3'	8"
9'	1.9'	11"
12'	2.5'	15"
15'	3.2'	19"
18'	3.8'	23"
21'	4.4'	26"
24'	5.0'	30"
27'	5.7'	34"
30'	6.3'	38"

**Table 1**  
**Ultrasonic Beam Angle**

**CAUTION: HAND TIGHTEN ONLY.** Do **NOT** use a pipe wrench or other tools when tightening the transducer. Do **NOT** tighten by holding onto the transducer housing. Avoid excessive twisting of the transducer cable.

**CAUTION:** Do **NOT** install transducers in the center of domed roof tanks. Locate transducers 1' to 3' off-center to minimize false/multiple echoes being reflected off the domed roof.

## TRANSMITTER MOUNTING

**CAUTION:** The instrument is rated per IEC 1010 for use in installation Category II, Pollution Degree 2.

If the unit is supplied as an integral Model 300, please skip to the next section which covers proper ESD handling procedures. This section covers proper transmitter mounting if the unit is a Model 301 remote transmitter.

### TRANSMITTER MOUNTING LOCATION

The following guidelines should be taken into consideration when selecting the mounting location for the remote mounted Model 301 transmitter:

1. Keep the transmitter away from potential sources of electromagnetic noise that may interfere with the performance of the unit.

### TRANSMITTER MOUNTING LOCATION cont.

2. Avoid locations that are exposed to intense direct sunlight. In locations where intense sunlight is a concern, use a sunshade over the unit.
3. Also avoid locations that are subjected to flooding or excessive vibration or shock.

**NOTE:** A switch or circuit breaker shall be installed in close proximity to equipment and within easy reach of operator. It shall be marked as the disconnecting device for the equipment.

## ELECTROSTATIC DISCHARGE (ESD) HANDLING PROCEDURE

Magnetrol electronic instruments are manufactured to the highest quality standards. These instruments utilize electronic components which may be damaged by static electricity present in most work environments. The following steps are recommended to reduce the risk of component failure due to electrostatic discharge:

1. Ship and store circuit boards in anti-static bags. If an anti-static bag is not available, wrap board in aluminum foil. Do not place boards on foam packing materials.
2. Use a grounding wrist strap when installing and removing circuit boards. A grounded workstation is also recommended.
3. Handle printed circuit boards only by the edges. Do not touch components or connector pins.
4. Ensure that all electrical connections are completely made and none are partial or floating. Ground all equipment to a good, earth ground.



# WIRING

**NOTE:** Do NOT attempt to operate this unit at voltages other than as ordered from the Model Identification as it will damage the unit.

**NOTE:** Proper routing of the wires into the 300/301 is critical to unit operation. The power and relay wiring should be brought into the 300/301 through the 1" NPT conduit opening at the back of the unit next to the transformer. All other wiring (transducer, 4-20 mA, and RS-485) should be routed through the 1" NPT conduit opening in the front of the unit. No cables should be routed through the bottom center entry in the base of remote-mounted Model 301 units.

**CAUTION:** This instrument is grounded through green head screw contact in the base. The power input must include a ground wire connected to a good earth ground. Failure to ground the instrument may allow a shock hazard to exist!

## TRANSMITTER POWER WIRING

1. Ensure that power source is turned off from unit.
2. Pull the power supply wires through the conduit connection.
3. Connect the positive (hot) supply wire to the L1 on terminal block TB1.
4. Connect the negative (neutral) supply wire to the L2/N on terminal block TB1.
5. Connect the ground wire to the green screw in the housing base.

	U.S.	Europe	U.K.
Line 1 (H1)	Black	Blue	Brown
Line 2 Neutral	White	Black	Blue
Ground	Green/Yellow	Green/Yellow	Green/Yellow

**Table 2**  
**Wiring Colors By Country/Continent**

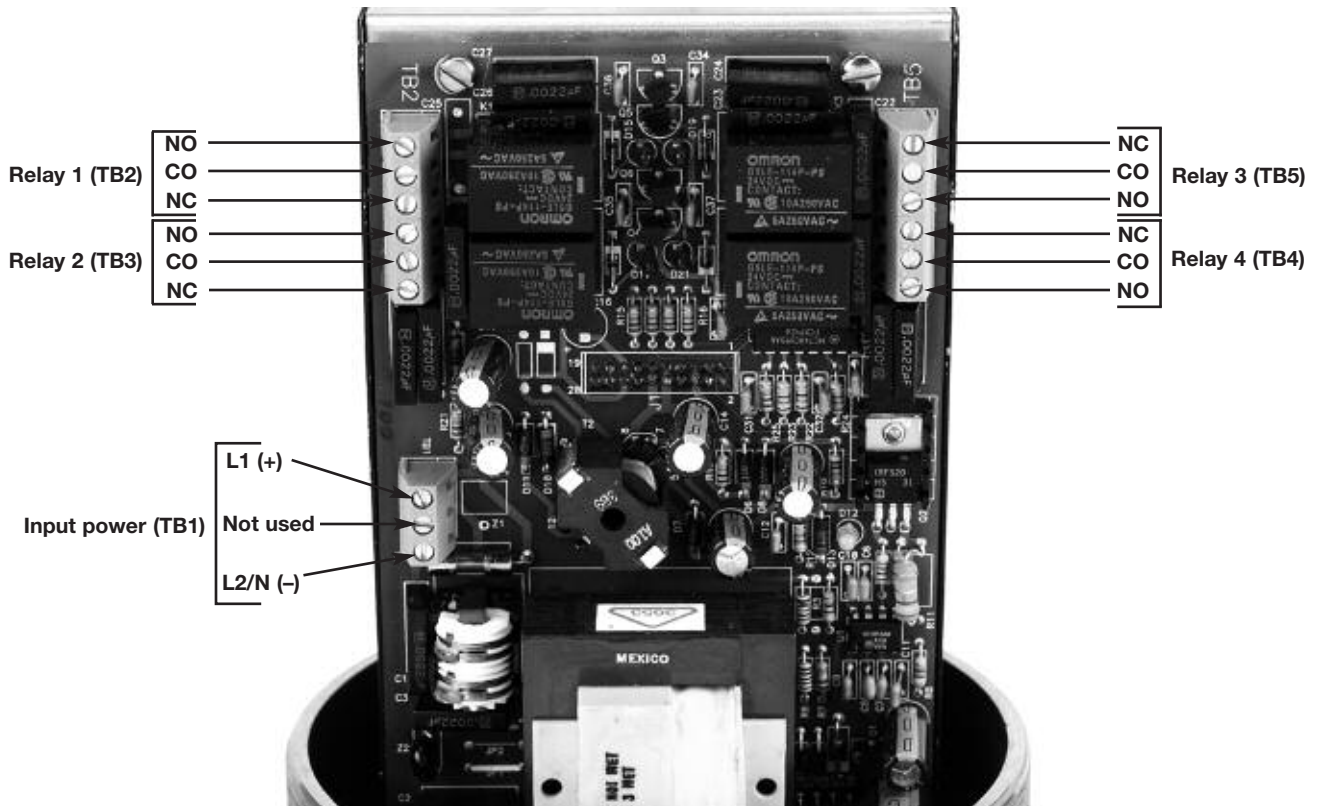

**Figure 4**  
**Power Supply Board Wiring**

## WIRING cont.

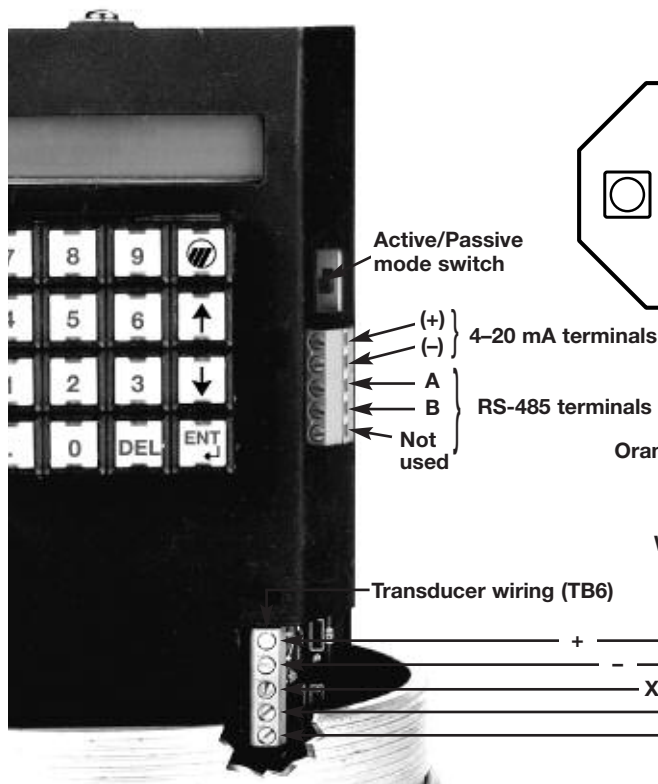

Figure 5  
Front Panel Wiring

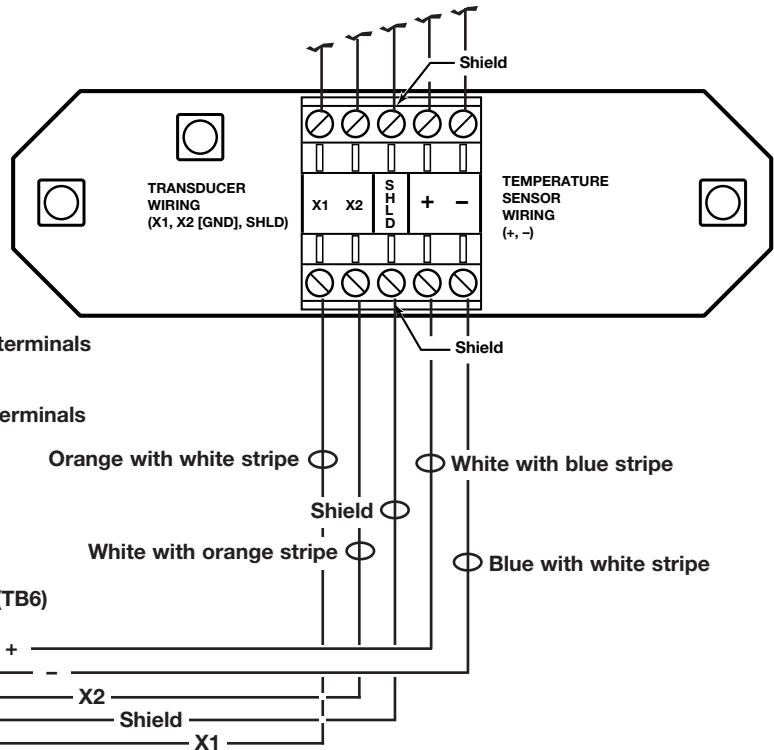

Figure 6  
Optional Remote Transducer Housing Wiring

### TRANSDUCER WIRING

The transducer wiring section describes the proper wiring procedures for connecting a remote Model 301 transmitter with a Model 384 transducer. If you have an integral Model 300 unit, please proceed to Control Relay Wiring.

**NOTE:** Remote mount Model 301 transducer cabling should be routed through the 1" NPT conduit opening in the front of the unit. No cables should be routed through the bottom center entry in the base of remote-mounted Model 301 units.

The transducer cable consists of two twisted pairs of wire, wrapped with a shield. Each wire is labeled for identification. Refer to Figures 5 and 6.

After running the transducer wiring through the conduit, from the transducer to the transmitter, separate the wires into two groups;

- Group 1** – Signal Wiring (transducer), orange wire pair.
- Group 2** – Temperature Compensation Wiring (temperature sensor), blue wire pair.

**NOTE:** It is imperative that Magnetrol cable, part number 037-3176 (Belden Type 8102 or Carol C0515/E111240), be used. If connecting cable was not provided with unit, consult the factory for specifications. Maximum total cable length is 500 feet (152 m). AVOID SPLICING CABLE.

To prevent electromagnetic noise from disrupting the normal operation of the Model 301, each transducer cable must be run in its own conduit, separated from power, relays, and other transducer cables.



## WIRING cont.

### WITHOUT A TRANSDUCER HOUSING

#### Group 1

1. Connect the orange with white stripe wire to the terminal marked **X1** at TB6.
2. Connect the shield wire to the terminal marked GND at TB6.
3. Connect the white with orange stripe wire to the terminal marked **X2** at TB6.

#### Group 2

1. Connect the white with blue stripe wire of the twisted pair to terminal labeled positive (+) at TB6.
2. Connect the blue with white stripe wire of the twisted pair to terminal labeled negative (-) at TB6.
3. Proceed to the appropriate section for wiring options.

**NOTE:** Both groups of wire must be connected.

### WITH A TRANSDUCER HOUSING

If transducer housing is provided, use the connecting cable ordered with the remote transducer housing. Connect the transducer cable between the terminal block in the transducer housing to TB6 in the transmitter. Be sure to connect wires to appropriate terminals. Refer to Figures 5 and 6 on page 8.

#### Group 1

1. Connect the orange with white stripe wire from the transducer housing terminal marked **X1** to the terminal marked **X1** at TB6 in the transmitter.
2. Connect the shield from the transducer housing terminal marked **SHLD** to the  $\overline{\text{GND}}$  terminal at TB6 in the transmitter.
3. Connect the white with orange stripe wire from the transducer housing terminal marked **X2** to the terminal marked **X2** at TB6 in the transmitter.

#### Group 2

1. Connect the white with blue stripe wire of the twisted pair from the transducer housing terminal marked positive (+) to the terminal labeled positive (+) at TB6.
2. Connect the blue with white stripe wire of the twisted pair from the transducer housing terminal marked negative (-) to the terminal labeled negative (-) at TB6.
3. Proceed to the appropriate section for wiring options.

**NOTE:** In high humidity applications, it is recommended that the wiring within the remote transducer housing be completely immersed in an insulating compound (3M #4441 Gella Re-enterable Encapsulating Compound or equivalent).

### CONTROL RELAY WIRING

The Model 300/301 unit is supplied with four relays that can operate as normal, independent contact closures or be used as dedicated relays as follows:

- Relay 1 Normal/Fault/Lead-Lag
- Relay 2 Normal/Lead-Lag
- Relay 3 Normal/Lead-Lag
- Relay 4 Normal/Lead-Lag

Relay connections are supplied on the main terminal board. Refer to Figure 4 on page 7.

1. Connect two-wire leads to the desired relay connection for relays 1–4. Connect one wire to the terminal labeled COM and the other to the terminal for the desired contact function, NC for normally closed or NO for normally open. Repeat this step for each relay.
2. Refer to Relay Settings in the I/O Configuration section on page 22 for information on configuring the relays.
3. Proceed to wire any remaining options the unit may have.

**NOTE:** If the device to be operated by the relay has an inductive load, a separate power supply should be used for the Model 300/301 transmitter.

### OUTPUT SIGNAL WIRING

#### 4–20 mA DC Output

A shielded twisted pair should be used for the 4–20 mA output. The + and – connections are made at the terminal block to the right of the 16-button keypad as shown in Figure 5 on page 8. The shield is connected with a female disconnect to a connector located in the housing base, just below the sensor connections. The loop is optically isolated, has non-grounded outputs, and can drive a 1000  $\Omega$  load.

**NOTE:** The output may be either an active or passive 4–20 mA. If passive mode, customer must provide loop power. Figure 5 on page 8 shows the Active/Passive mode switch.

1. Cut approximately 8" of insulation off the twisted shielded cable.
2. Cut the shield wire down just short enough to crimp a female disconnect (Sta-Kon<sup>®</sup>) connector. Crimp the connector on and push this over the male connector located at the base of the housing as shown in Figure 7.
3. The + and – wires should then be twisted together and run up to the 4–20 mA terminal block located to the right of the 16-button keypad as shown in Figure 7.
4. Connect the positive (+) shielded twisted pair wire to the + location on the terminal block.
5. Connect the negative (–) shielded twisted pair wire to the – location on the terminal block.

**NOTE:** The shield should be connected to an earth ground at only one location.

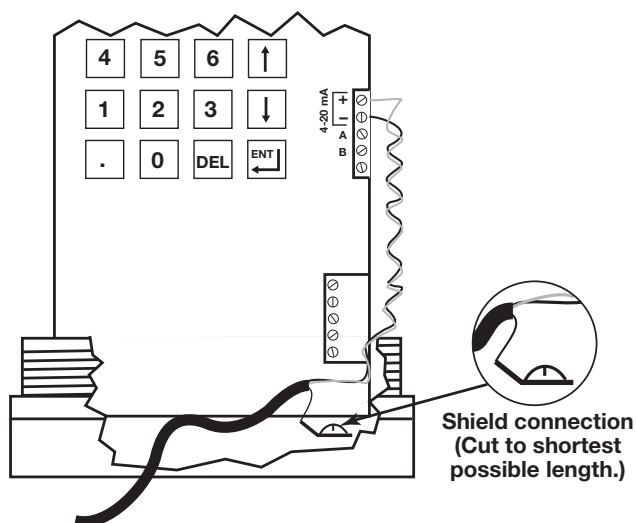

Figure 7  
4–20 mA Wiring

## WIRING cont.

### OUTPUT SIGNAL WIRING cont.

#### RS-485 Output

A shielded twisted pair should be used for the RS-485 wiring. The “A” and “B” connections are made at the terminal block to the right of the 16-button keypad as shown in Figure 5 on page 8. The shield is connected with a female disconnect to a connector located in the housing base, just below the sensor connections.

1. Cut approximately 8" of insulation off the twisted shielded cable.
2. Cut the shield wire down just short enough to crimp a female disconnect (Sta-Kon®) connector. Crimp the connector on and push this over the male connector located at the base of the housing as shown in Figure 7.

**NOTE:** If both the 4-20 mA and the RS-485 outputs are being used, twist the shields together and follow Step 2 above.

3. The “A” and “B” wires should then be twisted together and run up to the RS-485 terminal block located to the right of the 16-button keypad as shown in Figure 7.
4. Connect the “A” wire from the control room converter to the terminal marked “A” on the RS-485 terminal block located to the right of the 16-button keypad as shown in Figure 5.

5. Connect the “B” wire from the control room converter to the terminal marked “B” on the RS-485 terminal block located to the right of the 16-button keypad as shown in Figure 5.

6. If connecting multiple Model 300/301 units in a daisy-chain configuration, be sure to connect the wiring in parallel and have the ending unit with the termination resistor jumpered. Jumpers should be removed from other units in the daisy chain. The three termination jumper pins (JP1) are located behind the black protective cover and just below the RS-485 terminal block. The last unit in the daisy chain should have a jumper between pins 1 and 2. All other units in the daisy chain should either have a jumper between pins 2 and 3, or have no jumper at all.

**NOTE:** Polarity among units in loop must be observed.

**NOTE:** If connecting several units, note the color wire used for A and B and ensure that the same designated color is used for each of the units.

# SOFTWARE CONFIGURATION

## GENERAL CONFIGURATION INSTRUCTIONS

The Model 300/301 ultrasonic non-contact transmitter contains a microprocessor-based operator interface which allows for easy configuration of level, flow, or volume control applications. All calibration parameters for these applications are entered via a keypad located on the front of the transmitter.

The primary structure of the software is broken down into six main menu groups as follows:

<b>Measured Values</b>	To view measured values
<b>System Config</b>	First time configuration (Essential programming data)
<b>I/O Config</b>	Configure all input/output functions
<b>Advanced Config</b>	Additional values that affect the performance of the unit
<b>Diagnostics</b>	Test functions and unit performance data
<b>Run mode</b>	Normal display. The unit will default to this display after approximately five minutes without any key stroke.

**CAUTION:** The Model 300/301 is shipped from the factory with the password **300**. If the password is misplaced or forgotten, please consult the factory for assistance.







## PASSWORD

A password protection system restricts access to portions of the menu which affect the unit's operation and configuration. The password will be requested whenever programming changes are requested in a menu. Once the password is entered in a specific menu, it is not requested again until you exit that menu and go into a different menu to make changes.

The password can be changed to any number between 1 and 32767. This procedure is described under the **ADV CONFIG** menu on page 25.



## OPERATOR KEYPAD



All unit configuration instructions in this manual will appear on the instrument display. The following keys are used:

-  UP arrow: Scroll to the previous menu item.
-  DOWN arrow: Scroll to the next menu item.
-  ENTER: Enter the next menu level or confirm information of the current menu item.
-  DELETE: To exit or back out of the current menu level, or delete an entry.
-  Numeric input of data.
-  Decimal point.
-  For entering tag line data (see page 26).

## KEY FUNCTIONS FOR ENTERING INPUT

**NOTE:** When a line ends with an up or down arrow, that line may be scrolled up or down.

When the symbol  is displayed on the top line, push **ENT** to program this selection, or press  to proceed to the next selection.

When the symbol  is displayed on the bottom line, push  to change the selection; then push **ENT** to accept.

When the symbol  is displayed on the bottom line, enter the value, then push **ENT** to accept.

**NOTE:** Pressing **DEL** will back you out of the configuration menu and return you to run mode.

**NOTE:** If a key is not pressed for 5 minutes, the display returns to the run mode.

# MODEL 300/301 PRE-CONFIGURATION WORKSHEET

This page is designed to be a worksheet where all the system configuration data can be written down prior to entering them into the unit. The system configuration is much faster once all the data is known. This page can then be used for future reference after the unit has been configured.

System configuration of the Model 300/301 is easily accomplished by inputting the following values as they relate to your specific application:

Level Applications	Volume & Level Applications	Flow & Level Applications
Level units:	Level units:	Level units:
Range:	Volume units:	Flow units:
Span:	Vessel type:	Primary flow element:
	Vessel dimension:	Reference distance:
	Range:	Maximum head:
	Span:	Low flow cutoff:

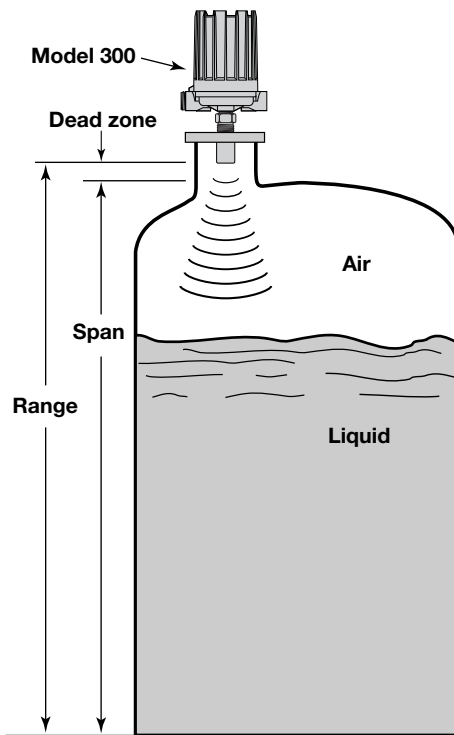

**Units:** A selection for level units is required regardless of whether level will be the primary measurement. This is because the Model 300/301 calculates volume and flow from the level that is measured in the vessel, flume, or weir. One of the four level units shown on page 13 must be selected. Volume or flow units must also be selected if the Level Only mode is not being used.

**Range:** Range is defined as the distance from the face of the ultrasonic transducer to the bottom of the level span. This usually is the distance from the face of the transducer to the bottom of the vessel. The maximum range for the Model 300/301 is 30' (9.1m).

**Span:** Span is the distance from the bottom of the level measurement to the top. The maximum span is the range minus the dead band (18") of the ultrasonic transducer. The maximum span for the 300/301 is 28.5' (8.7m).

**Vessel Type:** The Volume & Level mode will require one of the nine vessel types shown on page 13 to be selected. Equations to calculate volume from level are stored in the software. If the application has a vessel type that is not listed, then a custom table will need to be built using either a linear or spline curve.

**Vessel Dimensions:** Dimensional data will vary depending on which vessel type is selected. See pages 18 & 19 for more information.

**Primary Flow Element:** The Flow & Level mode will require selection of one of the many flow elements to be selected that are shown on page 14. Equations to calculate flow from level are stored in the software. If the application has a flow element that is not listed, then a custom table will need to be built using either a linear or spline curve.

**Reference Distance:** The reference distance is the open channel flow equivalent to the range. See above.

**Maximum Head:** Maximum head is the open channel flow equivalent to the span. See above.

**Low Flow Cutoff:** The low flow cutoff will force a zero flow value when the level is at or below this point.

# SOFTWARE CONFIGURATION cont.

## GENERAL PROGRAMMING MENUS

Following is an outline of the general menu structure used in the Model 300. Even though all features are shown, certain features will only affect specific models. For example, the relay menu can be accessed in all models, but changes will only affect the models with relays.

Use the UP and DOWN arrow keys to scroll through any portion of the menu; use the ENT key to make a selection. A detailed description of each portion of the menu follows on page 15.

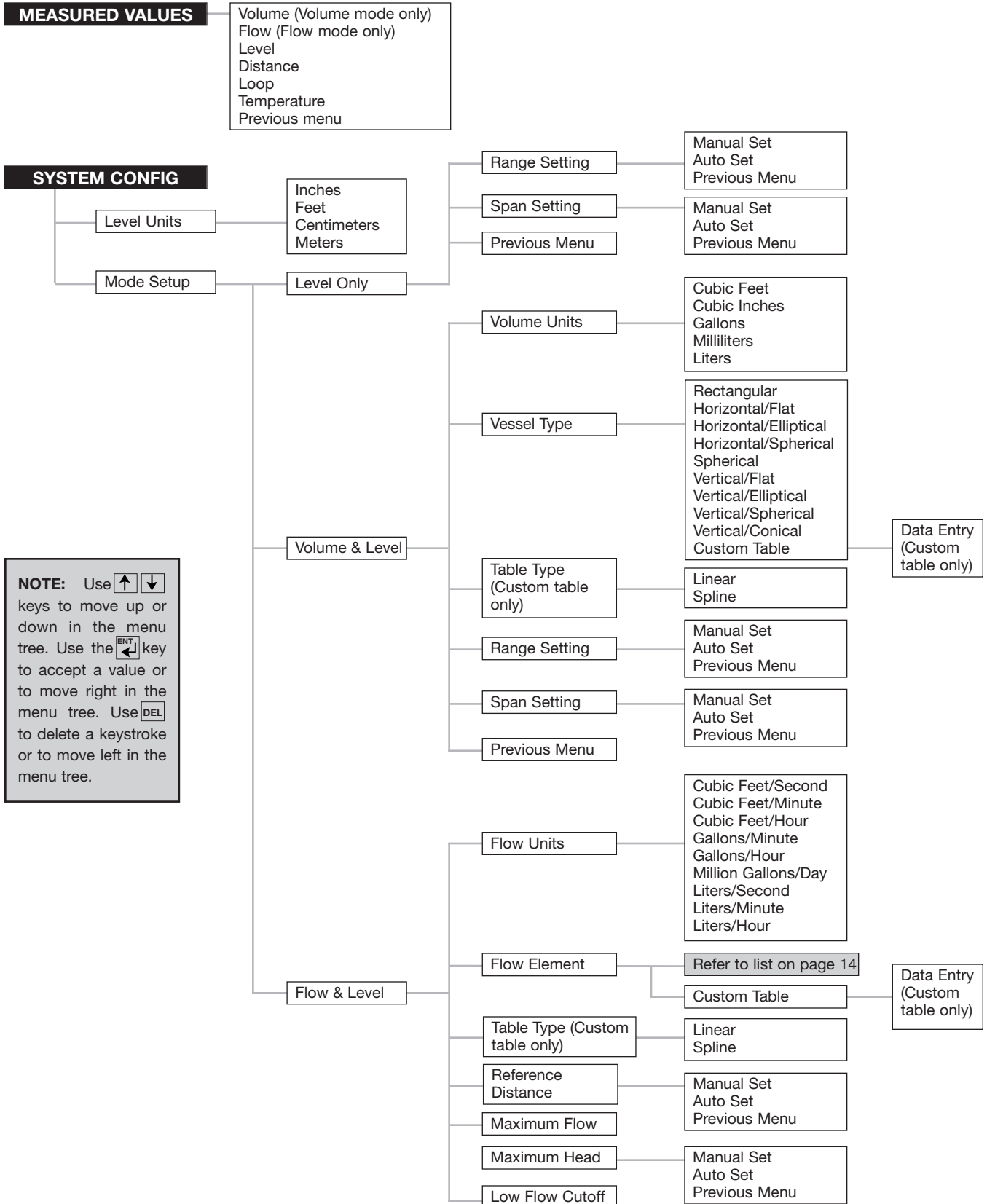

**NOTE:** Use keys to move up or down in the menu tree. Use the key to accept a value or to move right in the menu tree. Use to delete a keystroke or to move left in the menu tree.

# SOFTWARE CONFIGURATION cont.

## GENERAL PROGRAMMING MENUS cont.

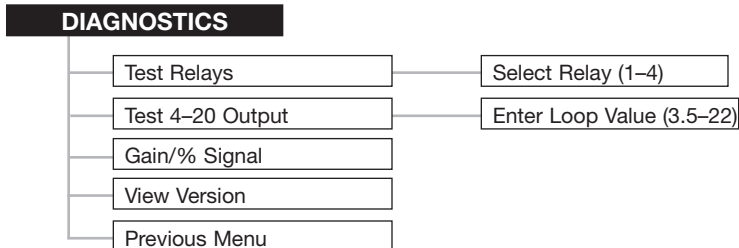
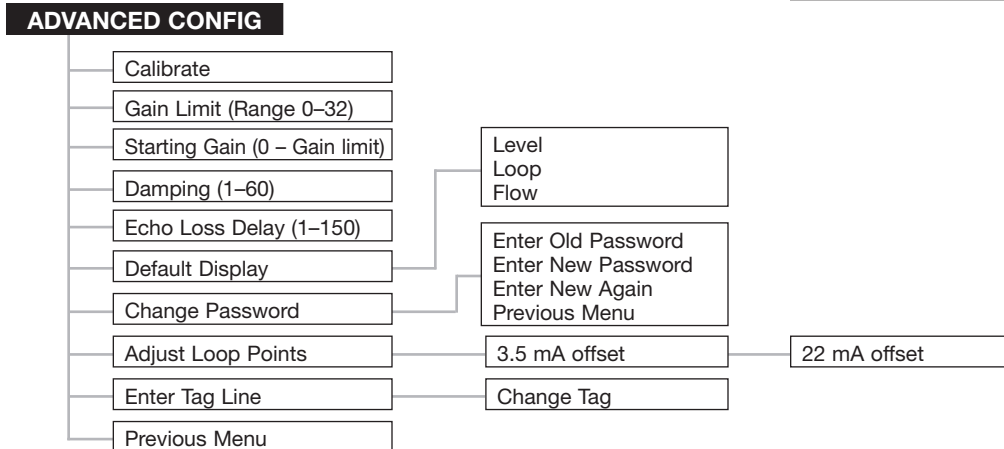
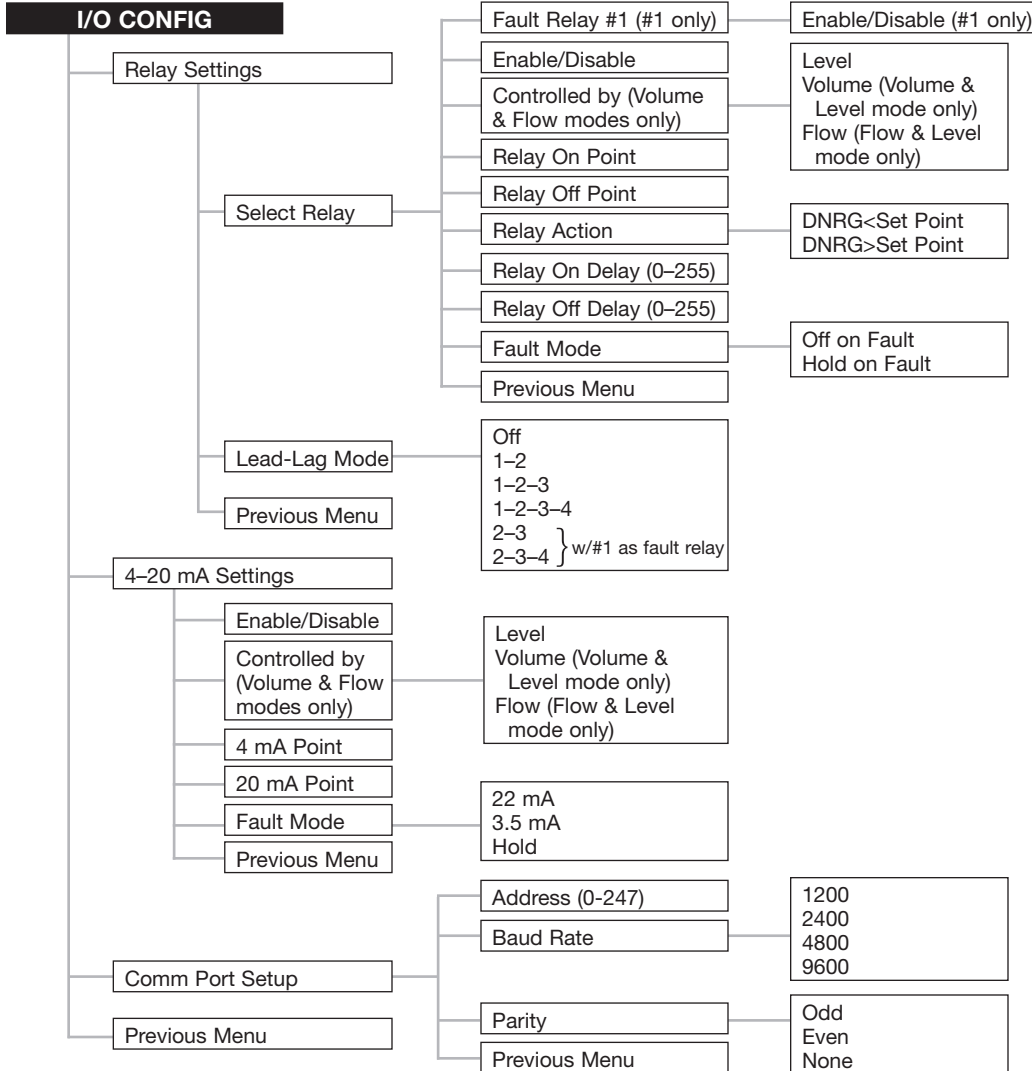

From page 13

### Flow Element (flow mode only)

Palmer Bowlus

- 4"
- 6"
- 8"
- 10"
- 12"
- 15"
- 18"
- 21"
- 24"
- 27"
- 30"

H-Flume

- 6"
- 9"
- 12"
- 18"
- 24"
- 30"
- 36"
- 54"

V-notch

- 22.5°
- 30°
- 45°
- 60°
- 90°
- 120°

Parshall

- 1"
- 2"
- 3"
- 6"
- 9"
- 12"
- 18"
- 24"
- 36"
- 48"
- 60"
- 72"
- 96"
- 120"
- 144"

Rectangular w/End Contractions

Rectangular w/o End Contractions

Cipoletti

Manning

Custom Table



## SOFTWARE CONFIGURATION cont.

### MEASURED VALUES MENU

The Measured Values Menu can be accessed by pressing the **ENT** key from the run mode. You may scroll through the measured values by using the up and down arrows. The items displayed in the Measured Values Menu will differ

depending on whether **Level Only**, **Vol & Level**, or **Flow & Level** has been selected in the System Config section described later in this manual.

Measured Values Menu		
Display	Keystroke	Comments or Additional Keystrokes
Magnetrol Int'l xxxx units	Press <b>ENT</b>	Enters the Measured Values Menu.
Measured Values	Press <b>ENT</b>	Displays the first item (Level) in the Measured Values Menu.
Level xxxx units	Press ↓	Indicates the level of material in the vessel. Pressing ↓ allows you to continue to the next menu item.
Distance xxxx units	Press ↓	Indicates the distance from the face of the transducer to the target. Pressing ↓ allows you to continue to the next menu item.
Loop xxxx	Press ↓	Indicates the milliamp current loop output. Pressing ↓ allows you to continue to the next menu item.
Temperature xxxx F	Press ↓	Indicates the air temperature at the transducer. The temperature units are in ° F or ° C depending upon whether English or metric units of level are chosen. Pressing ↓ allows you to continue to the next menu item.
Previous Menu <b>ENT</b> to select	Press <b>ENT</b> , ↓, or <b>DEL</b>	Pressing ↓ will cycle back to the Level display, or press <b>ENT</b> or <b>DEL</b> to continue to the next configuration item.

### SYSTEM CONFIGURATION MENU—LEVEL ONLY

This System Configuration menu is used for basic setup of the unit. Refer to pages 13 and 14 for the complete menu layout. The Model 300/301 is capable of being configured in three different modes of operation—**Level Only**, **Volume & Level**, or **Flow & Level**. The System Configuration Menu is for selecting the measurement units and calibrating the sys-

tem to measure **Level Only** (refer to page 15-16), **Volume & Level** (page 17), or **Flow & Level** (page 20).

The following table is a step-by-step procedure for using the **Level Only** menu. It is assumed that you are starting from the RUN mode.

System Configuration Menu (Level Only)		
Display	Keystroke	Comment and/or Additional Keystrokes
Magnetrol Int'l xxxx units	Press <b>ENT</b>	At start up, the unit is in the run mode displaying Magnetrol Int'l. Pressing <b>ENT</b> allows you to enter the main menu.
Measured Values <b>ENT</b> to Select	Press ↓	Allows you to enter the System Config menu.
System Config	Press <b>ENT</b>	Enters the first display (Level Units) of System Config. menu.
Level Units Inches	Press <b>ENT</b> or ↓	If inches are the desired Level Units press ↓ to continue to the next item. To change units, press <b>ENT</b> and ↓ to select Feet, Centimeters, or Meters. Press <b>ENT</b> to select desired Level Units.
Enter Password (if units changed)	Enter Valid Password (factory default is 300)	Entering a valid password and pressing <b>ENT</b> sets your unit selection and continues on to the next item.
Mode Setup Level Only	Press ↓	Press ↓ to continue to the next item. This section covers a Level Only configuration. Turn to page 17 if a Volume & Level configuration is desired, or page 20 for Flow & Level.

Continued on page 16

# SOFTWARE CONFIGURATION cont.

## SYSTEM CONFIGURATION MENU—LEVEL ONLY cont.

System Configuration Menu (Level Only) cont.		
Display	Keystroke	Comment and/or Additional Keystrokes
Range Setting xxxx units	Press <b>ENT</b> or ↓	Press <b>ENT</b> to change the range setting. If setting is correct press ↓ to continue to Span Settings. Refer to Figure 9.
<b>NOTE:</b> It is recommended to use Manual Set (as opposed to Auto Set) when changing the range or span settings.		
Manual Set xxxx units	Press <b>ENT</b> or ↓	Press <b>ENT</b> to manually set the range setting. An → will appear in the bottom line of the display. This allows you to change the range value. Measure the distance from the face of the transducer to the maximum distance to be measured. Enter value and press <b>ENT</b> . If Auto Set is preferred press ↓.
Auto Set (If chosen) xxxx units	Press <b>ENT</b> or ↓	The liquid surface must be at the maximum distance to be measured. Check to see that the distance being displayed is correct. When you press the <b>ENT</b> key, that distance will be set as your range and the program will continue on to the next selection. To continue without making changes press ↓.
<b>NOTE:</b> The span value is automatically set ONLY when the entered range value has decreased from its previous value.		
Span Setting xxxx units	Press <b>ENT</b> or ↓	Value shown will be 18 inches less than the range setting. This is the maximum span value available. If you want to reduce the span, press <b>ENT</b> . Refer to Figures 9 and 10. If the present setting is correct press ↓ to continue to Previous Menu.
Manual Set xxxx units	Press <b>ENT</b> or ↓	Press <b>ENT</b> to manually set the span setting. Measure the distance from the maximum range that was set to the highest point to be measured. Enter value and press <b>ENT</b> . If Auto Set is preferred press ↓.
Auto Set (If chosen) xxxx units	Press <b>ENT</b> or ↓	The liquid surface must be at the highest level to be measured. Check to see that the level being displayed is correct. When you press the <b>ENT</b> key, that measurement will be set as your span and the program will continue on to the next selection. To continue without changes press ↓.
Previous Menu <b>ENT</b> to select	Press <b>ENT</b>	Pressing the <b>ENT</b> key will set all values and return to System Config. Press <b>DEL</b> to return to the run mode.

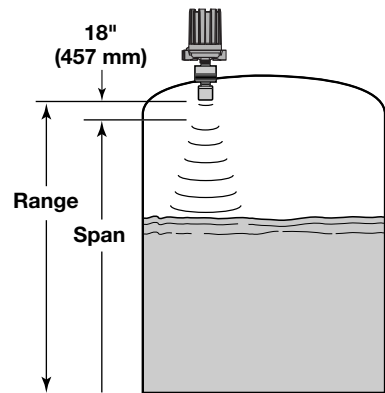

Figure 9

Maximum span should never be great enough to allow level measurement inside the nozzle, where the ultrasonic transducer is mounted.

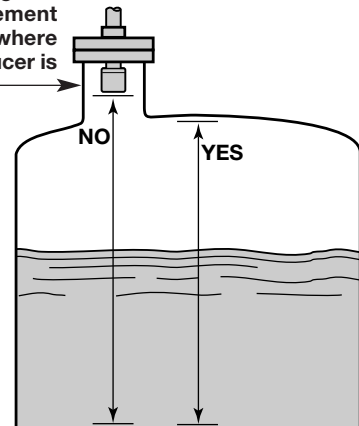

Figure 10

## SOFTWARE CONFIGURATION cont.

### SYSTEM CONFIGURATION MENU—VOLUME AND LEVEL

This menu is used to select the measurement units and configure the system to measure **Volume & Level**. Refer to page 15 for **Level Only** applications or page 20 for **Flow & Level** applications.

Following is a step-by-step procedure for using the Volume & Level menu. It is assumed that you are starting from the RUN mode.

System Configuration Menu (Volume and Level)		
Display	Keystroke	Comment and/or Additional Keystrokes
Magnetrol Int'l xxxx units	Press <b>ENT</b>	At start up, the unit is in the run mode displaying Magnetrol Int'l. Pressing <b>ENT</b> allows you to enter the main menu.
Measured Values ENT to Select	Press ↓	Allows you to enter the System Config menu.
System Config	Press <b>ENT</b>	Enters the first display (Level Units) of System Config menu.
Level Units Inches	Press <b>ENT</b> or ↓	If inches are the desired Level Units press ↓ to continue to the next item. To change units, press <b>ENT</b> and ↓ to select Feet, Centimeters, or Meters. Press <b>ENT</b> to select desired Level Units.
Enter Password (if units changed)	Enter Valid Password (factory default is 300)	Entering a valid password and pressing <b>ENT</b> sets your unit selection and continues on to the next item.
Mode Setup Level Only	Press <b>ENT</b>	Then press ↓ then <b>ENT</b> to change to Volume and Level mode.
Volume Units Cubic Feet	Press <b>ENT</b> or ↓	If cubic feet are the desired Volume Units, press ↓ to continue to the next item. To change units, press <b>ENT</b> and ↓ to select cubic inches, gallons, milliliters, or liters. Press <b>ENT</b> to select desired Volume Units.
Vessel Type Rectangular	Press <b>ENT</b> or ↓	Press <b>ENT</b> , ↓, then <b>ENT</b> to change present setting. You may select Rectangular, Horiz/Flat, Horiz/Ellip, Horiz/Sphere, Spherical, Verti/Flat, Verti/Ellip, Verti/Sphere, Verti/Conical or Custom Table (Refer to Figure 12 for Custom Table). If the present setting is correct (Rectangular), press <b>ENT</b> , input vessel dimensions, and then press ↓ to continue to next selection.
Radius= xxxx units (Vessel Dependent)	Enter value and press <b>ENT</b>	The values requested may vary depending on the type of vessel selected. Refer to vessel drawing for proper dimensions.
Width= xxxx units (Vessel Dependent)	Enter value and press <b>ENT</b>	The values requested may vary depending on the type of vessel selected. Refer to vessel drawing for proper dimensions.
Length= xxxx units (Vessel Dependent)	Enter value and press <b>ENT</b>	The values requested may vary depending on the type of vessel selected. Refer to vessel drawing for proper dimensions.
Range Setting xxxx units	Press <b>ENT</b> or ↓	Press <b>ENT</b> to change the range setting. If setting is correct, press ↓ to continue to Span Settings.
<b>NOTE:</b> It is recommended to use Manual Set (as opposed to Auto Set) when changing the range or span settings.		
Manual Set xxxx units	Press <b>ENT</b> or ↓	Press <b>ENT</b> to manually set the range setting. An → will appear in the bottom line of the display. This allows you to change the range value. Measure the distance from the face of the transducer to the maximum distance to be measured. Enter value and press <b>ENT</b> . If Auto Set is preferred press ↓.
Auto Set (If chosen) xxxx units	Press <b>ENT</b> or ↓	The liquid surface must be at the maximum distance to be measured. Check to see that the distance being displayed is correct. When you press the <b>ENT</b> key, that distance will be set as your range and the program will continue on to the next selection. To continue without making changes press ↓.
<b>NOTE:</b> The span value is automatically set ONLY when the entered range value has decreased from its previous value.		
Span Setting xxxx units	Press <b>ENT</b> or ↓	Value shown will be 18 inches less than the range setting. This is the maximum span value available. To reduce the span press <b>ENT</b> . If the present setting is correct press ↓ to continue to Previous Menu.
Manual Set xxxx units	Press <b>ENT</b> or ↓	Press <b>ENT</b> to manually set the span setting. Measure the distance from the maximum range that was set to the highest point to be measured. Enter value and press <b>ENT</b> . If Auto Set is preferred press ↓.
Auto Set (If chosen) xxxx units	Press <b>ENT</b> or ↓	The liquid surface must be at the highest level to be measured. Check to see that the level being displayed is correct. When you press the <b>ENT</b> key, that measurement will be set as your span and the program will continue on to the next selection. To continue without changes press ↓.
Previous Menu <b>ENT</b> to select	Press <b>ENT</b>	Pressing the <b>ENT</b> key will set all values and return to System Config. Press <b>DEL</b> to return to the run mode.

# SOFTWARE CONFIGURATION cont.

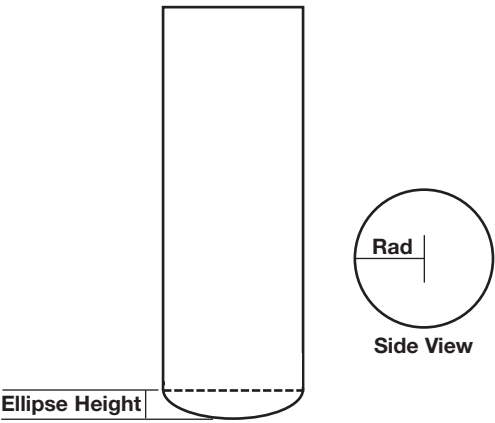

VERTICAL/ELLIPTICAL

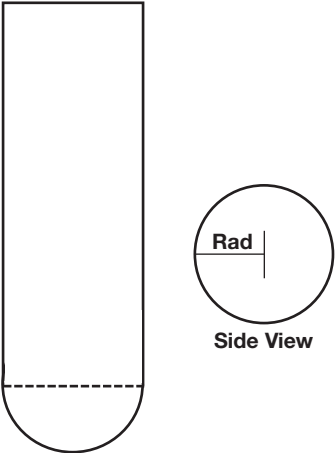

VERTICAL/SPHERICAL

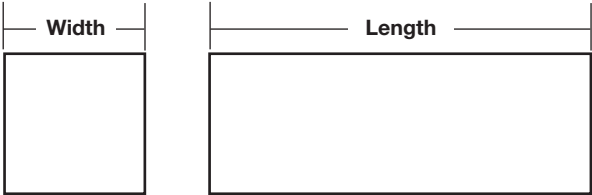

RECTANGULAR

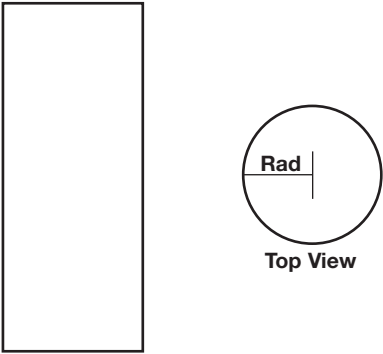

VERTICAL/FLAT

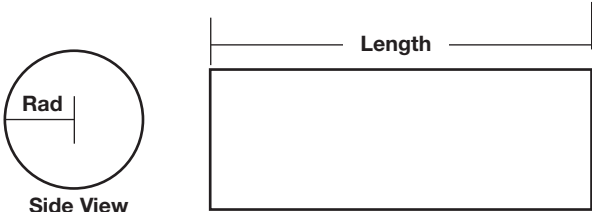

HORIZONTAL/FLAT

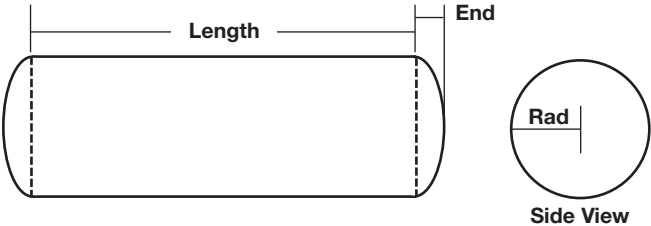

HORIZONTAL/ELLIPTICAL

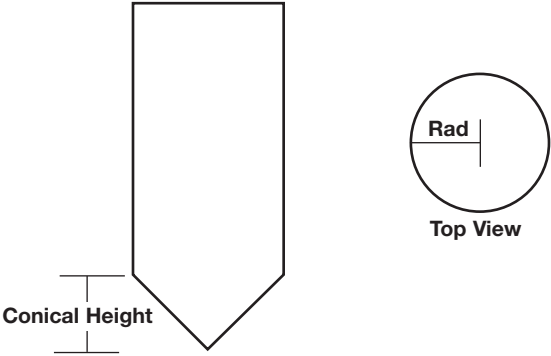

VERTICAL/CONICAL

Figure 11  
Vessel Drawings

# SOFTWARE CONFIGURATION cont.

## SYSTEM CONFIGURATION MENU—VOLUME AND LEVEL cont.

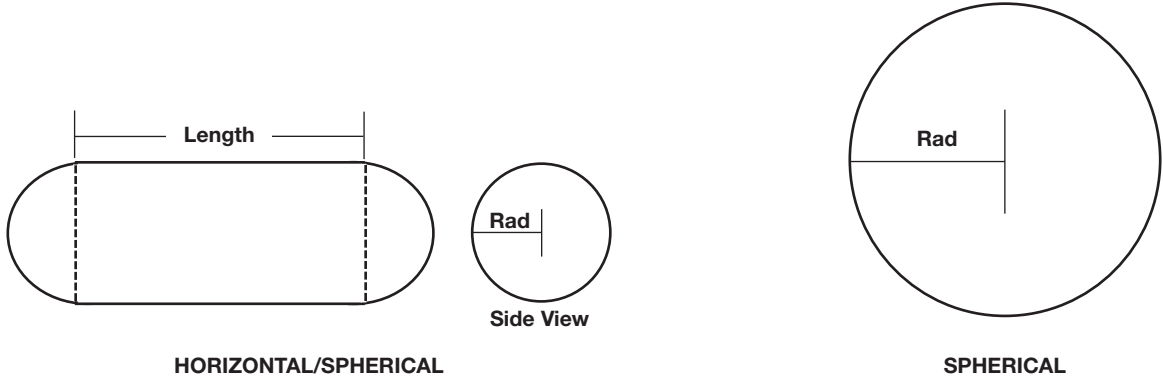
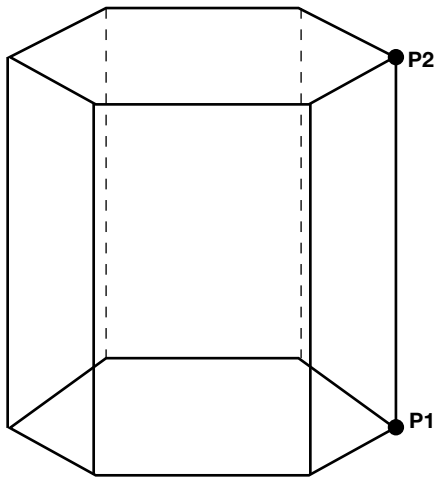
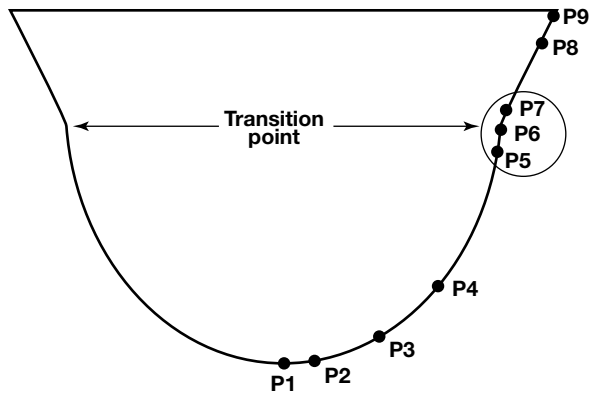

Figure 11  
Vessel Drawings cont.



LINEAR



Use where walls are not perpendicular to base.  
Concentrate at least two points at beginning (P1) and end (P9);  
and three points at either side of transition points.

SPLINE

Figure 12  
Custom Table (Volume and Level)

# SOFTWARE CONFIGURATION cont.

## SYSTEM CONFIGURATION MENU—FLOW AND LEVEL

This menu is used to select the measurement units and configure the system to measure **Flow & Level**. Refer to page 15 for **Level Only** applications or page 17 for **Volume & Level** applications.

Following is a step-by-step procedure for using the **Flow & Level** menu. It is assumed that you are starting from the RUN mode.

System Configuration Menu (Flow and Level)		
Display	Keystroke	Comment and/or Additional Keystrokes
Magnetrol Int'l xxxx units	Press <b>ENT</b>	At start up, the unit is in the run mode displaying Magnetrol Int'l. Pressing <b>ENT</b> allows you to enter the main menu.
Measured Values ENT to Select	Press ↓	Allows you to enter the System Config menu.
System Config	Press <b>ENT</b>	Enters the first display (Level Units) of System Config menu.
Level Units Inches	Press <b>ENT</b> or ↓	If inches are the desired Level Units press ↓ to continue to the next item. To change units, press <b>ENT</b> and ↓ to select Feet, Centimeters, or Meters. Press <b>ENT</b> to select desired Level Units.
Enter Password (if units changed)	Enter Valid Password (factory default is 300)	Entering a valid password and pressing <b>ENT</b> sets your unit selection and continues on to the next item.
Mode Setup Level Only	Press <b>ENT</b>	Then press ↓ twice, then <b>ENT</b> to change to Flow and Level mode.
Flow Units Cubic Feet/Second	Press <b>ENT</b> or ↓	If Cu ft/second are the desired Flow Units, press ↓ to continue to the next item. To change units, press <b>ENT</b> and ↓ to select Cu Ft/minute, Cu Ft/hour, Gals/minute, Gals/hour, Mil Gals/day, Liters/sec, Liters/minute, or Liters/hour. Press <b>ENT</b> to select desired Volume Units.
Flow Element Palmer Bowlus 4"	Press <b>ENT</b>	Press ↓ to select the proper type and size of flow element. Flow elements are listed on page 14. Press <b>ENT</b> to select desired flow element.
Reference Dist xx.xx units	Press <b>ENT</b>	The display will show Manual Set which allows you to enter the reference (range) value. Refer to Figures 14 and 15 for flume and weir side views.
<b>NOTE:</b> It is recommended to use Manual Set (as opposed to Auto Set) when changing the Reference Distance.		
Manual Set xxxx units	Press <b>ENT</b> or ↓	Press <b>ENT</b> to manually set the reference distance. An → will appear in the bottom line of the display. This allows you to change the reference value. Measure the distance from the face of the transducer to the maximum distance to be measured. Enter value and press <b>ENT</b> . If Auto Set is preferred press ↓.
Auto Set (If chosen) xxxx units	Press <b>ENT</b> or ↓	The liquid surface must be at the point of zero flow. Check to see that the distance being displayed is correct. When you press the <b>ENT</b> key, that distance will be set as your reference and the program will continue on to the next selection. To continue without making changes press ↓.
Maximum Flow xx.xx units	Press ↓	The unit will automatically display a value for Maximum Flow that is based on the Flow Element and Reference Distance that was entered. This can be decreased if desired, by entering a new value and pressing <b>ENT</b> .
Maximum Head xx.xx units	Press ↓	The unit will automatically display a value for Maximum Head that is based on the Flow Element and Reference Distance that was entered. This can be decreased if desired, by entering a new value and pressing <b>ENT</b> .
Low Flow Cutoff xx.xx units	Press ↓	When the flow values fall below the Low Flow Cutoff value, the flow value is driven to zero. The unit will automatically display a value 0.10 for the Low Flow Cutoff. This can be changed if desired, by entering a new value and pressing <b>ENT</b> .
Previous Menu <b>ENT</b> to select	Press <b>ENT</b>	Pressing the <b>ENT</b> key will set all values and return to System Config. Press <b>DEL</b> to return to the run mode.



# SOFTWARE CONFIGURATION cont.

## SYSTEM CONFIGURATION MENU—FLOW AND LEVEL cont.

Concentrate points as follows:

- A. At least two points at beginning (P1 and P2);
- B. At least two points at end (P9 and P10);
- C. Three points at approximate average flow rate (for example, P3, P4, P5); and at transition point (P7) and points on either side (P6, P8).

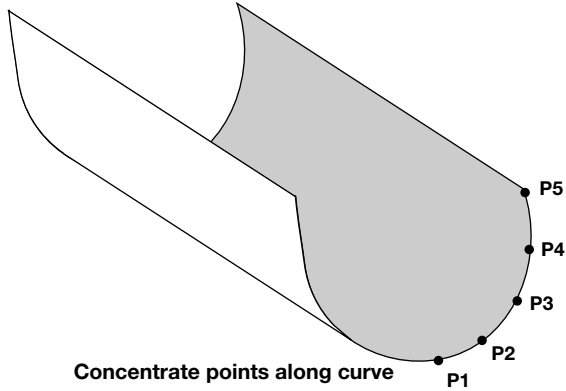

SPLINE OR LINEAR

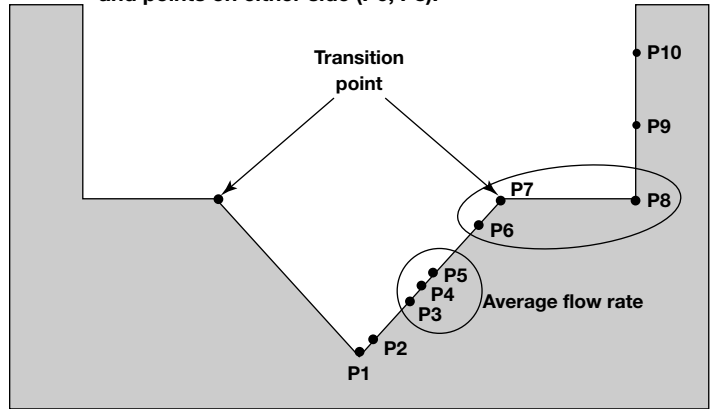

SPLINE

Figure 13  
Custom Table Flow and Level

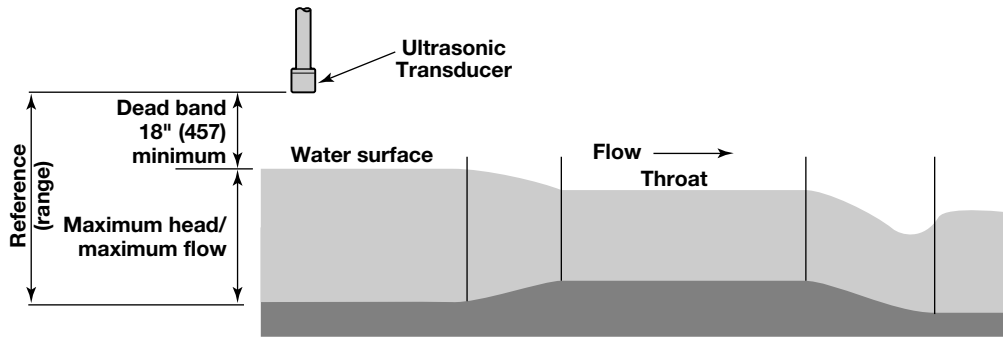

Figure 14  
Flume (side view)

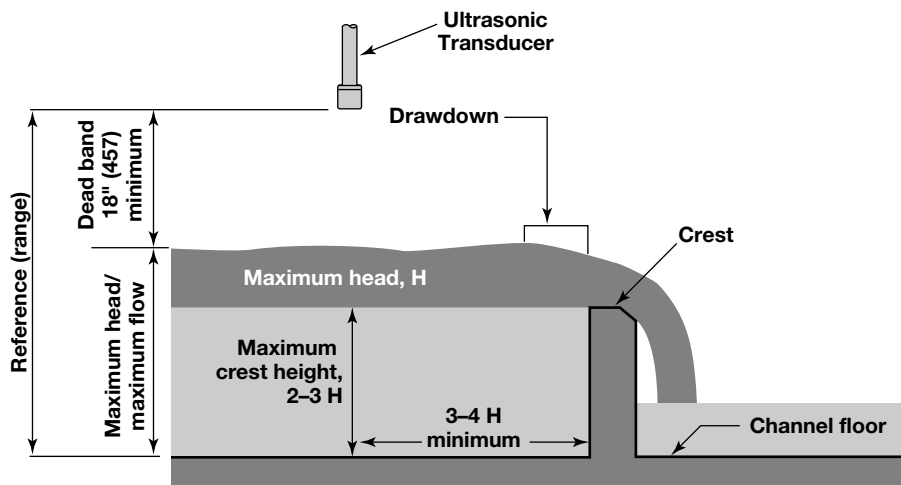

Figure 15  
Weir (side view)

**NOTE:** Install the transducer at the point recommended by the flume/weir manufacturer to insure proper flow measurement; or consult factory for transducer location.

# SOFTWARE CONFIGURATION cont.

## I/O CONFIGURATION MENU

This menu is used to configure the relay settings, 4–20 mA output, and communication parameters of the Model 300/301. Refer to pages 13 and 14 for the complete menu layout. The first part of this section shows how to configure

each type of relay (fault, alarm, and lead lag). The second part shows how to configure the 4-20 mA and RS-485 outputs. The I/O Configuration Menu can be entered from the RUN mode by pushing **ENT** and the pressing **↓** twice.

### RELAY SETTINGS

The 300/301 transmitter can be provided with four relays, two relays, or no relays. The relays can be configured to be fault (diagnostic) relays, alarm relays (controlled by level, volume, or flow), or lead lag (pump control) relays.

### Fault Relay Configuration

Relay #1 is the only relay that can be used as a fault relay to indicate when the diagnostics of the 300/301 have determined that there is a fault condition. There are six fault conditions that will change the state of relay #1 when a fault

occurs: echo loss, ringdown, transducer fail, no transducer, bad transducer, and temperature fail. See the Troubleshooting section for details on each of these fault conditions.

I/O Configuration Menu (Fault Relay #1 Setting)		
Display	Keystroke	Comment and/or Additional Keystrokes
I/O Config ←↓ to select	Press <b>ENT</b>	Enters the Relay Settings menu.
Relay Settings ←↓ to select	Press <b>ENT</b>	Allows entry into the Select Relay submenu.
Select Relay ←↓ to select	Press <b>ENT</b>	Allows configuration of relay.
Select Relay 1	Press <b>ENT</b>	Enters a submenu to configure relay #1.
Fault Relay (#1) Disable	Press <b>ENT</b>	Moves the <b>↕</b> to the bottom line of the LCD. This allows relay #1 to be enabled if it is to be used.
Fault Relay (#1) Disable	Press <b>↓</b>	Pressing <b>↓</b> enables the relay.
Fault Relay (#1) Enable	Press <b>ENT</b>	Moves the <b>↕</b> to the top line of the LCD.
Fault Relay (#1) Enable	Press <b>↓</b>	Moves to the next item.
Relay On Delay 1 sec	Press <b>ENT</b> or <b>↓</b>	A one-second delay on the relay is preset from the factory to prevent relay chattering during turbulent process conditions. Press <b>↓</b> to keep this at one second, or press <b>ENT</b> to change it to a different (0-255 seconds) value.
Relay Off Delay 1 sec	Press <b>ENT</b> or <b>↓</b>	Press <b>↓</b> to keep this at one second, or press <b>ENT</b> to change it to a different (0-255 seconds) value.
Previous Menu ←↓ to select	Press <b>ENT</b>	Reverts back to the Select Relay submenu.

# SOFTWARE CONFIGURATION cont.

## I/O CONFIGURATION MENU cont.

### Alarm Relay Configuration

Any of the relays can be configured as alarm relays. Each alarm relay can be configured to be controlled by Level, Volume (when in **Volume & Level** mode), or Flow (when in the **Flow & Level** mode).

The alarm relays can be configured to have the same on and off points, or different on and off points.

I/O Configuration Menu (Alarm Relay Setting)		
Display	Keystroke	Comment and/or Additional Keystrokes
I/O Config ↕ ←↓ to select	Press <b>ENT</b>	Enters the Relay Settings menu.
Relay Settings ↕ ←↓ to select	Press <b>ENT</b>	Allows entry into the Select Relay submenu.
Select Relay ↕ ←↓ to select	Press <b>ENT</b>	Allows configuration of relay.
Select Relay 1	Press <b>ENT</b> or 2, 3, or 4	Press <b>ENT</b> to begin configuring relay #1 (if it was not used as a Fault relay) or enter 2, 3, or 4 to configure the other relays.
Fault Relay (#1) Disable ↕	Press ↓	Fault Relay (#1) will be displayed only if you are configuring relay #1. Press ↓ to keep it disabled as a fault relay, and proceed to configure it as an alarm relay.
Enable/Disable Disable ↕	Press <b>ENT</b> and ↓	Enables the relay. After enabling the relay press <b>ENT</b> again to move the ↕ back up to the top line, and then press ↓ to proceed to the next item.
Controlled By Level ↕	Press <b>ENT</b> or ↓	If the unit is in the <b>Level Only</b> mode, this screen will not be shown. If the unit is in the <b>Volume &amp; Level</b> , or <b>Flow &amp; Level</b> modes, the relay can be used to control level, volume or flow. Pressing ↓ will set the relay to be controlled by level. Press <b>ENT</b> , ↓, <b>ENT</b> , and ↓ if controlling by volume or flow if desired.
Relay On Point xxxx units ↕	Press <b>ENT</b>	Inserts a → on the bottom line of the LCD which allows the value to be changed. Enter the value for the on point and then press <b>ENT</b> and ↓.
Relay Off Point xxxx units ↕	Press <b>ENT</b>	Inserts a → on the bottom line of the LCD which allows the value to be changed. Enter the value for the off point and then press <b>ENT</b> and ↓.
Relay Action DNRG < Setpoint ↕	Press <b>ENT</b> or ↓	This screen will only appear if the "Relay On" and "Relay Off" points are the same. Select either "DNRG<Setpoint" to have the relay de-energize at a value that is less than the set point (low level fail-safe), or "DNRG>Setpoint" to have the relay de-energize at a value that is greater than the set point (high level fail-safe).
Relay On Delay 1 sec ↕	Press <b>ENT</b> or ↓	A one-second delay on the relay is preset from the factory to prevent relay chattering during turbulent process conditions. Press ↓ to keep this at one second, or press <b>ENT</b> to enter a different (0-255 seconds) value.
Relay Off Delay 1 sec ↕	Press <b>ENT</b> or ↓	Press ↓ to keep this at one second, or press <b>ENT</b> to enter a different (0-255 seconds) value.
Fault Mode OFF on FAULT ↕	Press <b>ENT</b> or ↓	If the unit detects one of the six fault conditions described in Fault Relay Configuration (page 22), the alarm relays can either be configured to turn OFF (de-energize) or to HOLD their current state. The factory default setting is OFF.
Previous Menu ←↓ to select ↕	Press <b>ENT</b>	Reverts back to the Select Relay submenu.

### Lead-Lag Relays

As shown in the General Programming Menu on page 14, all four relays can be included in a lead-lag group for pump control. The factory default setting is OFF for the lead-lag mode. To set-up relays in a lead-lag group, the lead-lag mode must be changed to one of the following five selections: 1-2, 1-2-3, 1-2-3-4, 2-3, or 2-3-4. If relay #1 is configured as a fault relay (page 22), then 2-3 and 2-3-4 are the only two possible relay groupings for lead-lag control of pumps. If relay #1 is not configured as a fault relay, then the lead-lag group selections are 1-2, 1-2-3, or 1-2-3-4.

When configuring the lead-lag mode you will see the following warning message: **No Alarm Relays in LeadLag Group**. This message means that any relays that are included in the lead-lag group must have different on and off points. The software does not allow any individual relays in the lead-lag group to have the same on and off points. See Figure 16 on the next page for further explanation.

# SOFTWARE CONFIGURATION cont.

## I/O CONFIGURATION MENU cont.

### Lead-Lag Relays cont.

Since the configuration for relays in a lead-lag group is the same as alarm relays, refer to page 23 for configuration. The DNRG < Setpoint screen will not be shown since lead-lag relays cannot have the same value for “Relay On” and “Relay Off.”

As shown in Figure 16, all the RELAY OFF points in the lead-lag group should be the same value. This allows the lead-lag cycle to reset when more than one relay comes on. The RELAY ON points for the second, third, and fourth relays (if used), are staggered above the RELAY ON point for the first relay.

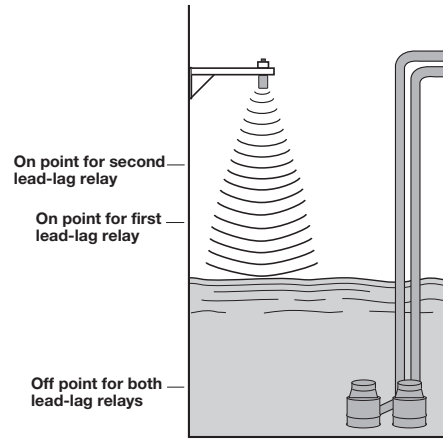

**Figure 16**  
Lead-lag Relay Configuration

### 4-20 mA OUTPUT AND RS-485 SETTINGS

The 4-20 mA output can be controlled by either level, volume, or flow depending on which mode was selected in the System Configuration Menu.

The RS-485 menu configures the Modbus digital communications port of the unit.

I/O Configuration Menu (4-20 mA Output Settings)		
Display	Keystroke	Comment and/or Additional Keystrokes
I/O Config ↕ ←↓ to select	Press <b>ENT</b>	Enters the Relay Settings menu.
Relay Settings ↕ ←↓ to select	Press ↓	Scrolls to the 4-20 mA Settings submenu.
4-20 mA Settings ↕ ←↓ to select	Press <b>ENT</b>	Enters the 4-20 mA Settings submenu.
Enable/Disable ↕ Disable	Press <b>ENT</b> , ↓	Enables the 4-20 mA output. Press <b>ENT</b> and ↓ to proceed to the next item.
Controlled by ↕ Level	Press <b>ENT</b> or ↓	If unit is configured in the <b>Level Only</b> mode, this screen will not be displayed. Press ↓ to have the 4-20 mA controlled by level, or <b>ENT</b> , ↓, <b>ENT</b> , ↓ to have it controlled by volume or flow.
4 mA Point ↕ xxxx units	Press <b>ENT</b>	Inserts a → on the bottom line of the LCD which allows entry of the 4 mA point value. After entering the 4 mA value, press <b>ENT</b> and ↓.
20 mA Point ↕ xxxx units	Press <b>ENT</b>	Inserts a → on the bottom line of the LCD which allows entry of the 20 mA point value. After entering the 20 mA value, press <b>ENT</b> and ↓.
Fault Mode ↕ Hold	Press <b>ENT</b>	Determines the status of the 4-20 mA if a system fault is detected. Use the ↓ to select either Hold, 22 mA, or 3.5 mA then press <b>ENT</b> and ↓.
Previous Menu ↕ ←↓ to select	Press <b>ENT</b>	Reverts back to the 4-20 mA Settings menu.

I/O Configuration Menu (RS-485 Settings)		
Display	Keystroke	Comment and/or Additional Keystrokes
I/O Config ↕ ←↓ to select	Press <b>ENT</b>	Enters the Relay Settings menu.
Relay Settings ↕ ←↓ to select	Press ↓ twice	Scrolls to the Communication Port Setup submenu.
Comm Port Setup ↕ ←↓ to select	Press <b>ENT</b>	Enters the Communication Port Setup submenu.
Address (0-247) ↕ 1	Press ↓ or <b>ENT</b>	This screen is used to set the address for this particular unit during polling. Enter the address via the keypad. Make sure that no other unit uses this same address.
Baud Rate ↕ 9600	Press ↓ or <b>ENT</b>	Set the baud rate (communication speed) for the unit. Baud rates of 9600, 4800, 2400, or 1200 are available. Enter the baud rate via the keypad. This value must match the Modbus settings of your system.
Parity ↕ Even	Press ↓ or <b>ENT</b>	Set the parity bit at Even, Odd, or None via the keypad. This value must match the Modbus settings of your system.
Previous Menu ↕ ←↓ to select	Press <b>ENT</b>	Reverts back to the Communication Port Setup.

# SOFTWARE CONFIGURATION cont.

## ADVANCED CONFIGURATION MENU

The Advanced Configuration menu sets many parameters that are not normally used in the operation of the unit. The Advanced Configuration menu can be accessed from the run mode by pressing **ENT** and  $\uparrow$  or  $\downarrow$  until the display shows:

```
Adv Config  ⬆
⬅ to select
```

The entire Advanced Configuration menu is shown below, followed by the configuration instructions for each item.

Advanced Configuration Menu	
Menu Display	Menu Item Explanation
Adv Config ⬅ to select	Enters the Advanced Configuration menu. Press <b>ENT</b> .
Calibrate xxxx units	Used to adjust for the speed of sound if the ultrasonic signal is going through media other than air. <b>NOTE: It is strongly recommended</b> to consult the factory prior to using this feature!
Gain Limit 32	Used to limit the gain to a value between 0 and 32. Since the unit adapts its gain to suit the application, it is not recommended to use this feature unless instructed to by the factory.
Starting Gain 0	Used to adjust the starting gain to a value between 0 and 32. Since the unit adapts its gain to suit the application, it is not recommended to use this feature unless instructed to by the factory.
Damping (1-60) 6	Used to set the damping (1-60 seconds) for the unit. This value can be changed depending on how turbulent the process is, or if the rate of fill is very fast or slow.
Echo Loss Delay 1 sec	Used to set a delay (1-150 seconds) of the Fault Alarm (relay #1) when an echo loss occurs.
Default Display Level	Allows the default display to be changed from <b>Level</b> to <b>Loop</b> (4-20 mA), or <b>Volume</b> or <b>Flow</b> if in the <b>Volume</b> or <b>Flow</b> mode.
Change Password ⬅ to select	The factory preset password is 300. This screen is used to change the password for security purposes.
Adjust Loop Pts ⬅ to select	Offsets to the mA current loop can be made.
Enter Tag Line ⬅ to select	Used to replace the "Magnetrol Int'l" tag with a user-defined tag such as vessel number or location. Any alphanumeric characters can be entered as a tag.
Previous Menu ⬅ to select	Reverts back to the beginning of Advanced Configuration.

### Calibrate

**NOTE:** It is not recommended to use the calibrate feature unless specifically directed to do so from the factory.

The Model 300/301 performs level measurement by timing how long it takes for a round trip ultrasonic pulse to travel from the face of the transducer to the liquid surface and back. The measurement assumes that this round trip is in air where the speed of sound is 1128 feet/second. This speed of sound is altered when going through gases other than air. The Calibrate mode can be used to adjust for the speed of sound when going through homogenous (not stratified layers) gases other than air. However, since most gases exist as stratified layers of vapors above the liquid surface, the Calibrate mode is rarely used.

When entering the Calibrate mode, the display will indicate the distance that the 300/301 has measured from the face of the transducer to the liquid surface. If this distance is in error, measure the actual distance and enter this value.

**NOTE:** Using the Calibrate mode may cause false level readings. Consult factory for reset procedures.

### Gain Limit

This displays the value of maximum gain that the unit will use. This value is from 0-32 and the unit steps up in single-gain increments until a suitable signal is received. Limiting the gain to a lower value may help with secondary echo problems.

Enter a value between 0 and 32. Enter Password will be displayed and your chosen password must be entered at this time. Press **ENT** to acknowledge the password.

### Gain Limit cont.

The Model 300/301 adapts its gain to suit the conditions of the application. There are 32 gain steps. The higher the number, the higher gain/drive required to detect an acceptable signal.

### Starting Gain

The gain starts out at a value of zero and adjusts itself to a value (between 0 and 32) such that it can reliably measure the liquid surface. Approximately once a minute it will reinitialize the gain starting from zero to make sure that the unit is measuring the proper distance. This is particularly helpful in tall vessels or those applications with turbulent surfaces. A higher Starting Gain value will decrease the time for the unit to achieve the proper Gain value. Adjusting the starting gain should not be done without consulting the factory.

### Damping

The factory default value is 6 seconds for damping. This value can be changed (from 1-60) depending on the rate of fill (or empty) of the vessel. Larger damping values can be beneficial if the liquid surface is turbulent due to the vessel fill, or agitation from a mixer.

### Echo Loss Delay

Used to set a delay (1-150 seconds) of the Fault Alarm (relay #1) when an echo loss occurs. This helps to avoid a fault alarm if the 300/301 momentarily loses the ultrasonic signal due to excessive turbulence, foam or other application parameters.

# SOFTWARE CONFIGURATION cont.

## ADVANCED CONFIGURATION MENU cont.

### Default Display

The factory default is for the unit to display Magnetrol Int'l on the top line of the LCD while in the run mode, and a level reading on the bottom line. The bottom line can be changed to display the mA current loop output value instead of the level reading. When using the **Volume & Level** mode, the default display can be changed to be volume. When using the **Flow & Level** mode the default display can be changed to be flow.

### Change Password

Allows for the factory preset password of 300 to be changed to another value for security purposes. The password can be any number between 1 and 32767. The format is to enter the old password, enter the new password, and then enter the new password again.

### Adjust Loop Points

Offsets to the mA current loop can be made if necessary. This is done by reading the mA current output with a DVM, and adjusting the 3.5 mA and 22 mA endpoints with

### Adjust Loop Points cont.

the  $\uparrow$  or  $\downarrow$  keys. These values are set at the factory and should not need to be adjusted. Contact the factory prior to making any adjustments to the loop output.

### Enter Tag Line

The upper line of the LCD display while in the run mode is a programmable label referred to as the tag. It is preset at the factory as "Magnetrol Int'l." If desired, this tag can be changed to be any alphanumeric string of 16 characters. Press **ENT** and then use  $\uparrow$  or  $\downarrow$  to scan through the characters. Pressing **ENT** will enter a character and move the cursor to the next position on the LCD line. Upper and lower case letters are provided as well as numbers and many ASCII characters. Pressing **DEL** moves the cursor back one position. Pressing the  once will start a scrolling of the characters, and pressing it twice will start a fast scrolling. When close to the desired character, press **ENT** and use  $\uparrow$  or  $\downarrow$  to reach the desired character. A blank space may also be used. The blank space is found in between the ! and the  $\rightarrow$  while scrolling through the characters.

## DIAGNOSTICS MENU

The Diagnostics Menu provides a method of testing the instrument's functionality. It also has useful information for troubleshooting. Access to Diagnostics Menu is obtained from the run mode by pushing either the  $\uparrow$  or  $\downarrow$  arrows until the display shows:

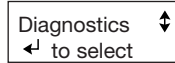

Diagnostics Menu			
Display	Option	Action if ENT is pressed	Comments
Test Relays $\leftarrow$ to select	Press <b>ENT</b> to change or $\uparrow$ or $\downarrow$ to continue.	Select relay to test, press ENT, then use $\uparrow$ or $\downarrow$ to energize relay.	Allow user to energize any relay individually. Press ENT when complete.
Test 4-20 mA Loop $\leftarrow$ to select	Press <b>ENT</b> to change or $\uparrow$ or $\downarrow$ to continue.	Enter desired current output and press <b>ENT</b> .	Allows user to output desired 4-20 mA to an external device. Press <b>ENT</b> when complete.
Gain/ % Signal xx    xxx	Press $\uparrow$ or $\downarrow$ to continue.	This is a read-only screen that cannot be changed.	The gain will increase (from 0 to 32) to keep the % signal strength at a desired level for peak performance.
View Version # xxxxxxxxxx	Press $\uparrow$ or $\downarrow$ to continue.	Display software version number.	
Previous Menu $\leftarrow$ to select	Press <b>ENT</b> to return to previous menu or $\uparrow$ or $\downarrow$ to review selection.		



# MODBUS PROTOCOL

## IMPLEMENTATION

This protocol guide explains the operation of the Modbus protocol per Modicon document PI-MBUS-300 Rev J.

The Magnetrol implementation of the Modbus protocol provides a standard form of digital communications. An effort has been made to parallel current implementations to the greatest extent possible, so that Magnetrol products communicate with existing Modbus masters.

Check compatibility carefully to ensure that the Model 300/301 is configured for the data format expected by the host computer. Exceptions made because of the unique requirements of the Magnetrol installation have been noted. This is no guarantee, however, that the interpretation made here will be the same as that followed by the Modbus master.

The Magnetrol implementation of the Modbus protocol provides for the passing of measured and calculated variables, configuration information, and diagnostics in data registers. Data is sent in these registers as floating point values, integer values, numeric codes related to configuration lists, status summary words (packed bits), or individual flags (single bits).

One master and up to 31 units may be multi-dropped on a single RS-485 communication bus.

The Modbus functions implemented in Model 300/301 are listed in Table 3.

## CONFIGURATION

The Modbus port on the Model 300/301 must be configured to establish communications. The keypad allows the user to set the Magnetrol Modbus port to match the Modbus master. See page 24 for configuration instructions.

Magnetrol addresses provide unique identification for the host. This address may range from 1 to 247 and must be unique. Each Model 300/301 only responds when a query has been sent to its unique address by the host.

Magnetrol units support the Remote Terminal Unit (RTU) mode of transmission. RTU provides improved error detection capabilities and higher throughput than the ASCII mode.

The RS-485 port must be configured for a transmission speed (baud rate). Allowable values are 1200, 2400, 4800, or 9600 bits per second.

**Table 3 Modbus Functions**

Function Code	Function	Information Type	MODBUS Nomenclature
01	Read	1-bit coils	Read coil status
02	Read	1-bit coils	Read input status
03	Read	16-bit register/integer	Read holding registers
04	Read	16-bit register/integer	Read input registers
05	Write	16-bit register/coils	Force single coil
06	Write	16-bit register	Preset single register
15	Write	16-bit register/coils	Force multiple coils
16	Write	16-bit register	Preset multiple registers

Exception:  
Because the Model 300/301 does not distinguish between inputs and outputs, function codes 01 and 02 (as they apply to bits) and function codes 03 and 04 (as they apply to numeric values) refer to the same data registers.

# FUNCTIONS AND DATA FORMAT

The Modbus data in the Model 300/301 is arranged in integer register, floating point registers, and status bits. The assignments for these registers are found in the tables on pages 30 and 31. Function codes 03, 04, 06, and 16 are used with integer registers.

Function codes 01, 02, 05, and 15 are used with status bits. Both integer and floating-point registers have space reserved to reorder the registers for maximum communication throughput.

A complete description of all the preceding commands, except floating point, can be found in Modicon Modbus Protocol Reference Guide, document number PI-MBUS-300 Rev J.

## INTEGER REGISTERS

Integer registers are the most commonly used type of Modbus data and are supported by most Modbus hosts. In the Magnetrol implementation, the Modbus registers are arranged in one of the following four formats:

1. Integer Data: A scaled number from 0 to the maximum Modbus integer.
2. Character Data: Two ASCII characters per 16-bit register (i.e., date, password).
3. Coded Data: Multiple choice configuration data chosen from a coded list.
4. Packed Bits: Register form of 16 packed single bits

The integer, character, and coded data registers contain all of the information needed to configure and read process data. Any integer register may be read with function code 03 or function code 04. These same registers may be written one at a time with function code 06 or multiple registers can be written with function code 16.

# PROGRAMMING

The serial communication for the Model 300/301 is designed to communicate with a host computer over two wires in a multidrop system.

Each transmitter in the system is assigned a unique address that the computer uses to communicate with that transmitter.

## COMMAND/RESPONSE SEQUENCE

The system uses half duplex communication with the host computer acting as the master and the 300/301 transmitters acting as the slaves. The 300/301 transmitter is designed for 1 master computer and up to 32\* slaves. Each slave has a unique address between 1 and 247 associated with it. The address is used to wake up the transmitter and interrogate it for data.

The host will send down a command to the unit using the address to wake it up. The unit will then analyze the command and retrieve the appropriate data. After sending back a response, the unit will return to the sleep mode.

Only the host computer can issue a command. Each command contains the unit address, the function code, the data, and the error checking valve. Magnetrol products support the CRC error checking valve.

\*See cable requirements for the maximum number of units allowed for intrinsically safe operation.

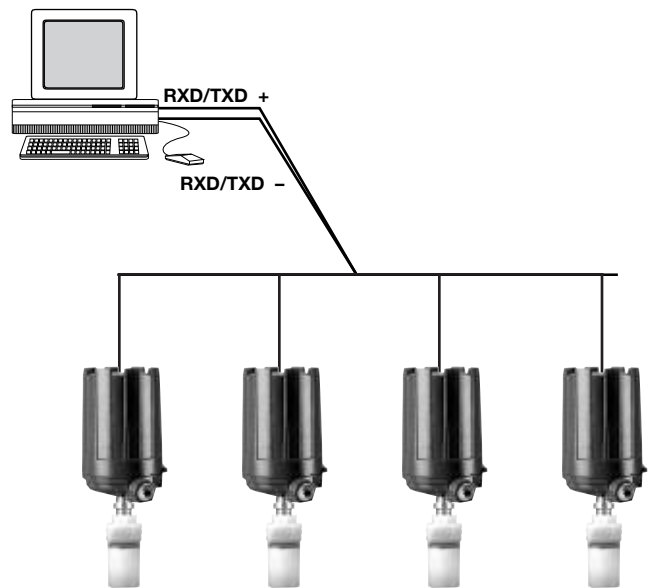

Figure 17

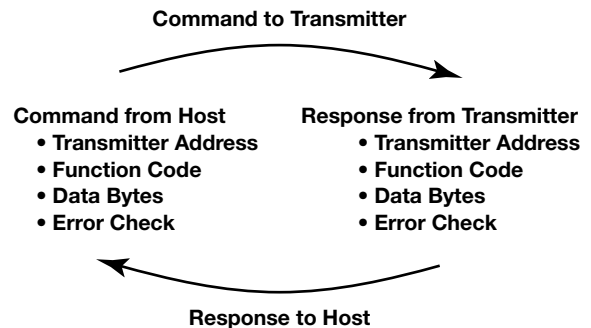

Figure 18

## PROGRAMMING cont.

### CHARACTER FRAMING

The Model 300/301 is factory configured for 9600 baud, even parity, and 1 stop bit. In serial communication, the bits are sent out one at a time, least significant bit first. These are surrounded by a start bit (always low) and a parity bit or a stop bit (if a parity bit, it will be followed by a stop bit) (always high).

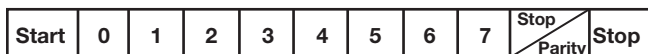

Figure 19

### MESSAGE FRAMING

All messages start and end with an idle time of 3.5 character times. For the 300/301 this value is approximately 4 ms at 9600 baud. This will let all the units know that the next byte to follow is the address field.

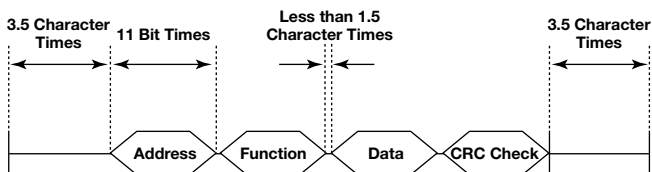

Figure 20

Because of this method for determining the address byte, the entire message must be sent in a continuous stream. If an idle time of more than 1.5 character times occurs before the completion of the message, the next byte received will be assumed an address byte and the previously received bytes will be ignored.

### MEMORY MAP

Modbus sets up the data in a memory map. The memory map is set up in registers that are 2 bytes in length. The read only registers are numbered from 30001 to 39999. The read/write registers are numbered from 40001 to 49999. In order to access these registers, an offset is sent. For example, if the data in register 30001 is to be read, an offset of 0000 is sent.

Individual bits in the bit registers are addressed by a separated map. The read only bits are numbered from 10000 to 19999 and the read/write bits are numbered from 0 to 9999. In the XXXX unit, both addresses will access the same bit. The offset for these bits is the same as the registers. For example, if 10003 is to be read, and offset of 0002 is sent.

### MODEL 300/301 MODBUS MAPPING

A maximum and minimum value of 0 indicates that the value is Read Only. Care must be taken when disabling relays. The relay will hold the last state when it is disabled. RS-485 is used for external communications using Modbus.

The Model 300/301 Transmitter uses the Modbus RTU protocol. The user must enter the BAUD rate and the parity that the master will be using. See page 24 for configuration instructions. Each of these parameters must be set at the unit before communication can occur.

1. BAUD rate: 1200, 2400, 4800, 9600.
2. Parity: Odd (8, O, 1), Even (8, E, 1), or None (8, N, 2).

## PROGRAMMING cont.

### MODEL 300/301 MODBUS MAPPING cont.

#### 1-BIT COIL VALUES

Command	Register #	Comments
Forces Loop to Loop Force Value	00001	Forces loop to loop force value On/Off
Enables Loop Control	00002	Enables loop control On = Enable; Off =Disable
Relay #1 to Force On Value	00003	Relay #1 diagnostic test On = Enable; Off = Disable (normal operation)
Force On Value (Relay #1)	00004	Off = De-Energized; On= Energized
Relay #2 to Force On Value	00005	Relay #2 diagnostic test On = Enable; Off = Disable (normal operation)
Force On Value (Relay #2)	00006	Off = De-Energized; On= Energized
Relay #3 to Force On Value	00007	Relay #3 diagnostic test On = Enable; Off = Disable (normal operation)
Force On Value (Relay #3)	00008	Off = De-Energized; On= Energized
Relay #4 to Force On Value	00009	Relay #4 diagnostic test On = Enable; Off = Disable (normal operation)
Force On Value (Relay #4)	00010	Off = De-Energized; On= Energized
Enable Relay #1	00011	Off = Disable; On = Enable
Relay Action for Relay #1	00012	Off = DNRG <Set point; On = DNRG > Set point
Relay #1 as Fault Relay Setting	00013	Off = Normal; On = Fault (Read Only —Functions 1 or 2)
Enable Relay #2	00014	Off = Disable; On = Enable
Relay Action for Relay #2	00015	Off = DNRG < Set point; On = DNRG > Set point
Enable Relay #3	00016	Off = Disable; On = Enable
Relay Action for Relay #3	00017	Off = DNRG < Set point; On = DNRG > Set point
Enable Relay #4	00018	Off = Disable; On = Enable
Relay Action for Relay #4	00019	Off = DNRG < Set point; On = DNRG > Set point

#### 16-BIT REGISTER VALUES

Command	Register #	Comments	Minimum Decimal Value	Maximum Decimal Value	Maximum Hex Value
Damping	40001	Output damping values in seconds	1	60	0 x 3C
Units	40002	1 = inches; 2 = feet; 3 = centimeters; 4 = meters	1	4	0 x 04
Lead-Lag Relay Select	30003	Refer to Lead-Lag group size table* (read only—functions 3 or 4)	3	15	0 x 0F
Lead-Lag Relay Quantity	30004	Refer to Lead-Lag group size table* (read only—functions 3 or 4)	2	4	0 x 04
On Time Delay — Relay #1	40005	Time delay before relay energize (seconds)	0	255	0 x FF
Off Time Delay — Relay #1	40006	Time delay before relay de-energize (seconds)	0	255	0 x FF
On Time Delay — Relay #2	40007	Time delay before relay energize (seconds)	0	255	0 x FF
Off Time Delay — Relay #2	40008	Time delay before relay de-energize (seconds)	0	255	0 x FF
On Time Delay — Relay #3	40009	Time delay before relay energize (seconds)	0	255	0 x FF
Off Time Delay — Relay #3	40010	Time delay before relay de-energize (seconds)	0	255	0 x FF
On Time Delay — Relay #4	40011	Time delay before relay energize (seconds)	0	255	0 x FF
Off Time Delay — Relay #4	40012	Time delay before relay de-energize (seconds)	0	255	0 x FF
Current Relay Status	30013	Data contained in lower byte All "Off" = 0000; All "On" = 000F	0	15	0 x 0F
Loop Control Bits	40014	Bit 0: Set to 0 Bit 1: 1 = enable; 0 = disable Bit 2: Set to 0 Bit 4-3: Fault mode: 01 = 22 mA 10 = 3.5 mA 11 = Hold  Bits 5-7: Set to 0 Bits 8-15: Set to 0	0	26	0 x 1A

## PROGRAMMING cont.

### 16-BIT REGISTER VALUES cont.

Command	Register #	Comments	Minimum Decimal Value	Maximum Decimal Value	Maximum Hex Value
Relay #1 Control Bits	40015	Bit 0: 1 = enable; 0 = disable Bit 1: Relay action	0	27	0 x 1B
Relay #2 Control Bits	40016	0 = DNRG < set point 1 = DNRG > set point			
Relay #3 Control Bits	40017	Bit 2: Set to 0			
Relay #4 Control Bits	40018	Bit 4–3: Fault Mode: 00 = De-energize 01 = Hold Bits 5–15: Set to 0			
Diagnostic Bits	30019	Bit 0–7: Set to 0 Bit 8: 1 = No return signal; 0 = No error Bit 9: 1 = Ringdown error; 0 = No error Bit 10: 1 = Transducer fault; 0 = No error Bit 11: 1 = No transducer; 0 = No error Bit 12: 1 = Bad transducer; 0 = No error Bit 13: 1 = Temperature fault; 0 = No error Bit 14–15: Set to 0 (read only — functions 3 or 4)			
Relay #1 Force Control Bits	40020	Bit 0: Force relay to forced state 1 = enable; 0 = disable (normal operation)	0	3	3
Relay #2 Force Control Bits	40021	Bit 1: Forced relay state 1 = Energize; 0 = De-energize			
Relay #3 Force Control Bits	40022	Bits 2–15: Set to 0			
Relay #4 Force Control Bits	40023				
Level Reading	30024	Level reading (level in inches x 10)			
Flow/Volume Reading	30025	Flow/volume reading (x 10)			
4–20 mA Reading	30026	4–20 mA reading (x 10)			
Range	40027	Range value (x 10)			
Span	40028	Span value (x 10)			
4–20 mA Force	40029	Loop value for loop diagnostics (x 10)	35	220	0 x DC
4 mA Point	40030	4 mA Point (level in inches x 10)	0	4800	0 x 12C0
20 mA Point	40031	20 mA point (level in inches x 10)	0	4800	0 x 12C0
Relay #1 Off Point	40032	Point in inches (x 10)	0	4800	0 x 12C0
Relay #1 On Point	40033	Point in inches (x 10)	0	4800	0 x 12C0
Relay #2 Off Point	40034	Point in inches (x 10)	0	4800	0 x 12C0
Relay #2 On Point	40035	Point in inches (x 10)	0	4800	0 x 12C0
Relay #3 Off Point	40036	Point in inches (x 10)	0	4800	0 x 12C0
Relay #3 On Point	40037	Point in inches (x 10)	0	4800	0 x 12C0
Relay #4 Off Point	40038	Point in inches (x 10)	0	4800	0 x 12C0
Relay #4 On Point	40039	Point in inches (x 10)	0	4800	0 x 12C0

### \*LEAD-LAG GROUP SIZE (REGISTER 30003, 30004)

Lead-Lag Relay Select	Lead-Lag Relay Quantity	Description
0 x 03	2	Relays 1 & 2
0 x 07	3	Relays 1, 2, & 3
0 x 0F	4	Relays 1, 2, 3, & 4
With Relay 1 set as a Fault Relay		
0 x 06	2	Relay 2 & 3
0 x 0E	3	Relay 2, 3, & 4

# RS-485 WIRING

Standard Belden 8451 shielded, twisted pair, 22-gauge stranded conductors may be used for interconnection of units. Order cable through Magnetrol (part number, 009-7146-001), specify length at the time of order; 10 feet (3 m) minimum, 5000 feet (1524 m) maximum.

The preferred method of wiring is that all units be wired in parallel. It is permissible to have branches, not exceeding five feet, from the main wiring trunk. One master with a maximum of 31 slave devices is allowable.

1. Connect terminal A from the master device to terminal A on all slave devices.
2. Connect terminal B from the master device to terminal B on all slave devices.

3. Connect shielding from ground of master to ground on all slave devices.

**NOTE:** Polarity among units in loop must be observed.

The master device and last (farthest) slave device in the loop must have a termination resistor. This resistor is provided in the Model 300/301 by jumper placement of JP1. The termination jumper JP1 is located under the shield, below the RS-485 terminal block. The jumper JP1 should be in positions 2 and 3 (factory position) for all slave devices except the last (farthest) device in the loop, which should have the jumper in positions 1 and 2.

## TROUBLESHOOTING

### APPLICATION CHECKLIST

Check for the following sensitivities before proceeding to the next section:

- Vapors \_\_\_\_\_
- Mild \_\_\_\_\_ Excessive \_\_\_\_\_
- Foam \_\_\_\_\_
- Surface Agitation \_\_\_\_\_
- Angle of Repose \_\_\_\_\_
- Temperature \_\_\_\_\_
- Pressure \_\_\_\_\_
- Obstructions \_\_\_\_\_

If any of the above sensitivities are present, consult the factory for recommendations.

### INSTALLATION CHECKLIST

#### Cable

1. \_\_\_\_\_ Was Belden 8102 used? If other cable was used, permanent damage may have been done to the transmitter.
2. \_\_\_\_\_ Is transducer wiring run in a dedicated conduit?
3. \_\_\_\_\_ Is transducer shield connected at both ends?

#### Transducer

1. \_\_\_\_\_ Check transducer alignment. Is it vertical?
2. \_\_\_\_\_ Is transducer mounted hand tight? Overtightening may cause ringing, some installations may require using a shock absorber.
3. \_\_\_\_\_ Is minimum nozzle diameter 8 inches?
4. \_\_\_\_\_ Is maximum nozzle height 11 inches?
5. \_\_\_\_\_ Check beam path for obstructions, including tank wall. Refer to page 6 for Ultrasonic Beam Spread.
6. \_\_\_\_\_ Check transducer housing for moisture.

#### Process

1. \_\_\_\_\_ Check for foam.
2. \_\_\_\_\_ Are vapors present? Visible vapors may cause false level reflections, invisible vapors may alter speed of sound.
3. \_\_\_\_\_ Is liquid surface turbulent?
4. \_\_\_\_\_ Does the tank have a mixing blade? Could it be providing false level readings or creating a vortex resulting in echo loss?

#### Transmitter

Enter the specified menu, and obtain the following information before consulting the factory.

#### Measured Values Menu

- Level \_\_\_\_\_
- Temperature \_\_\_\_\_
- Distance \_\_\_\_\_

#### System Configuration

- Range \_\_\_\_\_
- Span \_\_\_\_\_

#### Diagnostics Menu

- Gain \_\_\_\_\_
- Signal Strength \_\_\_\_\_%

#### OTHER INFORMATION

1. Is transmitter indoors or out? \_\_\_\_\_
2. What is the distance from the transducer face to current level? \_\_\_\_\_
3. What is the transmitter's serial number? \_\_\_\_\_
4. What is the temperature?  
a. At transmitter \_\_\_\_\_ b. At transducer \_\_\_\_\_
5. What is the media being measured? \_\_\_\_\_

## TROUBLESHOOTING cont.

Following are troubleshooting displays which could appear on the Model 300/301.

Display	Cause	Solution
FACT PARAM FAIL	The factory parameters dealing with level measurement are corrupt.	Press ENT to continue. This loads the default values for the factory parameters.
TAG LINE LOSS	The tag line characters are corrupt.	Press ENT to continue. This loads the default tag line into long-term memory. If you are using a custom tag line, the tag line must be re-entered.
SYS PARAM FAIL	The main parameters, which store range, span, and communications, etc. are corrupt.	Press ENT to continue. This loads default values for the main parameters. Verify all of the items in the System Config menu.
STRAP TABLE FAIL	There is an error in the custom table (linear or spline) entry.	Press ENT to continue; the table is cleared. If a custom table is not being used, then this error can be ignored. If you are using a custom table, the table has to be re-entered.
FV PARAM FAIL	The flow or volume parameters are corrupt.	Reconfigure flow and volume settings.
LOOP PRESET FAIL	The loop presets are corrupt.	The loop will have to be recalibrated in the Advance Config menu under Adjust Loop Points.
RELAY PARAM FAIL	The parameters for Relays are corrupt.	Press ENT to continue. The relays are disabled, and the settings are set to default values. Reconfigure the relays from the I/O Config menu.
LOOP PARAM FAIL	The 4–20 mA loop parameters are corrupt.	Press ENT to continue. The loop is disabled and the settings are set to default values. Reconfigure the 4-20 mA from the I/O Config menu.
TRANSDUCER FAIL NO TRANSDUCER OR BAD TRANSDUCER	The unit was not able to detect a transducer connected or was not able to determine the transducer's frequency.	Ensure that the transducer is connected properly to the unit. Try replacing the transducer. Return the unit for repair.
ECHO LOSS	The unit is not able to detect a return signal from the transducer.	Ensure that the level to be detected is within the range and span of the unit. Check the application for foam, obstructions, or heavy vapors.
RINGDOWN	The transducer is ringing long enough to ring into the level span of the unit.	Try decreasing the span to increase the dead band (range minus span) of the unit. Try replacing the transducer because the current transducer may have a problem that causes it to ring an extra long time.
TEMPERATURE FAIL	The signal from the temperature transducer in the transducer is out of range. Either a short or open lead detected.	Check to see that the transducer wires are connected properly. Ensure that the transducer wires are not shorted or open.
INVALID PASSWORD	The password entered is not valid.	Retry the previous operation and enter the proper password.
LOOP OUT RANGE	The calculated value for the loop output is greater than 20 mA or less than 4 mA. The loop output will be in its fail-safe mode.	If the level is within a normal operating range, adjust the loop parameters to allow proper tracking of the level.



# SPECIFICATIONS

## TRANSMITTER SPECIFICATIONS

Description	Specification
Supply Voltage	120 Vac +10%/-15%, 50-60 Hz 240 Vac +10%/-15%, 50-60 Hz 24 Vdc +/-20%
Power Consumption	12 watts maximum
Analog output signal Active mode	4-20 mA (isolated) maximum 1,000 Ω loop resistance
Analog output signal Passive mode	4-20 mA (isolated) loop resistance dependent on power supply
Digital output	RS-485 with Modbus
Relays	10 amp SPDT resistive (none, 2, or 4)
Fail-safe	User selectable for analog and relay outputs
Ambient Temperature (Electronics)	-40° F to +160° F (-40° C to +71° C)
Display	Two-line alphanumeric LCD (16 characters per line)
Keypad	16-button
Humidity (Electronics)	99% non-condensing
Fuse (Non-replaceable)	¾ amp, 250 Vac Slo-Blo® for AC units 1½ amp, 250 Vdc Slo-Blo® for DC units

## PERFORMANCE SPECIFICATIONS

Description	Specification
Response time	2 seconds typical
Accuracy	± 0.25% of calibrated span

These units have been tested to EN 50081-2 and EN 50082-2 and are in compliance with the EMC Directive 89/336/EEC.



## DIMENSIONAL SPECIFICATIONS Inches (mm)

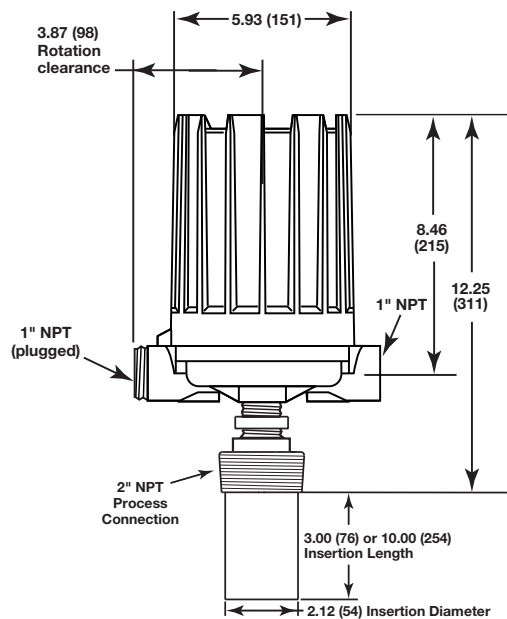

**Model 300 Integral Mount**

## TRANSDUCER SPECIFICATIONS

Description	Specification
Transducer Frequency	38 kHz
Maximum Range	30 feet (9.1 m)
Maximum Span	28.5 feet (8.7 m)
Dead Band	18 inches (460 mm) minimum
Ambient Temperature (Transducer)	-40° F to +163° F (-40° C to +73° C) non-operational to +250° F (121° C)
Temperature Compensation	Automatic over range of transducer operating temperature
Operating Pressure	-10 to +50 psig (-0.689 to +3.45 Bar)
Beam Angle	Conical 12°
Cable length	500 feet maximum (between transducer and electronics)

## FM AGENCY APPROVALS

Model	Approval
300-RXXX-45X, 301-RXXX-400 and 384-XKXX-0XX	Indoors and outdoors NEMA Type 4X and IP 65  Hazardous locations Class I, Division 1, Groups B, C, & D Class II, Division 1, Groups E, F, & G Class III

## CSA AGENCY APPROVALS

Model	Approval
300-RXXX-45X, 301-RXXX-400 and 384-XK0X-0XX	Non-hazardous environment Type 4X enclosure  Hazardous environments Class I, Division 1, Groups B, C, & D Class II, Division 1, Groups E, F, & G Class III
384-XK1X-0XX and 384-XKYX-0XX	Hazardous environments Class I, Division 1, Groups C & D Class II, Division 1, Groups E, F, & G Class III

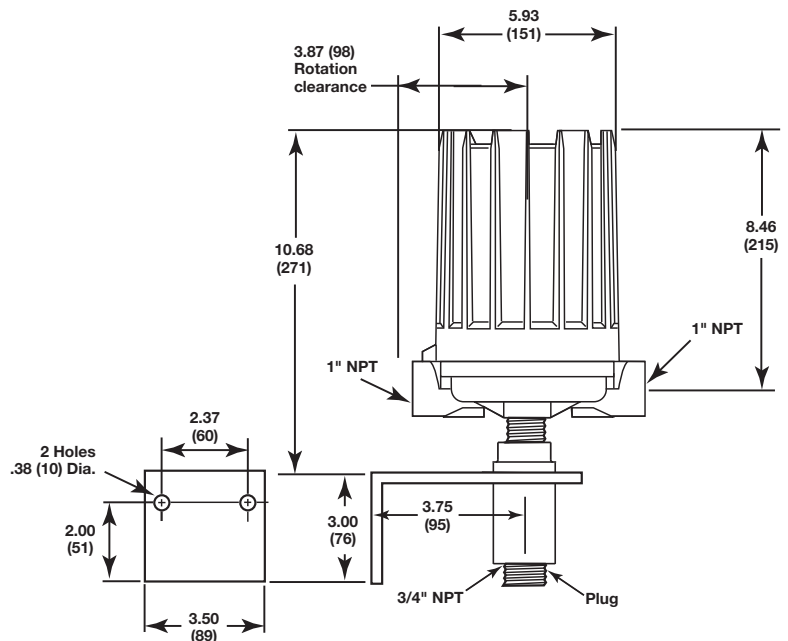

**Model 301 Remote Mount with Bracket**

**Figure 21  
Transmitters**

# SPECIFICATIONS cont.

## DIMENSIONAL SPECIFICATIONS Inches (mm)

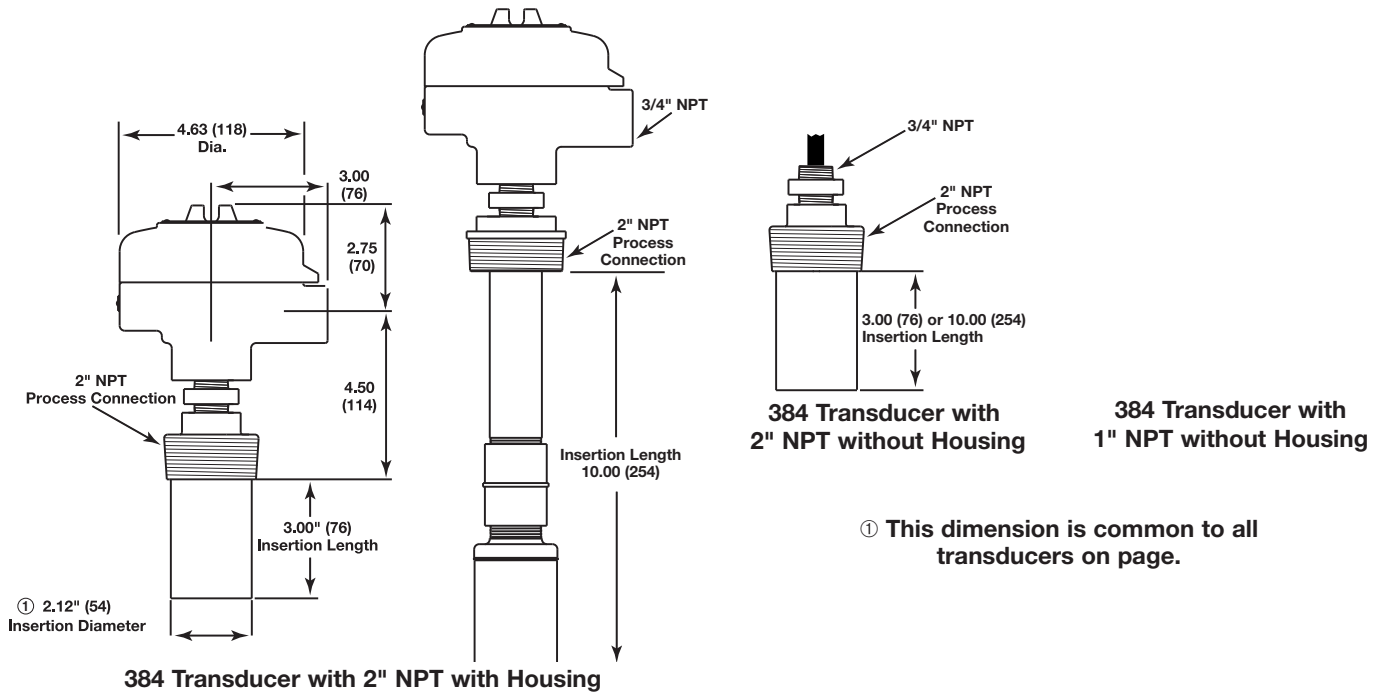

Figure 22  
Transducers

## REPLACEMENT PARTS

Item	Description		Part Number
1	Cover		004-9174-007
2	Base		004-9188-004
3	O-Ring		012-2201-253
4	Daughter board		030-3559-001
5	Logic board	4-20	030-2225-001
		RS-485	030-2225-002
		4-20/RS-485	030-2225-003
6	120 VAC	0 relays	030-2212-003
		2 relays	030-2212-002
		4 relays	030-2212-001
	240 VAC	0 relays	030-2212-006
		2 relays	030-2212-005
		4 relays	030-2212-004
	24 VDC	0 relays	030-2212-009
		2 relays	030-2212-008
		4 relays	030-2212-007
7	Termination board		030-3515-001
8	Transducer housing base	Aluminum	004-9104-001
		316 SS	004-9140-001
9	Transducer housing cover	Aluminum	004-9105-001
		316 SS	004-9142-001
10	Transducer housing O-ring		012-2101-345
11	Transducer (Refer to Model Identification on page 2.		

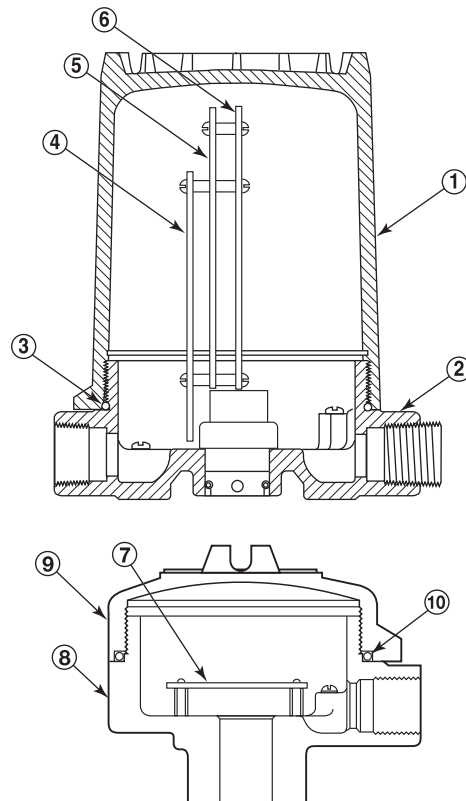

Figure 23  
Replacement Parts

# IMPORTANT

## PRODUCT WARRANTY

All Magnetrol electronic and ultrasonic level and flow controls are warranted free of defects in materials or workmanship for one full year from the date of original factory shipment.

If returned within the warranty period; and, upon factory inspection of the control, the cause of the claim is determined to be covered under the warranty; then, Magnetrol will repair or replace the control at no cost to the purchaser (or owner) other than transportation.

Magnetrol shall not be liable for misapplication, labor claims, direct or consequential damage or expense arising from the installation or use of equipment. There are no other warranties expressed or implied, except special written warranties covering some Magnetrol products.

## QUALITY ASSURANCE

The quality assurance system in place at Magnetrol guarantees the highest level of quality throughout the company. Magnetrol is committed to providing full customer satisfaction both in quality products and quality service.



The Magnetrol quality assurance system is registered to ISO 9001 affirming its commitment to known international quality standards providing the strongest assurance of product/service quality available.

## ASSURED QUALITY & SERVICE COST LESS

### SERVICE POLICY

Owners of Magnetrol may request the return of a control or any part of a control for complete rebuilding or replacement. They will be rebuilt or replaced promptly. Controls returned under our service policy must be returned by Prepaid transportation. Magnetrol will repair or replace the control at no cost to the purchaser (or owner) other than transportation if:

1. Returned within the warranty period; and
2. The factory inspection finds the cause of the claim to be covered under the warranty.

If the trouble is the result of conditions beyond our control; or, is NOT covered by the warranty, there will be charges for labor and the parts required to rebuild or replace the equipment.

In some cases it may be expedient to ship replacement parts; or, in extreme cases a complete new control, to replace the original equipment before it is returned. If this is desired, notify the factory of both the model and serial numbers of the control to be replaced. In such cases, credit for the materials returned will be determined on the basis of the applicability of our warranty.

No claims for misapplication, labor, direct or consequential damage will be allowed.

### RETURN MATERIAL PROCEDURE

So that we may efficiently process any materials that are returned, it is essential that a "Return Material Authorization" (RMA) number be obtained from the factory, prior to the material's return. This is available through a Magnetrol local representative or by contacting the factory. Please supply the following information:

1. Company Name
2. Description of Material
3. Serial Number
4. Reason for Return
5. Application

Any unit that was used in a process must be properly cleaned in accordance with OSHA standards, before it is returned to the factory.

A Material Safety Data Sheet (MSDS) must accompany material that was used in any media.

All shipments returned to the factory must be by prepaid transportation.

All replacements will be shipped F.O.B. factory.

**NOTE:** See Electrostatic Discharge Handling Procedure on page 6.



5300 Belmont Road • Downers Grove, Illinois 60515-4499 • 630-969-4000 • Fax 630-969-9489 • www.magnetrol.com  
145 Jardin Drive, Units 1 & 2 • Concord, Ontario Canada L4K 1X7 • 905-738-9600 • Fax 905-738-1306  
Heikensstraat 6 • B 9240 Zele, Belgium • 052 45.11.11 • Fax 052 45.09.93  
Regent Business Ctr., Jubilee Rd. • Burgess Hill, Sussex RH15 9TL U.K. • 01444-871313 • Fax 01444-871317

Copyright © 2011 Magnetrol International, Incorporated. All rights reserved. Printed in the USA.

**BULLETIN: 51-624.1**  
**EFFECTIVE: March 2011**  
**SUPERSEDES: June 1999**