



LOC		DIST		REVISIONS			
A	66	P	LTM	DESCRIPTION	DATE	OWN	APVD
		-	-	SEE SHEET 1			

### FEED TYPE MECHANICAL



### PNEUMATIC

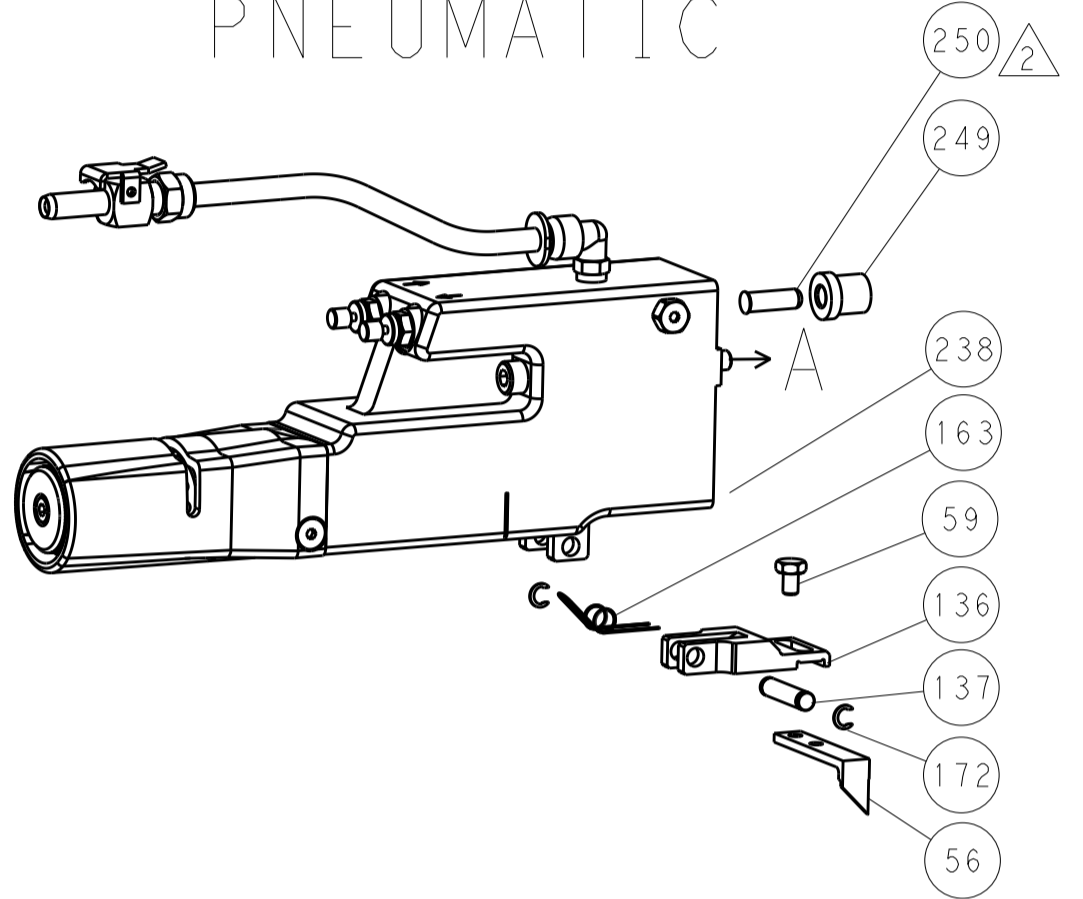

### SERVO LATCH PLATE



### CAM POSITIONS

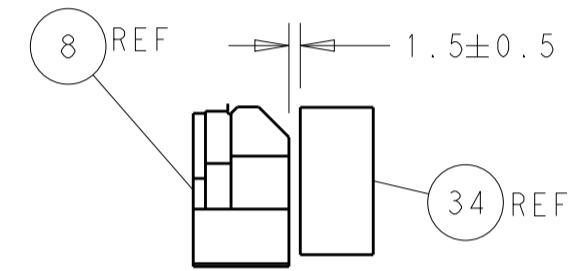
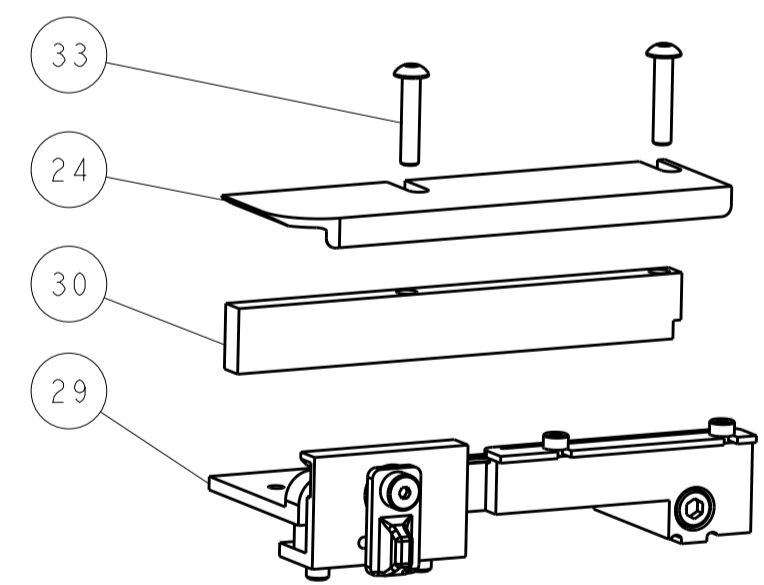
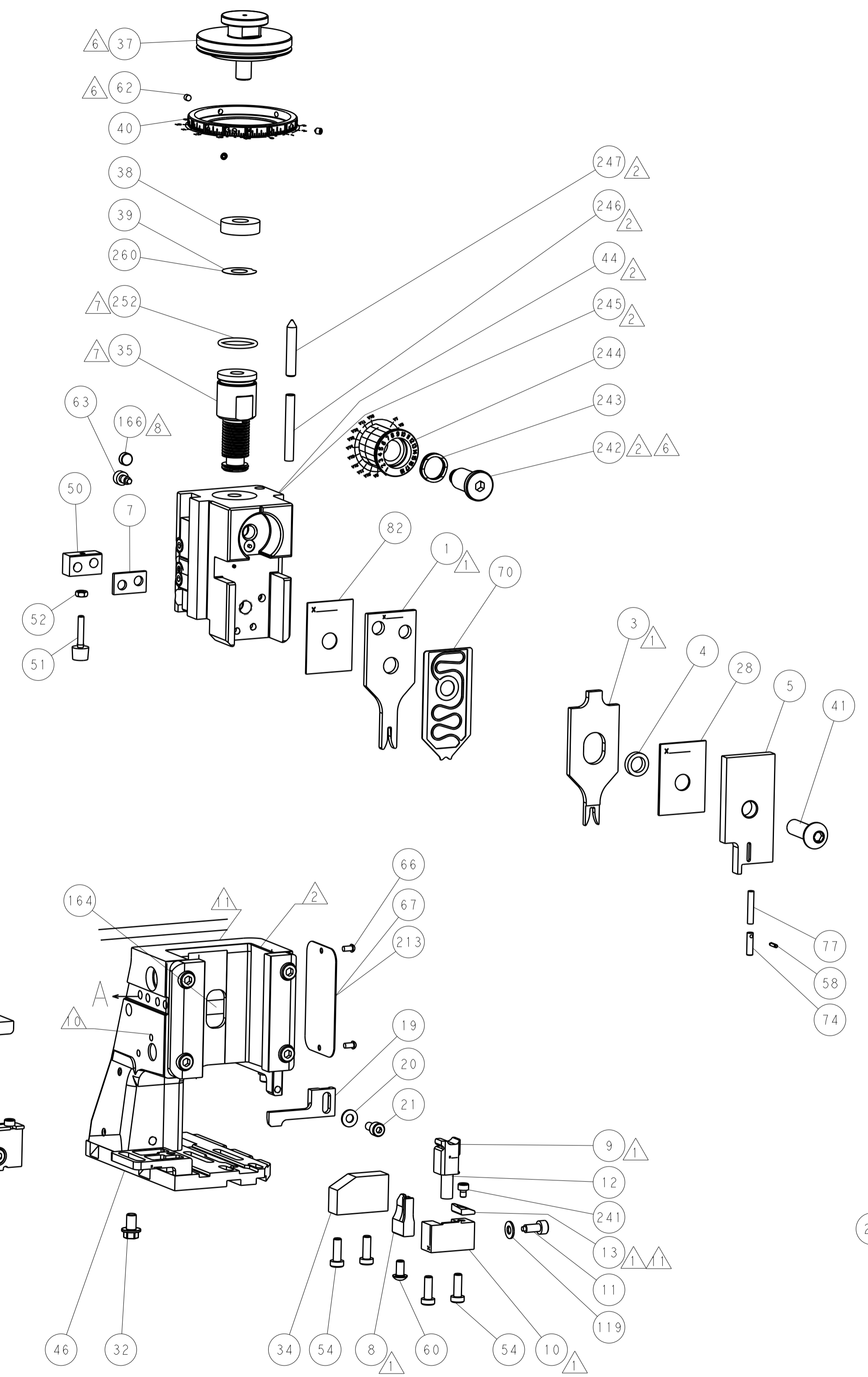

TERMINAL SUPPORT LOCATION

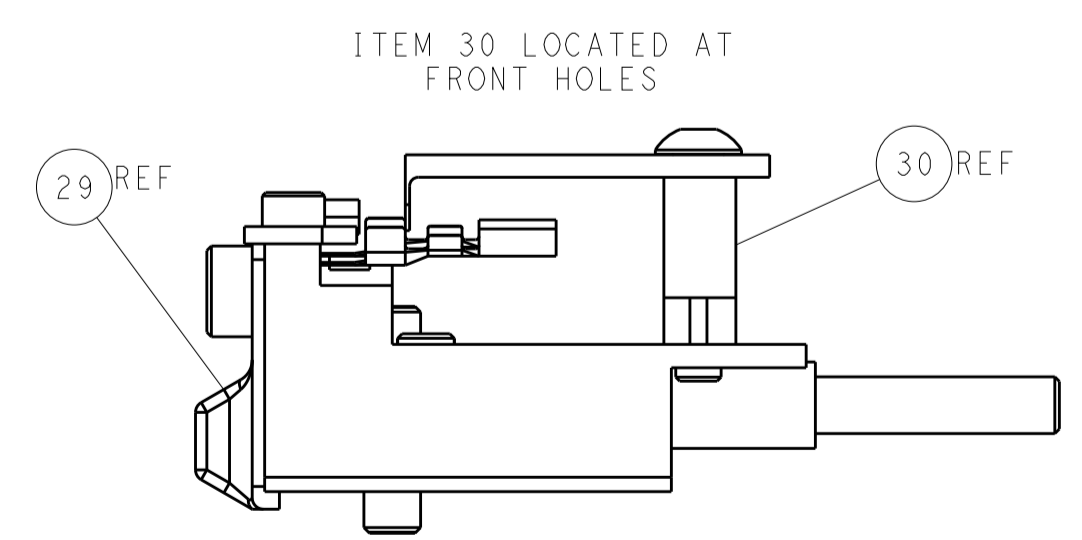

FEED TRACK POSITION GUIDE BY INSULATION BARREL

**ATLANTIC VERSION**  
 Shown on sheets 1 of 4 & 2 of 4  
 (Pacific version shown on sheets 3 of 4 & 4 of 4)

DIMENSIONS:		TOLERANCES UNLESS OTHERWISE SPECIFIED:		DWN R. HUANG 31AUG2012		TE Connectivity Harrisburg, PA 17105-3608	
mm	0 PLC	±		CHK S. XI 31AUG2012	NAME	Ocean Side Feed Applicator	
	1 PLC	±		APVD S. XI 31AUG2012	PRODUCT SPEC	RESTRICTED TO	
	2 PLC	±			APPLICATION SPEC	SIZE CAGE CODE DRAWING NO	
	3 PLC	±			ANGLES	A1 00779 ©=2151744	
	4 PLC	±			WEIGHT	Customer Accessible Production Drawing	
MATERIAL	FINISH				SCALE	1:2 SHEET 2 OF 4 REV E1	



LOC		DIST		REVISIONS			
A	66	P	LTM	DESCRIPTION	DATE	OWN	APVD
		-		SEE SHEET 1			

# FEED TYPE MECHANICAL



# PNEUMATIC



# SERVO LATCH PLATE



# CAM POSITIONS

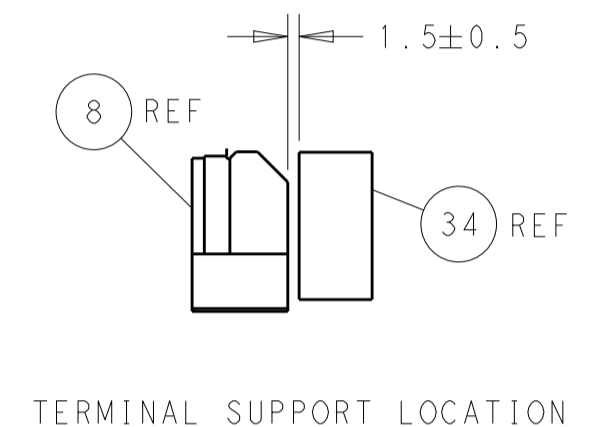
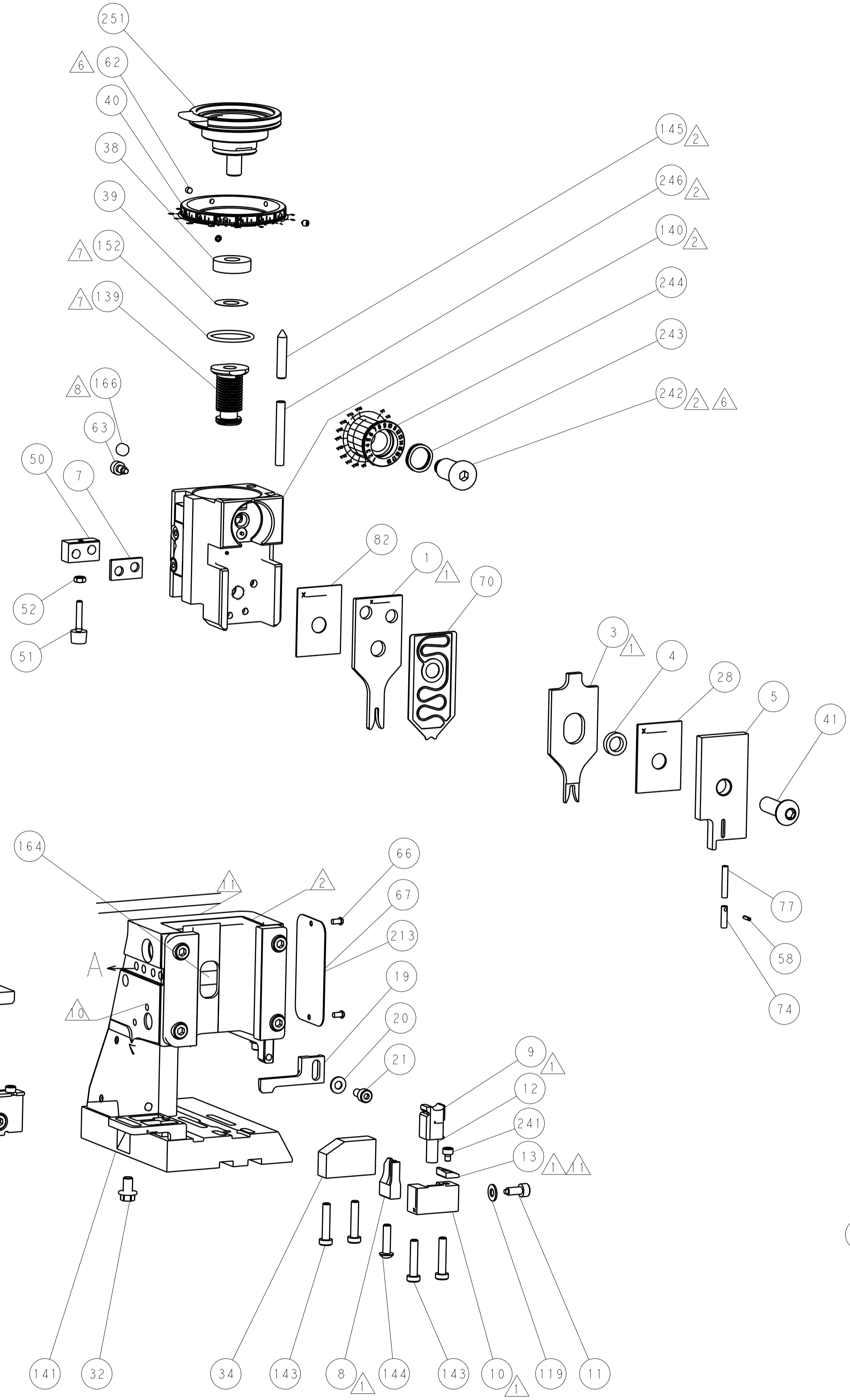

TERMINAL SUPPORT LOCATION

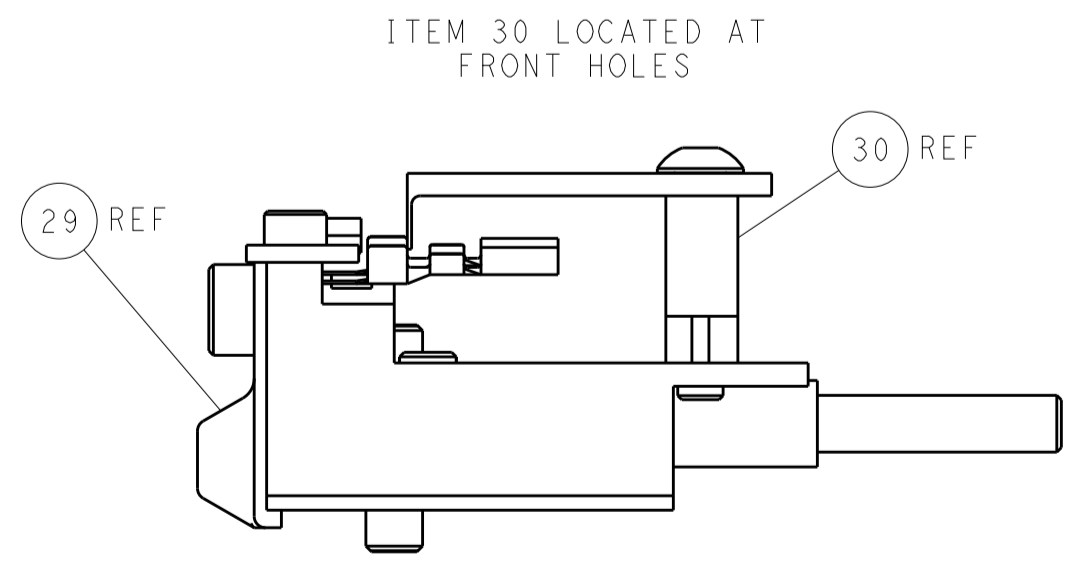

FEED TRACK POSITION GUIDE BY INSULATION BARREL

**PACIFIC VERSION**  
 Shown on sheets 3 of 4 & 4 of 4  
 (Atlantic version shown on sheets 1 of 4 & 2 of 4)

DIMENSIONS:		TOLERANCES UNLESS OTHERWISE SPECIFIED:		DWN R. HUANG 31AUG2012		STE TE Connectivity Harrisburg, PA 17105-3608	
mm	0 PLC	±		CHK S. XI 31AUG2012	NAME	Ocean Side Feed Applicator	
	1 PLC	±		APVD S. XI 31AUG2012	PRODUCT SPEC	RESTRICTED TO	
	2 PLC	±			APPLICATION SPEC	SIZE CAGE CODE DRAWING NO	
	3 PLC	±				A1 00779 ©=2151744	
	4 PLC	±			WEIGHT	SCALE 1:2 SHEET 4 OF 4 REV E1	
	ANGLES	±			MATERIAL	Customer Accessible Production Drawing	