

## OPA2333P 1.8-V, *micro*Power, CMOS Operational Amplifier, Zero-Drift

### 1 Features

- Low Offset Voltage: 10  $\mu\text{V}$  (Maximum)
- Zero Drift: 0.05  $\mu\text{V}/^\circ\text{C}$  (Maximum)
- 0.01-Hz to 10-Hz Noise: 1.1  $\mu\text{V}_{\text{PP}}$
- Quiescent Current: 17  $\mu\text{A}$
- Single-Supply Operation
- Supply Voltage: 1.8 V to 5.5 V
- Rail-to-Rail Input/Output
- Specified start-up time: 500  $\mu\text{s}$  (Maximum)
- *micro*Size Package: 2-mm  $\times$  2-mm WSON

### 2 Applications

- Smartphones
- Wearables
- Fitness and Healthcare Products
- Electronic Scales
- Medical Instrumentation
- Battery-Powered Instruments
- Handheld Test Equipment

### 3 Description

The OPA2333P is a CMOS operational amplifier that uses a proprietary auto-calibration technique to simultaneously provide very low offset voltage (10  $\mu\text{V}$ , maximum) and near-zero drift over time and temperature. This miniature, high-precision, low quiescent current amplifier offers high-impedance inputs that have a common-mode range 100 mV beyond the rails, and rail-to-rail output that swings within 50 mV of the rails. Single or dual supplies as low as 1.8 V ( $\pm 0.9$  V) and up to 5.5 V ( $\pm 2.75$  V) can be used. This device is optimized for low-voltage, single-supply operation.

The OPA2333P offers excellent CMRR without the crossover associated with traditional complementary input stages. This design results in superior performance for driving analog-to-digital converters (ADCs) without degradation of differential linearity.

The OPA2333P is available in a 2-mm  $\times$  2-mm 8-pin WSON package and is specified for operation from  $-40^\circ\text{C}$  to  $125^\circ\text{C}$ .

#### Device Information<sup>(1)</sup>

PART NUMBER	PACKAGE	BODY SIZE (NOM)
OPA2333P	WSON (8)	2.00 mm $\times$ 2.00 mm

(1) For all available packages, see the orderable addendum at the end of the data sheet.

#### Bidirectional, Low-Side Current Shunt Amplifier

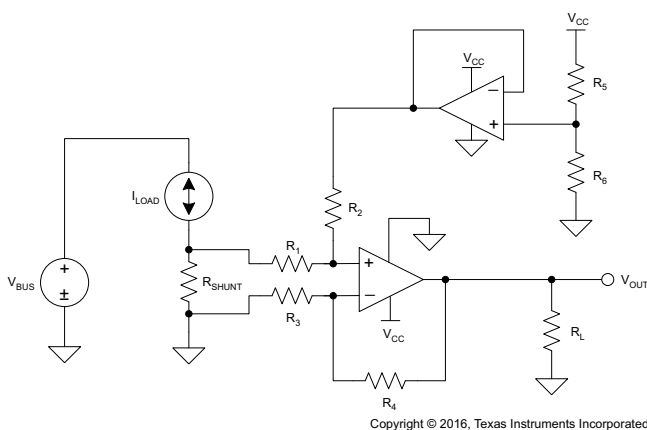

#### 0.1-Hz to 10-Hz Noise

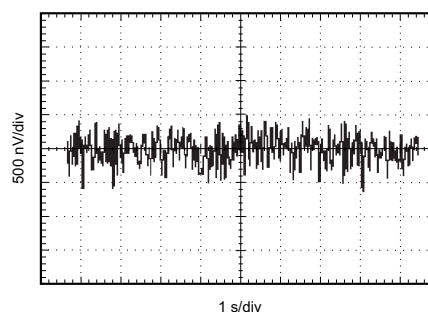

## Table of Contents

<b>1 Features</b> .....	<b>1</b>	<b>8 Application and Implementation</b> .....	<b>15</b>
<b>2 Applications</b> .....	<b>1</b>	8.1 Application Information.....	15
<b>3 Description</b> .....	<b>1</b>	8.2 Typical Application .....	15
<b>4 Revision History</b> .....	<b>2</b>	<b>9 Power Supply Recommendations</b> .....	<b>20</b>
<b>5 Pin Configuration and Functions</b> .....	<b>3</b>	<b>10 Layout</b> .....	<b>21</b>
<b>6 Specifications</b> .....	<b>4</b>	10.1 Layout Guidelines .....	21
6.1 Absolute Maximum Ratings .....	4	10.2 Layout Example .....	21
6.2 ESD Ratings.....	4	<b>11 Device and Documentation Support</b> .....	<b>22</b>
6.3 Recommended Operating Conditions .....	4	11.1 Device Support.....	22
6.4 Thermal Information: OPA2333P.....	4	11.2 Documentation Support .....	22
6.5 Electrical Characteristics.....	5	11.3 Receiving Notification of Documentation Updates	22
6.6 Typical Characteristics .....	7	11.4 Community Resources.....	22
<b>7 Detailed Description</b> .....	<b>11</b>	11.5 Trademarks .....	22
7.1 Overview .....	11	11.6 Electrostatic Discharge Caution.....	22
7.2 Functional Block Diagram .....	11	11.7 Glossary .....	22
7.3 Feature Description.....	11	<b>12 Mechanical, Packaging, and Orderable</b>	
7.4 Device Functional Modes.....	14	<b>Information</b> .....	<b>23</b>

## 4 Revision History

NOTE: Page numbers for previous revisions may differ from page numbers in the current version.

DATE	REVISION	NOTES
November 2017	*	Initial release

## 5 Pin Configuration and Functions

**DFN Package  
8-Pin WSON With Exposed Thermal Pad  
Top View**

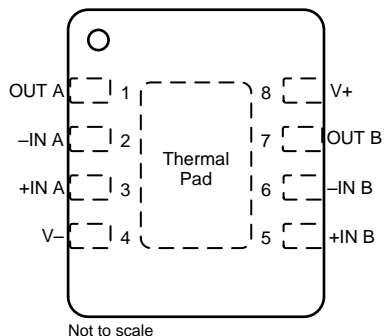

### Pin Functions

PIN		I/O	DESCRIPTION
NAME	NO.		
+IN A	3	I	Noninverting input, channel A
+IN B	5	I	Noninverting input, channel B
-IN A	2	I	Inverting input, channel A
-IN B	6	I	Inverting input, channel B
OUT A	1	O	Output, channel A
OUT B	7	O	Output, channel B
V+	8	—	Positive (highest) power supply
V-	4	—	Negative (lowest) power supply
Thermal Pad	—	—	Thermal Pad, Connect to V-

## 6 Specifications

### 6.1 Absolute Maximum Ratings

over operating free-air temperature range (unless otherwise noted)<sup>(1)</sup>

		MIN	MAX	UNIT
Supply voltage, $V_S = (V+) - (V-)$	Single-supply		7	V
	Dual-supply		±3.5	
Signal input pins	Voltage	Common-mode <sup>(2)</sup>	(V-) – 0.3 (V+) + 0.3	
		Differential <sup>(2)</sup>	±0.5	
	Current <sup>(3)</sup>		±1	mA
Output short current <sup>(4)</sup>		Continuous		
Temperature	Operating, $T_A$	–40	150	°C
	Junction, $T_J$		150	
	Storage, $T_{stg}$	–65	150	

- (1) Stresses beyond those listed under *Absolute Maximum Rating* may cause permanent damage to the device. These are stress ratings only, which do not imply functional operation of the device at these or any other conditions beyond those indicated under *Recommended Operating Conditions*. Exposure to absolute-maximum-rated conditions for extended periods may affect device reliability.
- (2) Input terminals are anti-parallel diode-clamped to each other. Input signals that can cause differential voltages of swing more than ±0.5 V must be current-limited to 10 mA or less.
- (3) Input terminals are diode-clamped to the power-supply rails. Input signals that can swing more than 0.5 V beyond the supply rails should be current-limited to 10 mA or less.
- (4) Short-circuit to ground, one amplifier per package.

### 6.2 ESD Ratings

		VALUE	UNIT
$V_{(ESD)}$ Electrostatic discharge	Human body model (HBM), per ANSI/ESDA/JEDEC JS-001, all pins <sup>(1)</sup>	±4000	V
	Charged device model (CDM), per JEDEC specification JESD22-C101, all pins <sup>(2)</sup>	±1000	

- (1) JEDEC document JEP155 states that 500-V HBM allows safe manufacturing with a standard ESD control process.
- (2) JEDEC document JEP157 states that 250-V CDM allows safe manufacturing with a standard ESD control process.

### 6.3 Recommended Operating Conditions

over operating free-air temperature range (unless otherwise noted)

		MIN	NOM	MAX	UNIT
$V_S$ Supply voltage, [(V+) - (V-)]	Single supply	1.8		5.5	V
	Dual supply	±0.9		±2.75	
Specified temperature		–40		125	°C

### 6.4 Thermal Information: OPA2333P

THERMAL METRIC <sup>(1)</sup>		OPA2333P	UNIT
		DSG (WSON)	
		8 PINS	
$R_{\theta JA}$	Junction-to-ambient thermal resistance	74.5	°C/W
$R_{\theta JC(top)}$	Junction-to-case (top) thermal resistance	93.5	°C/W
$R_{\theta JB}$	Junction-to-board thermal resistance	41.1	°C/W
$\Psi_{JT}$	Junction-to-top characterization parameter	4.3	°C/W
$\Psi_{JB}$	Junction-to-board characterization parameter	41.2	°C/W
$R_{\theta JC(bot)}$	Junction-to-case (bottom) thermal resistance	15.7	°C/W

- (1) For more information about traditional and new thermal metrics, see the *Semiconductor and IC Package Thermal Metrics* application report.

## 6.5 Electrical Characteristics

over operating free-air temperature range (unless otherwise noted)

PARAMETER		TEST CONDITIONS		MIN	TYP	MAX	UNIT
<b>OFFSET VOLTAGE</b>							
$V_{OS}$	Input offset voltage	$V_S = 5\text{ V}$				$\pm 2$	$\mu\text{V}$
		$V_S = 5\text{ V}$	$T_A = -40^\circ\text{C to } +125^\circ\text{C}$			$\pm 10$	$\mu\text{V}$
$dV_{OS}/dT$	Input offset voltage drift	$V_S = 5\text{ V}$	$T_A = -40^\circ\text{C to } +125^\circ\text{C}$			$\pm 0.05$	$\mu\text{V}/^\circ\text{C}$
PSRR	Power-supply rejection ratio	$1.8\text{ V} \leq V_S \leq 5.5\text{ V}$	$T_A = -40^\circ\text{C to } +125^\circ\text{C}$		1	5	$\mu\text{V}/\text{V}$
	Channel separation, dc				0.1		$\mu\text{V}/\text{V}$
<b>INPUT BIAS CURRENT</b>							
$I_B$	Input bias current	$T_A = 25^\circ\text{C}$			$\pm 70$	$\pm 200$	$\text{pA}$
		$T_A = -40^\circ\text{C to } +125^\circ\text{C}$			$\pm 150$	$\pm 400$	$\text{pA}$
$I_{OS}$	Input offset current				$\pm 140$	$\pm 400$	$\text{pA}$
<b>NOISE</b>							
$E_N$	Input voltage noise	$f = 0.1\text{ Hz to } 10\text{ Hz, peak-to-peak}$			1.1		$\mu\text{V}_{PP}$
		$f = 0.1\text{ Hz to } 10\text{ Hz, RMS}$			0.2		$\mu\text{V}_{RMS}$
$e_N$	Input voltage noise density	$f = 10\text{ Hz}$			55		$\text{nV}/\sqrt{\text{Hz}}$
		$f = 1\text{ kHz}$			55		$\text{nV}/\sqrt{\text{Hz}}$
$i_N$	Input current noise density	$f = 100\text{ Hz}$			100		$\text{fA}/\sqrt{\text{Hz}}$
<b>INPUT VOLTAGE</b>							
$V_{CM}$	Common-mode voltage range			$(V_-) - 0.1$		$(V_+) + 0.1$	$\text{V}$
CMRR	Common-mode rejection ratio	$(V_-) - 0.1\text{ V} \leq V_{CM} \leq (V_+) + 0.1\text{ V}$	$T_A = -40^\circ\text{C to } +125^\circ\text{C}$	106	130		$\text{dB}$
<b>INPUT IMPEDANCE</b>							
$Z_{ID}$	Differential				$10^{13} \parallel 2$		$\Omega \parallel \text{pF}$
$Z_{ICM}$	Common-mode				$10^{13} \parallel 4$		$\Omega \parallel \text{pF}$
<b>OPEN-LOOP GAIN</b>							
$A_{OL}$	Open-loop voltage gain	$T_A = -40^\circ\text{C to } +125^\circ\text{C}$	$(V_-) + 100\text{ mV} \leq V_O \leq (V_+) - 100\text{ mV, } R_L = 10\text{ k}\Omega$	106	130		$\text{dB}$
			$(V_-) + 100\text{ mV} \leq V_O \leq (V_+) - 100\text{ mV, } R_L = 2\text{ k}\Omega$		130		$\text{dB}$

**Electrical Characteristics (continued)**

over operating free-air temperature range (unless otherwise noted)

PARAMETER		TEST CONDITIONS		MIN	TYP	MAX	UNIT
<b>FREQUENCY RESPONSE</b>							
$\phi_m$	Phase margin	$V_O = 10\text{ mV}_{PP}, C_L = 100\text{ pF}$			65		Degrees
GBW	Gain-bandwidth product	$V_O = 10\text{ mV}_{PP}, C_L = 100\text{ pF}$			350		kHz
SR	Slew rate	$V_O = 4\text{-V step}$	$G = 1$		0.16		V/ $\mu\text{s}$
<b>OUTPUT</b>							
Output voltage swing		$R_L = 10\text{ k}\Omega$			30	50	mV
		$R_L = 2\text{ k}\Omega$			50	100	mV
		$T_A = -40^\circ\text{C to } +125^\circ\text{C}$	$R_L = 10\text{ k}\Omega$			70	mV
			$R_L = 2\text{ k}\Omega$			150	mV
$I_{SC}$	Short-circuit current				$\pm 5$		mA
$C_L$	Capactive load drive			See <i>Typical Characteristics</i>			
$Z_O$	Open-loop output impedance	$f = 350\text{ kHz}, I_O = 0\text{ mA}$			2		k $\Omega$
	Turnon time	$V_S = 5\text{ V}$			100	500	$\mu\text{s}$
<b>POWER SUPPLY</b>							
$V_S$	Specified voltage			1.8		5.5	V
$I_Q$	Quiescent current (per amplifier)	$I_O = 0\text{ A}$			17	25	$\mu\text{A}$
			$T_A = -40^\circ\text{C to } +125^\circ\text{C}$			28	
<b>TEMPERATURE RANGE</b>							
$T_A$	Specified range			-40		125	$^\circ\text{C}$
$T_A$	Operating range			-55		150	$^\circ\text{C}$

## 6.6 Typical Characteristics

Table 1. List of Typical Characteristics

TITLE	FIGURE
Offset Voltage Production Distribution	Figure 1
Offset Voltage Drift Production Distribution	Figure 2
Open-Loop Gain vs Frequency	Figure 3
Common-Mode Rejection Ratio vs Frequency	Figure 4
Power-Supply Rejection Ratio vs Frequency	Figure 5
Output Voltage Swing vs Output Current	Figure 6
Input Bias Current vs Common-Mode Voltage	Figure 7
Input Bias Current vs Temperature	Figure 8
Quiescent Current vs Temperature	Figure 9
Large-Signal Step Response	Figure 10
Small-Signal Step Response	Figure 11
Positive Overvoltage Recovery	Figure 12
Negative Overvoltage Recovery	Figure 13
Settling Time vs Closed-Loop Gain	Figure 14
Small-Signal Overshoot vs Load Capacitance	Figure 15
0.1-Hz to 10-Hz Noise	Figure 16
Current and Voltage Noise Spectral Density vs Frequency	Figure 17

At  $T_A = 25^\circ\text{C}$ ,  $V_S = 5\text{ V}$ , and  $C_L = 0\text{ pF}$ , unless otherwise noted.

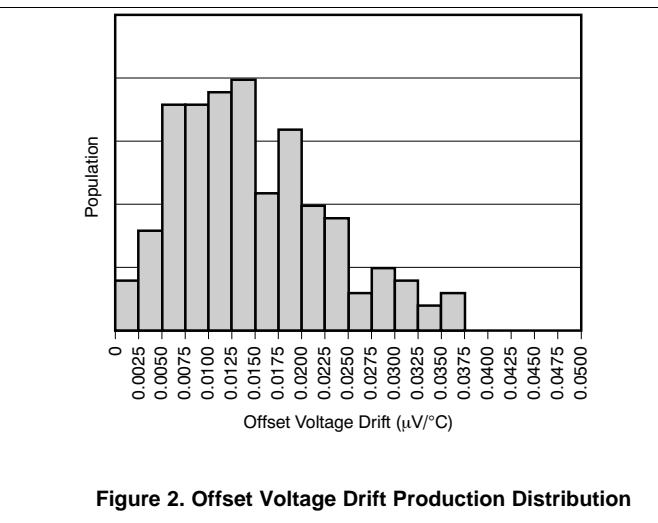
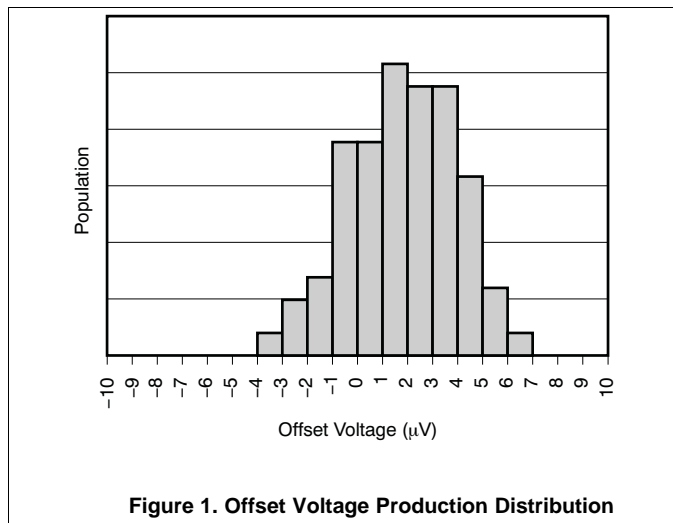

At  $T_A = 25^\circ\text{C}$ ,  $V_S = 5\text{ V}$ , and  $C_L = 0\text{ pF}$ , unless otherwise noted.

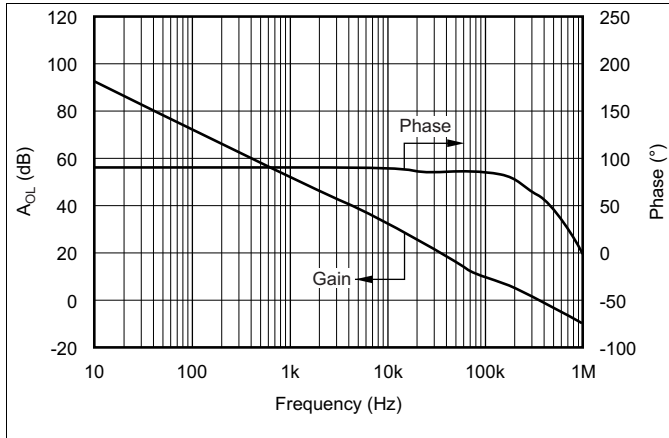

Figure 3. Open-Loop Gain and Phase vs Frequency

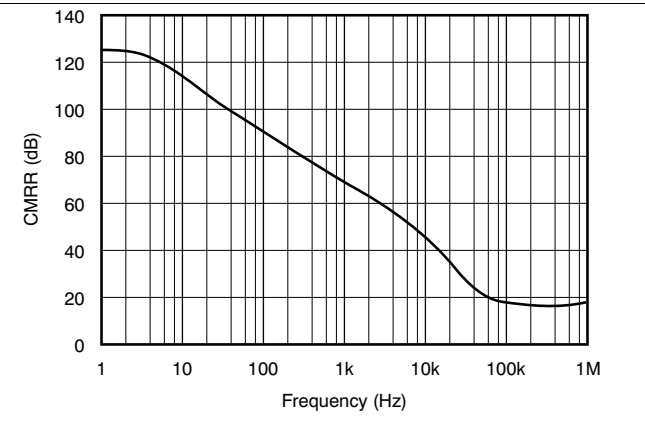

Figure 4. Common-Mode Rejection Ratio vs Frequency

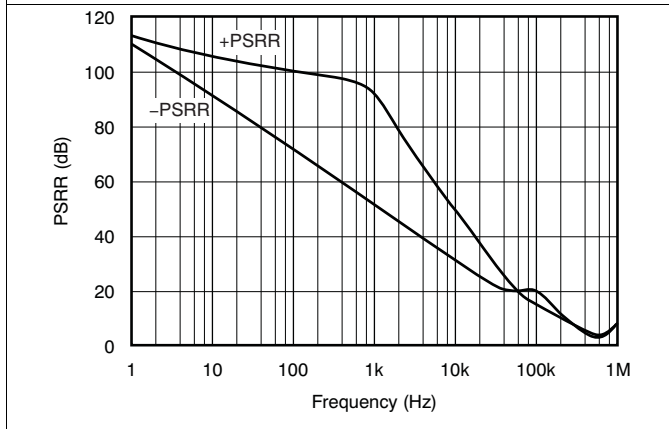

Figure 5. Power-Supply Rejection Ratio vs Frequency

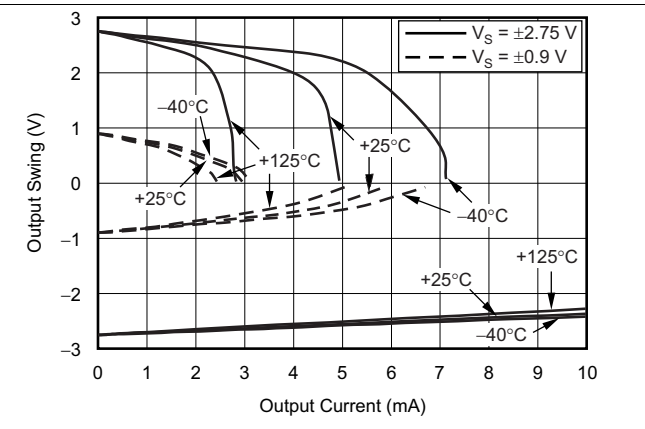

Figure 6. Output Voltage Swing vs Output Current

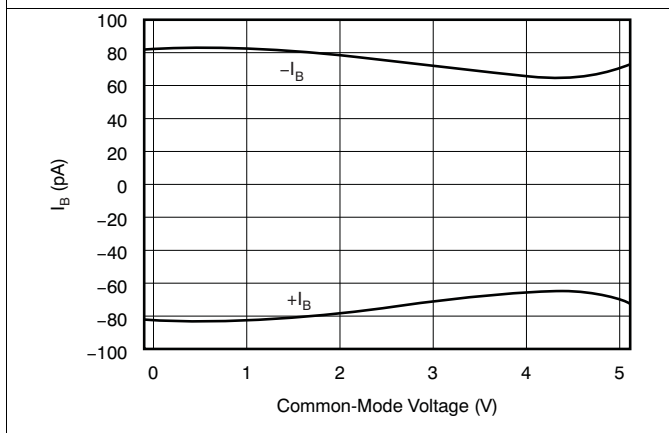

Figure 7. Input Bias Current vs Common-Mode Voltage

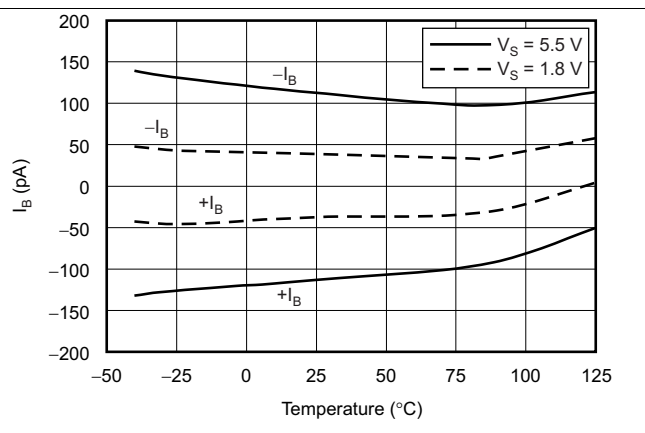

Figure 8. Input Bias Current vs Temperature

At  $T_A = 25^\circ\text{C}$ ,  $V_S = 5\text{ V}$ , and  $C_L = 0\text{ pF}$ , unless otherwise noted.

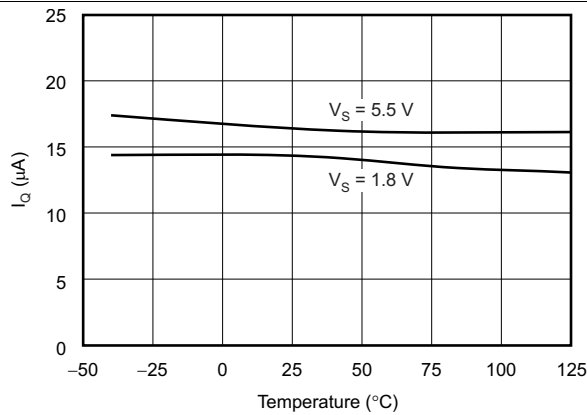

Figure 9. Quiescent Current vs Temperature

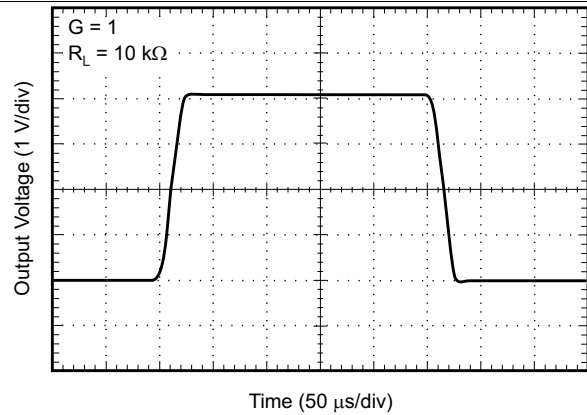

Figure 10. Large-Signal Step Response

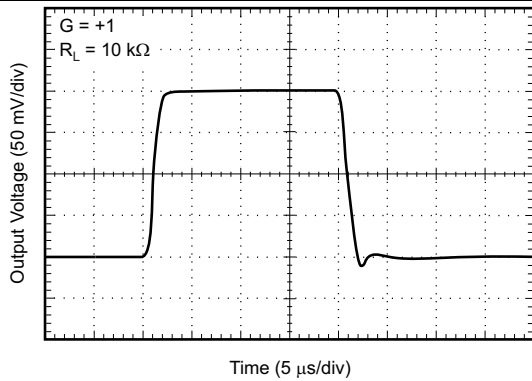

Figure 11. Small-Signal Step Response

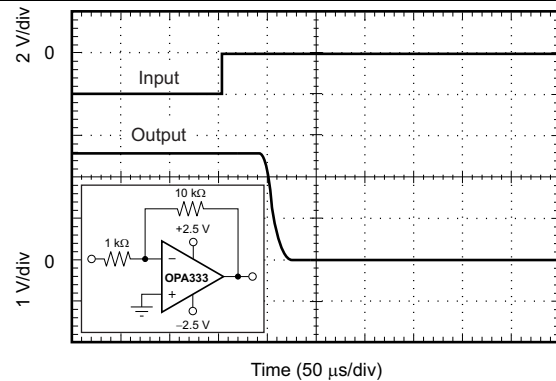

Figure 12. Positive Overvoltage Recovery

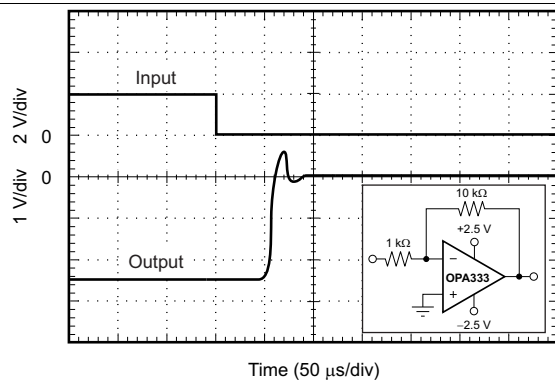

Figure 13. Negative Overvoltage Recovery

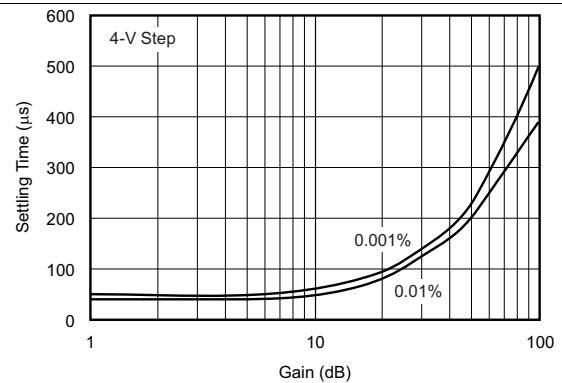
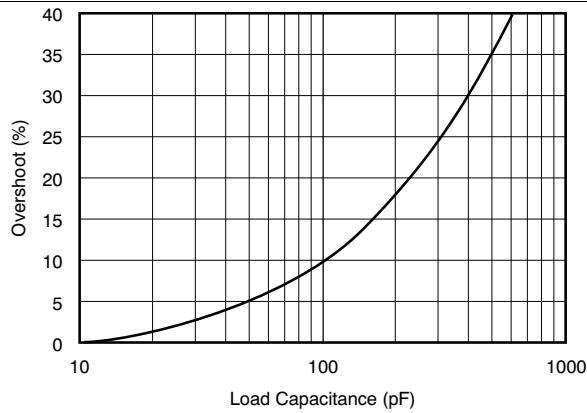
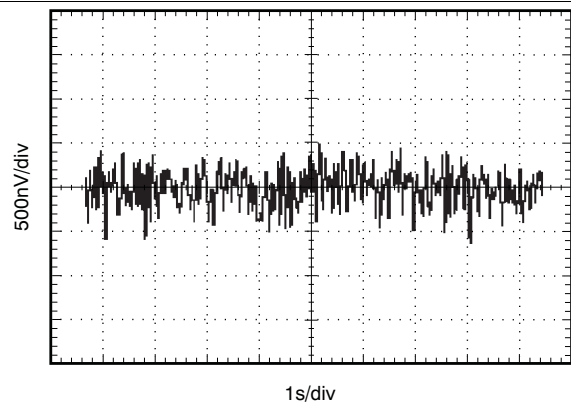

Figure 14. Settling Time vs Closed-Loop Gain

At  $T_A = 25^\circ\text{C}$ ,  $V_S = 5\text{ V}$ , and  $C_L = 0\text{ pF}$ , unless otherwise noted.



**Figure 15. Small-Signal Overshoot vs Load Capacitance**



**Figure 16. 0.1-Hz to 10-Hz Noise**

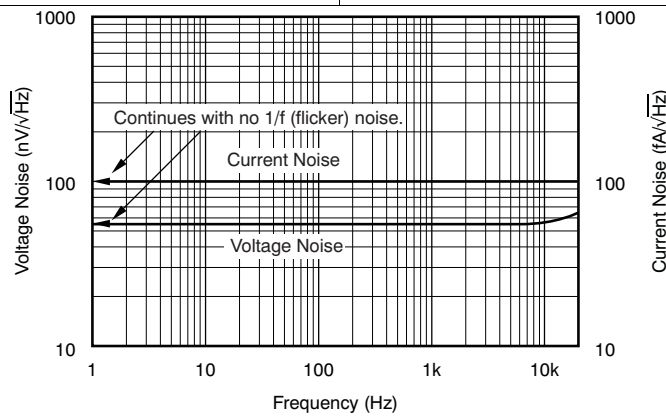

**Figure 17. Current and Voltage Noise Spectral Density vs Frequency**

## 7 Detailed Description

### 7.1 Overview

The OPA2333P is a Zero-Drift, low-power, rail-to-rail input and output operational amplifier. The device operates from 1.8 V to 5.5 V, is unity-gain stable, and is suitable for a wide range of general-purpose applications. The Zero-Drift architecture provides ultra-low offset voltage and near-zero offset voltage drift.

### 7.2 Functional Block Diagram

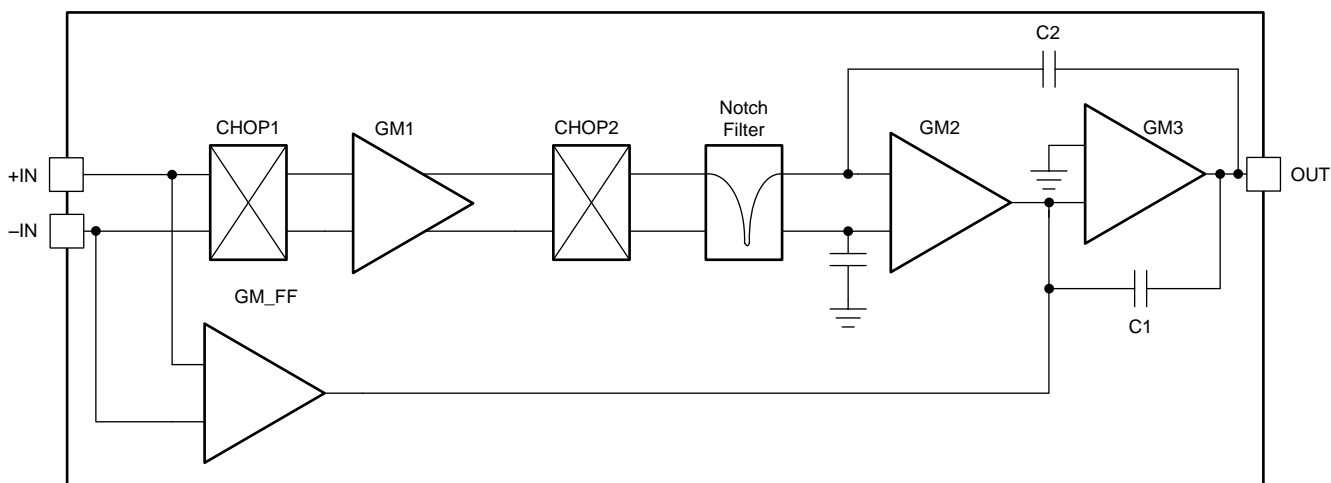

Copyright © 2016, Texas Instruments Incorporated

### 7.3 Feature Description

The OPA2333P is unity-gain stable and free from unexpected output phase reversal. This device uses a proprietary auto-calibration technique to provide low offset voltage and very low drift over time and temperature. For lowest offset voltage and precision performance, optimize circuit layout and mechanical conditions. Avoid temperature gradients that create thermoelectric (Seebeck) effects in the thermocouple junctions formed from connecting dissimilar conductors. Cancel these thermally-generated potentials by assuring they are equal on both input terminals. Other layout and design considerations include:

- Use low thermoelectric-coefficient conditions (avoid dissimilar metals).
- Thermally isolate components from power supplies or other heat sources.
- Shield operational amplifier and input circuitry from air currents, such as cooling fans.

Following these guidelines reduces the likelihood of junctions being at different temperatures, which can cause thermoelectric voltages of 0.1  $\mu\text{V}/^\circ\text{C}$  or higher, depending on materials used.

#### 7.3.1 Operating Voltage

The OPA2333P operational amplifier operates over a power-supply range of 1.8 V to 5.5 V ( $\pm 0.9$  V to  $\pm 2.75$  V). Parameters that vary over supply voltage or temperature are shown in the [Typical Characteristics](#) section.

#### CAUTION

Supply voltages higher than +7 V (absolute maximum) can permanently damage the device.

#### 7.3.2 Input Voltage

The OPA2333P input common-mode voltage range extends 0.1 V beyond the supply rails. The OPA2333P is designed to cover the full range without the troublesome transition region found in some other rail-to-rail amplifiers.

### Feature Description (continued)

Typically, input bias current is approximately 70 pA; however, input voltages that exceed the power supplies can cause excessive current to flow into or out of the input pins. Momentary voltages greater than the power supply can be tolerated if the input current is limited to 10 mA. This limitation is easily accomplished with an input resistor, as shown in [Figure 18](#).

Current-limiting resistor required if input voltage exceeds supply rails by  $\geq 0.5$  V.

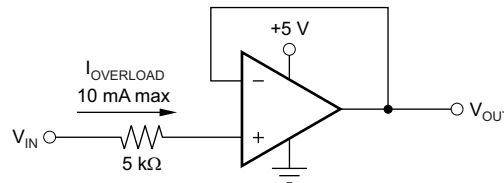

**Figure 18. Input Current Protection**

### 7.3.3 Internal Offset Correction

The OPA2333P operational amplifier uses an auto-calibration technique with a time-continuous 350-kHz operational amplifier in the signal path. This amplifier is zero-corrected every 8  $\mu$ s using a proprietary technique. Upon power up, the amplifier requires approximately 100  $\mu$ s to achieve specified  $V_{OS}$  accuracy. This design has no aliasing or flicker noise.

### 7.3.4 Achieving Output Swing to the Op Amp Negative Rail

Some applications require output voltage swings from 0 V to a positive full-scale voltage (such as 2.5 V) with excellent accuracy. With most single-supply operational amplifiers, problems arise when the output signal approaches 0 V, near the lower output swing limit of a single-supply operational amplifier. A good, single-supply operational amplifier may swing close to single-supply ground, but does not reach ground. The output of the OPA2333P can be made to swing to, or slightly below, ground on a single-supply power source. This swing is achieved with the use of the use of another resistor and an additional, more negative power supply than the operational amplifier negative supply. A pulldown resistor can be connected between the output and the additional negative supply to pull the output down below the value that the output would otherwise achieve, as shown in [Figure 19](#).

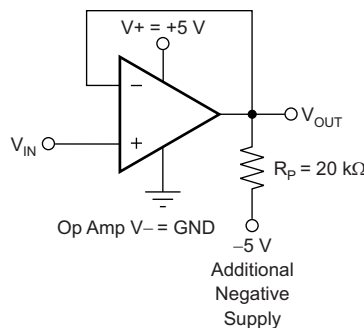

**Figure 19.  $V_{OUT}$  Range to Ground**

## Feature Description (continued)

The OPA2333P has an output stage that allows the output voltage to be pulled to the negative supply rail, or slightly below, using the technique previously described. This technique only works with some types of output stages. The OPA2333P is characterized to perform with this technique; the recommended resistor value is approximately 20 k $\Omega$ .

### NOTE

This configuration increases the current consumption by several hundreds of microamps.

Accuracy is excellent down to 0 V and as low as  $-2$  mV. Limiting and nonlinearity occur below  $-2$  mV, but excellent accuracy returns after the output is again driven above  $-2$  mV. Lowering the resistance of the pulldown resistor allows the operational amplifier to swing even further below the negative rail. Resistances as low as 10 k $\Omega$  can be used to achieve excellent accuracy down to  $-10$  mV.

### 7.3.5 Specified Start-Up Performance

The OPA2333P has a dedicated start-up circuit that ensures a fast, repeatable startup for all supply conditions. The OPA2333P is specified to have a maximum start-up time that is production-tested as illustrated in the configuration shown in Figure 20. Start-up time is defined as the time from when the power supply reaches the minimum specified voltage to the time the output has settled to within 20 mV of the nominal value. See Figure 21.

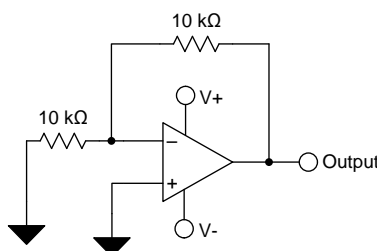

Figure 20. OPA2333P Equivalent Start-Up Test Configuration

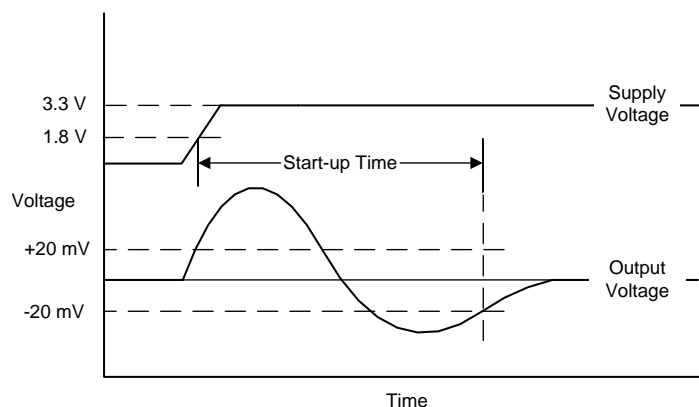

Figure 21. OPA2333P Start-Up Timing

### 7.3.6 DFN Package

The OPA2333P is offered in an DFN-8 package (also known as SOM). The DFN is a QFN package with lead contacts on only two sides of the bottom of the package. This leadless package maximizes board space and enhances thermal and electrical characteristics through an exposed pad.

DFN packages are physically small, have a smaller routing area, improved thermal performance, and improved electrical parasitics. Additionally, the absence of external leads eliminates bent-lead issues.

## Feature Description (continued)

The DFN package can be easily mounted using standard PCB assembly techniques. See application reports [QFN/SON PCB Attachment](#) and [Quad Flatpack No-Lead Logic Packages](#), both available for download at [www.ti.com](http://www.ti.com).

---

### NOTE

The exposed leadframe die pad on the bottom of the package should be connected to V– or left unconnected.

---

## 7.4 Device Functional Modes

The OPA2333P device has a single functional mode. The device is powered on as long as the power supply voltage is between 1.8 V ( $\pm 0.9$  V) and 5.5 V ( $\pm 2.75$  V).

## 8 Application and Implementation

### NOTE

Information in the following applications sections is not part of the TI component specification, and TI does not warrant its accuracy or completeness. TI's customers are responsible for determining suitability of components for their purposes. Customers should validate and test their design implementation to confirm system functionality.

### 8.1 Application Information

The OPA2333P is a unity-gain stable, precision operational amplifier with very low offset voltage drift; these devices are also free from output phase reversal. Applications with noisy or high-impedance power supplies require decoupling capacitors close to the device power-supply pins. In most cases, 0.1- $\mu$ F capacitors are adequate.

### 8.2 Typical Application

#### 8.2.1 Bidirectional Current-Sensing

This single-supply, low-side, bidirectional current-sensing solution detects load currents from  $-1$  A to  $1$  A. The single-ended output spans from  $110$  mV to  $3.19$  V. This design uses the OPA2333P because of its low offset voltage and rail-to-rail input and output. One of the amplifiers is configured as a difference amplifier and the other provides the reference voltage.

Figure 22 shows the solution.

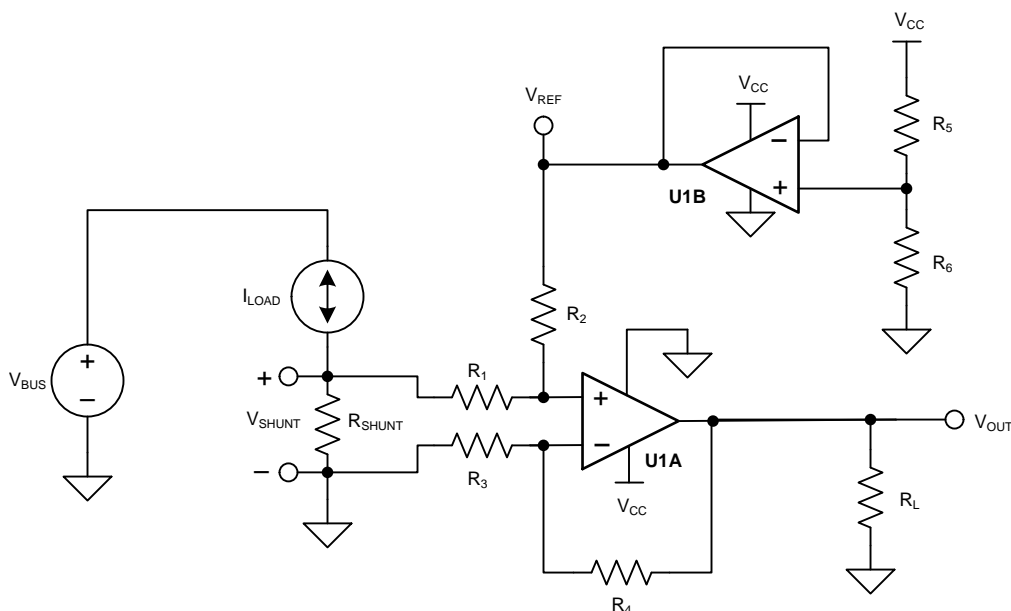

Copyright © 2016, Texas Instruments Incorporated

Figure 22. Bidirectional Current-Sensing Schematic

## Typical Application (continued)

### 8.2.1.1 Design Requirements

This solution has the following requirements:

- Supply voltage: 3.3 V
- Input: –1 A to 1 A
- Output: 1.65 V ±1.54 V (110 mV to 3.19 V)

### 8.2.1.2 Detailed Design Procedure

The load current,  $I_{LOAD}$ , flows through the shunt resistor ( $R_{SHUNT}$ ) to develop the shunt voltage,  $V_{SHUNT}$ . The shunt voltage is then amplified by the difference amplifier, which consists of U1A and  $R_1$  through  $R_4$ . The gain of the difference amplifier is set by the ratio of  $R_4$  to  $R_3$ . To minimize errors, set  $R_2 = R_4$  and  $R_1 = R_3$ . The reference voltage,  $V_{REF}$ , is supplied by buffering a resistor divider using U1B. The transfer function is given by Equation 1.

$$V_{OUT} = V_{SHUNT} \times \text{Gain}_{\text{Diff\_Amp}} + V_{REF}$$

where

- $V_{SHUNT} = I_{LOAD} \times R_{SHUNT}$
  - $\text{Gain}_{\text{Diff\_Amp}} = \frac{R_4}{R_3}$
  - $V_{REF} = V_{CC} \times \left[ \frac{R_6}{R_5 + R_6} \right]$
- (1)

There are two types of errors in this design: offset and gain. Gain errors are introduced by the tolerance of the shunt resistor and the ratios of  $R_4$  to  $R_3$  and, similarly,  $R_2$  to  $R_1$ . Offset errors are introduced by the voltage divider ( $R_5$  and  $R_6$ ) and how closely the ratio of  $R_4/R_3$  matches  $R_2/R_1$ . The latter value impacts the CMRR of the difference amplifier, which ultimately translates to an offset error.

Because this is a low-side measurement, the value of  $V_{SHUNT}$  is the ground potential for the system load. Therefore, it is important to place a maximum value on  $V_{SHUNT}$ . In this design, the maximum value for  $V_{SHUNT}$  is set to 100 mV. Equation 2 calculates the maximum value of the shunt resistor given a maximum shunt voltage of 100 mV and maximum load current of 1 A.

$$R_{SHUNT(\text{Max})} = \frac{V_{SHUNT(\text{Max})}}{I_{LOAD(\text{Max})}} = \frac{100 \text{ mV}}{1 \text{ A}} = 100 \text{ m}\Omega$$
(2)

The tolerance of  $R_{SHUNT}$  is directly proportional to cost. For this design, a shunt resistor with a tolerance of 0.5% was selected. If greater accuracy is required, select a 0.1% resistor or better.

The load current is bidirectional; therefore, the shunt voltage range is –100 mV to 100 mV. This voltage is divided down by  $R_1$  and  $R_2$  before reaching the operational amplifier, U1A. Take care to ensure that the voltage present at the noninverting node of U1A is within the common-mode range of the device. Therefore, it is important to use an operational amplifier, such as the OPA2333P, that has a common-mode range that extends below the negative supply voltage. Finally, to minimize offset error, note that the OPA2333P has a typical offset voltage of ±2  $\mu$ V (±10  $\mu$ V maximum).

Given a symmetric load current of –1 A to 1 A, the voltage divider resistors ( $R_5$  and  $R_6$ ) must be equal. To be consistent with the shunt resistor, a tolerance of 0.5% was selected. To minimize power consumption, 10-k $\Omega$  resistors were used.

To set the gain of the difference amplifier, the common-mode range and output swing of the OPA2333P must be considered. Equation 3 and Equation 4 depict the typical common-mode range and maximum output swing, respectively, of the OPA2333P given a 3.3-V supply.

$$-100 \text{ mV} < V_{CM} < 3.4 \text{ V}$$
(3)

$$100 \text{ mV} < V_{OUT} < 3.2 \text{ V}$$
(4)

The gain of the difference amplifier can now be calculated as shown in Equation 5.

$$\text{Gain}_{\text{Diff\_Amp}} = \frac{V_{OUT\_Max} - V_{OUT\_Min}}{R_{SHUNT} \times (I_{MAX} - I_{MIN})} = \frac{3.2 \text{ V} - 100 \text{ mV}}{100 \text{ m}\Omega \times [1 \text{ A} - (-1 \text{ A})]} = 15.5 \frac{\text{V}}{\text{V}}$$
(5)

### Typical Application (continued)

The resistor value selected for  $R_1$  and  $R_3$  was 1 k $\Omega$ . 15.4 k $\Omega$  was selected for  $R_2$  and  $R_4$  because it is the nearest standard value. Therefore, the ideal gain of the difference amplifier is 15.4 V/V.

The gain error of the circuit primarily depends on  $R_1$  through  $R_4$ . As a result of this dependence, 0.1% resistors were selected. This configuration reduces the likelihood that the design requires a two-point calibration. A simple one-point calibration, if desired, removes the offset errors introduced by the 0.5% resistors.

#### 8.2.1.3 Application Curve

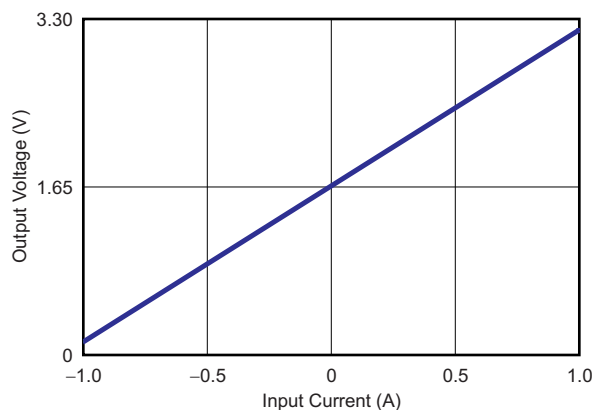

Figure 23. Bidirectional Current-Sensing Circuit Performance: Output Voltage vs Input Current

#### 8.2.2 High-Side Voltage-to-Current (V-I) Converter

The circuit shown in Figure 24 is a high-side voltage-to-current (V-I) converter. It translates an input voltage of 0 V to 2 V to an output current of 0 mA to 100 mA. Figure 25 shows the measured transfer function for this circuit. The low offset voltage and offset drift of the OPA2333P facilitate excellent dc accuracy for the circuit.

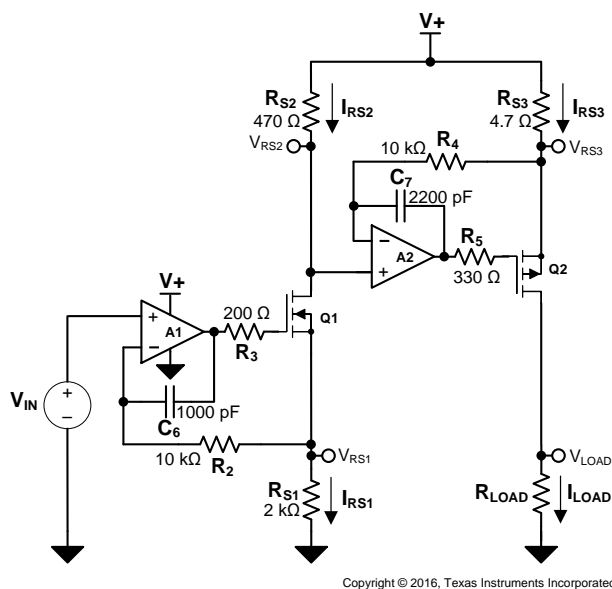

Figure 24. High-Side Voltage-to-Current (V-I) Converter

## Typical Application (continued)

### 8.2.2.1 Design Requirements

The design requirements are as follows:

- Supply Voltage: 5 V DC
- Input: 0 V to 2 V DC
- Output: 0 mA to 100 mA DC

### 8.2.2.2 Detailed Design Procedure

The V-I transfer function of the circuit is based on the relationship between the input voltage,  $V_{IN}$ , and the three current sensing resistors,  $R_{S1}$ ,  $R_{S2}$ , and  $R_{S3}$ . The relationship between  $V_{IN}$  and  $R_{S1}$  determines the current that flows through the first stage of the design. The current gain from the first stage to the second stage is based on the relationship between  $R_{S2}$  and  $R_{S3}$ .

For a successful design, pay close attention to the dc characteristics of the operational amplifier chosen for the application. To meet the performance goals, this application benefits from an operational amplifier with low offset voltage, low temperature drift, and rail-to-rail output. The OPA2333P CMOS operational amplifier is a high-precision, 2- $\mu$ V offset, 0.02- $\mu$ V/ $^{\circ}$ C drift amplifier optimized for low-voltage, single-supply operation with an output swing to within 50 mV of the positive rail. The OPA2333P family uses chopping techniques to provide low initial offset voltage and near-zero drift over time and temperature. Low offset voltage and low drift reduce the offset error in the system, making these devices appropriate for precise dc control. The rail-to-rail output stage of the OPA2333P ensures that the output swing of the operational amplifier is able to fully control the gate of the MOSFET devices within the supply rails.

A detailed error analysis, design procedure, and additional measured results are given in [TIPD102](#).

### 8.2.2.3 Application Curve

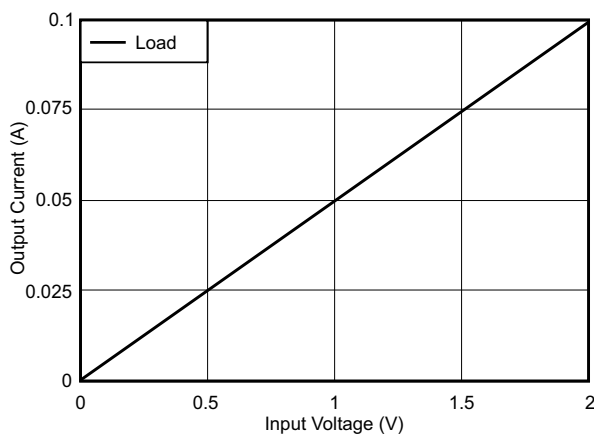
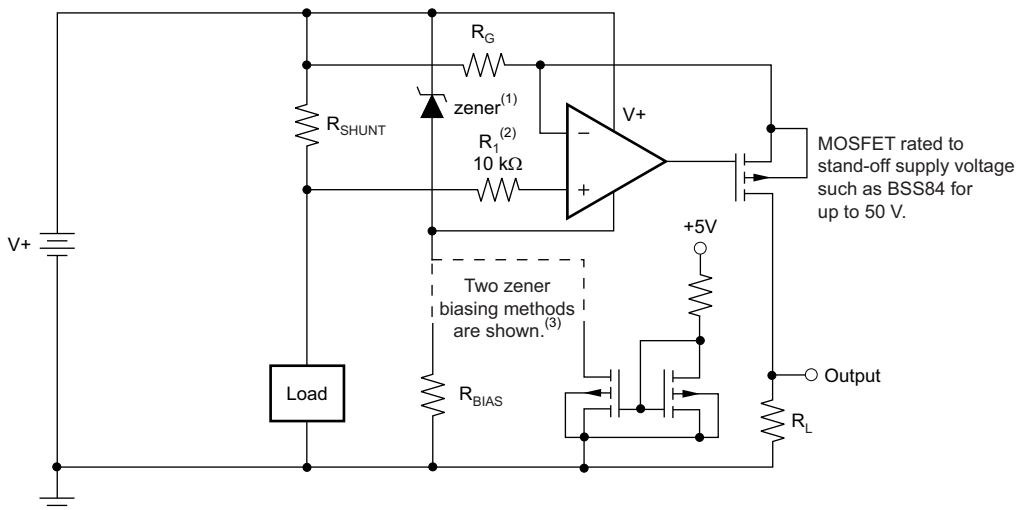

**Figure 25. Measured Transfer Function for High-Side V-I Converter**

Typical Application (continued)

8.2.3 Other Applications

Additional application ideas are shown in Figure 26 through Figure 28.



- (1) Zener rated for op amp supply capability (that is, 5.1 V for OPA2333P).
- (2) Current-limiting resistor.
- (3) Choose zener biasing resistor or dual N-MOSFETs (FDG6301N, NTJD4001N, or Si1034).

Figure 26. High-Side Current Monitor

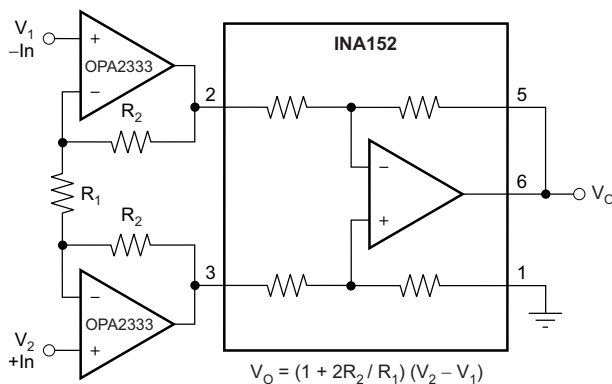
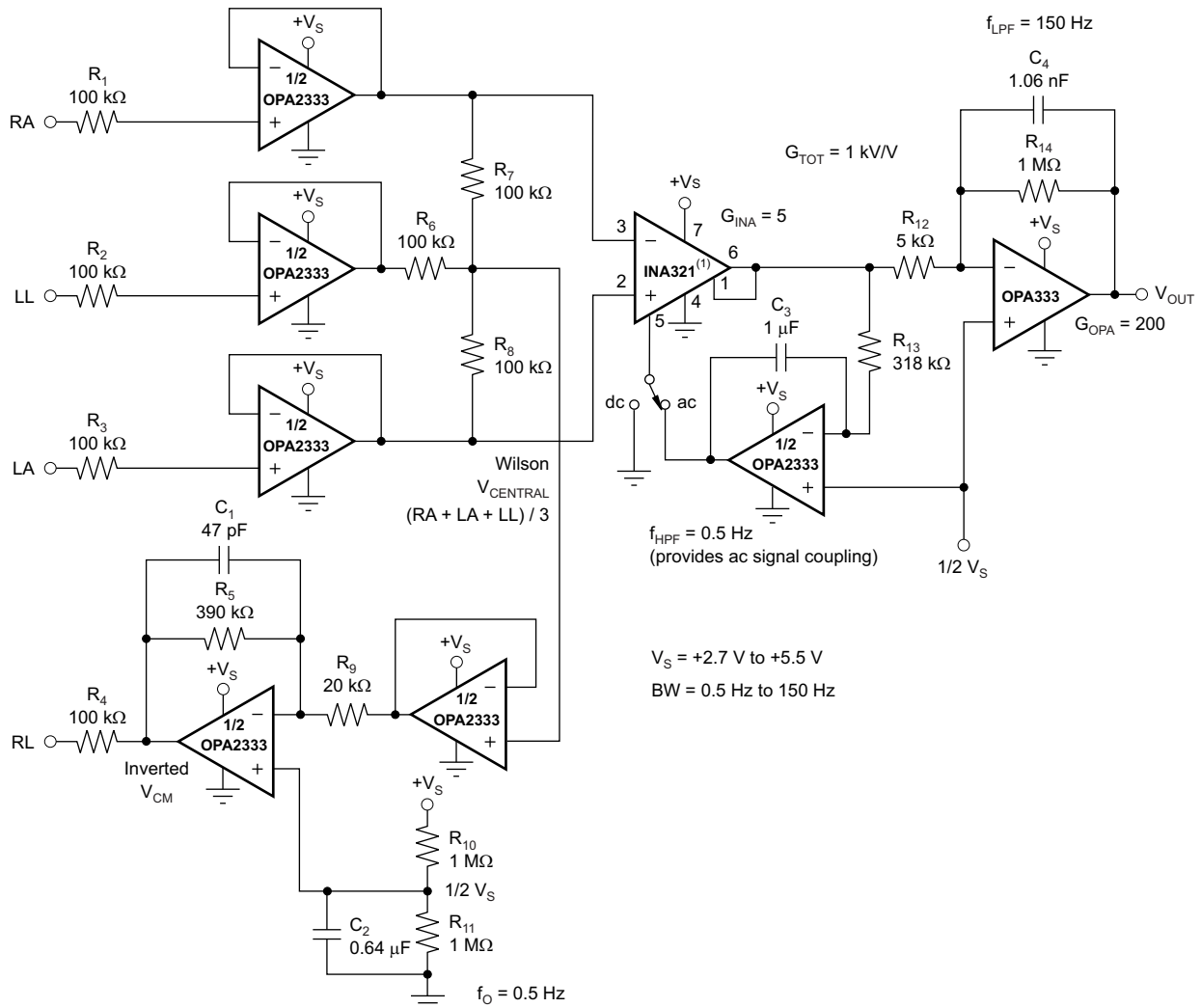

Figure 27. Precision Instrumentation Amplifier

Typical Application (continued)



(1) Other instrumentation amplifiers can be used, such as the [INA326](#), which has lower noise, but higher quiescent current.

Figure 28. Single-Supply, Very Low Power, ECG Circuit

9 Power Supply Recommendations

The OPA2333P is specified for operation from 1.8 V to 5.5 V ( $\pm 0.9$  V to  $\pm 2.75$  V); many specifications apply from  $-40^{\circ}\text{C}$  to  $125^{\circ}\text{C}$ . The [Typical Characteristics](#) presents parameters that can exhibit significant variance with regard to operating voltage or temperature.

**CAUTION**

Supply voltages larger than 7 V can permanently damage the device (see [Absolute Maximum Ratings](#)).

TI recommends placing 0.1- $\mu\text{F}$  bypass capacitors close to the power-supply pins to reduce errors coupling in from noisy or high-impedance power supplies. For more detailed information on bypass capacitor placement, refer to the [Layout](#) section.

## 10 Layout

### 10.1 Layout Guidelines

#### 10.1.1 General Layout Guidelines

Pay attention to good layout practices. Keep traces short and when possible and use a printed-circuit-board (PCB) ground plane with surface-mount components placed as close to the device pins as possible. Place a 0.1- $\mu$ F capacitor closely across the supply pins. Apply these guidelines throughout the analog circuit to improve performance and provide benefits, such as reducing the electromagnetic interference (EMI) susceptibility.

Operational amplifiers vary in susceptibility to radio frequency interference (RFI). RFI can generally be identified as a variation in offset voltage or DC signal levels with changes in the interfering RF signal. The OPA2333P is specifically designed to minimize susceptibility to RFI and demonstrates remarkably low sensitivity compared to previous generation devices. Strong RF fields may still cause varying offset levels.

#### 10.1.2 DFN Layout Guidelines

Solder the exposed leadframe die pad on the DFN package to a thermal pad on the PCB. A mechanical drawing showing an example layout is attached at the end of this data sheet. Refinements to this layout may be necessary based on assembly process requirements. Mechanical drawings located at the end of this data sheet list the physical dimensions for the package and pad. The five holes in the landing pattern are optional, and are intended for use with thermal vias that connect the leadframe die pad to the heatsink area on the PCB.

Soldering the exposed pad significantly improves board-level reliability during temperature cycling, key push, package shear, and similar board-level tests. Even with applications that have low-power dissipation, the exposed pad must be soldered to the PCB to provide structural integrity and long-term reliability.

### 10.2 Layout Example

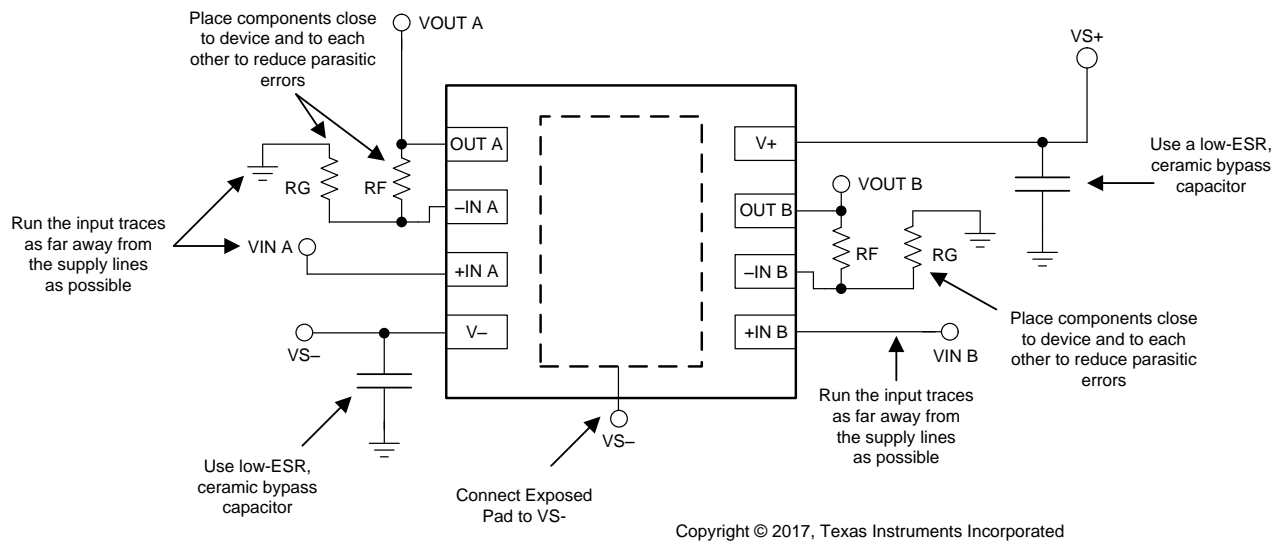

Figure 29. Layout Example

## 11 Device and Documentation Support

### 11.1 Device Support

#### 11.1.1 Development Support

For development support on this product, see the following:

- [High-Side V-I Converter, 0 V to 2 V to 0 mA to 100 mA, 1% Full-Scale Error](#)
- [Low-Level V-to-I Converter Reference Design, 0-V to 5-V Input to 0-μA to 5-μA Output](#)
- [ADS8881x 118-Bit, 1-MSPS, Serial Interface, microPower, Miniature, True-Differential Input, SAR Analog-to-Digital Converter](#)
- [THS4281 Very Low-Power, High-Speed, Rail-to-Rail Input and Output Voltage-Feedback Operational Amplifier](#)
- [Data Acquisition Optimized for Lowest Distortion, Lowest Noise, 18-bit, 1-MSPS Reference Design](#)
- [ADS1100 Self-Calibrating, 16-Bit Analog-to-Digital Converter](#)
- [REF31xx 15ppm/°C Maximum, 100-μA, SOT-23 Series Voltage Reference](#)
- [INA326, INA327 Precision, Low Drift, CMOS Instrumentation Amplifier](#)

### 11.2 Documentation Support

#### 11.2.1 Related Documentation

For related documentation, see the following:

[QFN/SON PCB Attachment](#)

### 11.3 Receiving Notification of Documentation Updates

To receive notification of documentation updates, navigate to the device product folder on ti.com. In the upper right corner, click on *Alert me* to register and receive a weekly digest of any product information that has changed. For change details, review the revision history included in any revised document.

### 11.4 Community Resources

The following links connect to TI community resources. Linked contents are provided "AS IS" by the respective contributors. They do not constitute TI specifications and do not necessarily reflect TI's views; see TI's [Terms of Use](#).

**TI E2E™ Online Community** *TI's Engineer-to-Engineer (E2E) Community*. Created to foster collaboration among engineers. At e2e.ti.com, you can ask questions, share knowledge, explore ideas and help solve problems with fellow engineers.

**Design Support** *TI's Design Support* Quickly find helpful E2E forums along with design support tools and contact information for technical support.

### 11.5 Trademarks

E2E is a trademark of Texas Instruments.  
All other trademarks are the property of their respective owners.

### 11.6 Electrostatic Discharge Caution



These devices have limited built-in ESD protection. The leads should be shorted together or the device placed in conductive foam during storage or handling to prevent electrostatic damage to the MOS gates.

### 11.7 Glossary

[SLYZ022](#) — *TI Glossary*.

This glossary lists and explains terms, acronyms, and definitions.

## 12 Mechanical, Packaging, and Orderable Information

The following pages include mechanical, packaging, and orderable information. This information is the most current data available for the designated devices. This data is subject to change without notice and revision of this document. For browser-based versions of this data sheet, refer to the left-hand navigation.

**PACKAGING INFORMATION**

Orderable Device	Status (1)	Package Type	Package Drawing	Pins	Package Qty	Eco Plan (2)	Lead/Ball Finish (6)	MSL Peak Temp (3)	Op Temp (°C)	Device Marking (4/5)	Samples
OPA2333PIDSGR	PREVIEW	WSON	DSG	8	3000	TBD	Call TI	Call TI	-40 to 125		
OPA2333PIDSGT	PREVIEW	WSON	DSG	8	250	TBD	Call TI	Call TI	-40 to 125		

(1) The marketing status values are defined as follows:

**ACTIVE:** Product device recommended for new designs.

**LIFEBUY:** TI has announced that the device will be discontinued, and a lifetime-buy period is in effect.

**NRND:** Not recommended for new designs. Device is in production to support existing customers, but TI does not recommend using this part in a new design.

**PREVIEW:** Device has been announced but is not in production. Samples may or may not be available.

**OBSOLETE:** TI has discontinued the production of the device.

(2) **RoHS:** TI defines "RoHS" to mean semiconductor products that are compliant with the current EU RoHS requirements for all 10 RoHS substances, including the requirement that RoHS substance do not exceed 0.1% by weight in homogeneous materials. Where designed to be soldered at high temperatures, "RoHS" products are suitable for use in specified lead-free processes. TI may reference these types of products as "Pb-Free".

**RoHS Exempt:** TI defines "RoHS Exempt" to mean products that contain lead but are compliant with EU RoHS pursuant to a specific EU RoHS exemption.

**Green:** TI defines "Green" to mean the content of Chlorine (Cl) and Bromine (Br) based flame retardants meet JS709B low halogen requirements of <=1000ppm threshold. Antimony trioxide based flame retardants must also meet the <=1000ppm threshold requirement.

(3) MSL, Peak Temp. - The Moisture Sensitivity Level rating according to the JEDEC industry standard classifications, and peak solder temperature.

(4) There may be additional marking, which relates to the logo, the lot trace code information, or the environmental category on the device.

(5) Multiple Device Markings will be inside parentheses. Only one Device Marking contained in parentheses and separated by a "~" will appear on a device. If a line is indented then it is a continuation of the previous line and the two combined represent the entire Device Marking for that device.

(6) Lead/Ball Finish - Orderable Devices may have multiple material finish options. Finish options are separated by a vertical ruled line. Lead/Ball Finish values may wrap to two lines if the finish value exceeds the maximum column width.

**Important Information and Disclaimer:** The information provided on this page represents TI's knowledge and belief as of the date that it is provided. TI bases its knowledge and belief on information provided by third parties, and makes no representation or warranty as to the accuracy of such information. Efforts are underway to better integrate information from third parties. TI has taken and continues to take reasonable steps to provide representative and accurate information but may not have conducted destructive testing or chemical analysis on incoming materials and chemicals. TI and TI suppliers consider certain information to be proprietary, and thus CAS numbers and other limited information may not be available for release.

In no event shall TI's liability arising out of such information exceed the total purchase price of the TI part(s) at issue in this document sold by TI to Customer on an annual basis.

## GENERIC PACKAGE VIEW

**DSG 8**

**WSON - 0.8 mm max height**

PLASTIC SMALL OUTLINE - NO LEAD

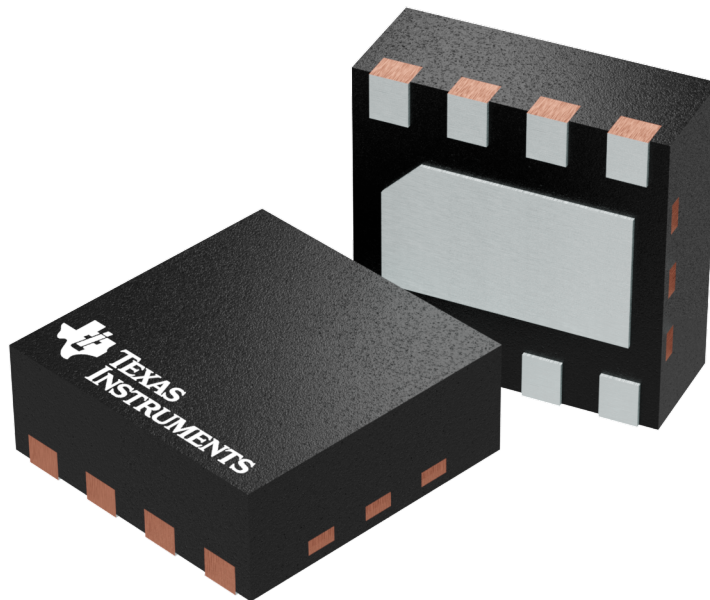

Images above are just a representation of the package family, actual package may vary.  
Refer to the product data sheet for package details.

4208210/C

## IMPORTANT NOTICE

Texas Instruments Incorporated (TI) reserves the right to make corrections, enhancements, improvements and other changes to its semiconductor products and services per JESD46, latest issue, and to discontinue any product or service per JESD48, latest issue. Buyers should obtain the latest relevant information before placing orders and should verify that such information is current and complete.

TI's published terms of sale for semiconductor products (<http://www.ti.com/sc/docs/stdterms.htm>) apply to the sale of packaged integrated circuit products that TI has qualified and released to market. Additional terms may apply to the use or sale of other types of TI products and services.

Reproduction of significant portions of TI information in TI data sheets is permissible only if reproduction is without alteration and is accompanied by all associated warranties, conditions, limitations, and notices. TI is not responsible or liable for such reproduced documentation. Information of third parties may be subject to additional restrictions. Resale of TI products or services with statements different from or beyond the parameters stated by TI for that product or service voids all express and any implied warranties for the associated TI product or service and is an unfair and deceptive business practice. TI is not responsible or liable for any such statements.

Buyers and others who are developing systems that incorporate TI products (collectively, "Designers") understand and agree that Designers remain responsible for using their independent analysis, evaluation and judgment in designing their applications and that Designers have full and exclusive responsibility to assure the safety of Designers' applications and compliance of their applications (and of all TI products used in or for Designers' applications) with all applicable regulations, laws and other applicable requirements. Designer represents that, with respect to their applications, Designer has all the necessary expertise to create and implement safeguards that (1) anticipate dangerous consequences of failures, (2) monitor failures and their consequences, and (3) lessen the likelihood of failures that might cause harm and take appropriate actions. Designer agrees that prior to using or distributing any applications that include TI products, Designer will thoroughly test such applications and the functionality of such TI products as used in such applications.

TI's provision of technical, application or other design advice, quality characterization, reliability data or other services or information, including, but not limited to, reference designs and materials relating to evaluation modules, (collectively, "TI Resources") are intended to assist designers who are developing applications that incorporate TI products; by downloading, accessing or using TI Resources in any way, Designer (individually or, if Designer is acting on behalf of a company, Designer's company) agrees to use any particular TI Resource solely for this purpose and subject to the terms of this Notice.

TI's provision of TI Resources does not expand or otherwise alter TI's applicable published warranties or warranty disclaimers for TI products, and no additional obligations or liabilities arise from TI providing such TI Resources. TI reserves the right to make corrections, enhancements, improvements and other changes to its TI Resources. TI has not conducted any testing other than that specifically described in the published documentation for a particular TI Resource.

Designer is authorized to use, copy and modify any individual TI Resource only in connection with the development of applications that include the TI product(s) identified in such TI Resource. NO OTHER LICENSE, EXPRESS OR IMPLIED, BY ESTOPPEL OR OTHERWISE TO ANY OTHER TI INTELLECTUAL PROPERTY RIGHT, AND NO LICENSE TO ANY TECHNOLOGY OR INTELLECTUAL PROPERTY RIGHT OF TI OR ANY THIRD PARTY IS GRANTED HEREIN, including but not limited to any patent right, copyright, mask work right, or other intellectual property right relating to any combination, machine, or process in which TI products or services are used. Information regarding or referencing third-party products or services does not constitute a license to use such products or services, or a warranty or endorsement thereof. Use of TI Resources may require a license from a third party under the patents or other intellectual property of the third party, or a license from TI under the patents or other intellectual property of TI.

TI RESOURCES ARE PROVIDED "AS IS" AND WITH ALL FAULTS. TI DISCLAIMS ALL OTHER WARRANTIES OR REPRESENTATIONS, EXPRESS OR IMPLIED, REGARDING RESOURCES OR USE THEREOF, INCLUDING BUT NOT LIMITED TO ACCURACY OR COMPLETENESS, TITLE, ANY EPIDEMIC FAILURE WARRANTY AND ANY IMPLIED WARRANTIES OF MERCHANTABILITY, FITNESS FOR A PARTICULAR PURPOSE, AND NON-INFRINGEMENT OF ANY THIRD PARTY INTELLECTUAL PROPERTY RIGHTS. TI SHALL NOT BE LIABLE FOR AND SHALL NOT DEFEND OR INDEMNIFY DESIGNER AGAINST ANY CLAIM, INCLUDING BUT NOT LIMITED TO ANY INFRINGEMENT CLAIM THAT RELATES TO OR IS BASED ON ANY COMBINATION OF PRODUCTS EVEN IF DESCRIBED IN TI RESOURCES OR OTHERWISE. IN NO EVENT SHALL TI BE LIABLE FOR ANY ACTUAL, DIRECT, SPECIAL, COLLATERAL, INDIRECT, PUNITIVE, INCIDENTAL, CONSEQUENTIAL OR EXEMPLARY DAMAGES IN CONNECTION WITH OR ARISING OUT OF TI RESOURCES OR USE THEREOF, AND REGARDLESS OF WHETHER TI HAS BEEN ADVISED OF THE POSSIBILITY OF SUCH DAMAGES.

Unless TI has explicitly designated an individual product as meeting the requirements of a particular industry standard (e.g., ISO/TS 16949 and ISO 26262), TI is not responsible for any failure to meet such industry standard requirements.

Where TI specifically promotes products as facilitating functional safety or as compliant with industry functional safety standards, such products are intended to help enable customers to design and create their own applications that meet applicable functional safety standards and requirements. Using products in an application does not by itself establish any safety features in the application. Designers must ensure compliance with safety-related requirements and standards applicable to their applications. Designer may not use any TI products in life-critical medical equipment unless authorized officers of the parties have executed a special contract specifically governing such use. Life-critical medical equipment is medical equipment where failure of such equipment would cause serious bodily injury or death (e.g., life support, pacemakers, defibrillators, heart pumps, neurostimulators, and implantables). Such equipment includes, without limitation, all medical devices identified by the U.S. Food and Drug Administration as Class III devices and equivalent classifications outside the U.S.

TI may expressly designate certain products as completing a particular qualification (e.g., Q100, Military Grade, or Enhanced Product). Designers agree that it has the necessary expertise to select the product with the appropriate qualification designation for their applications and that proper product selection is at Designers' own risk. Designers are solely responsible for compliance with all legal and regulatory requirements in connection with such selection.

Designer will fully indemnify TI and its representatives against any damages, costs, losses, and/or liabilities arising out of Designer's non-compliance with the terms and provisions of this Notice.