

SERIES 22 SQUARE FLANGE RECEPTACLE IN STANDARD OR SCOOP-PROOF SHELL WITH PIN OR SOCKET CONTACTS



How To Order					
Sample Part Number	220-02	E	24-61	P	N
Series and Shell Style	220-02 - Standard 220-12 - Scoop-Proof				
Class	H = Hermetic E = Environmental				
Shell Size - Insert Arrangement	See page A-6				
Contact Style	P = Pin S = Socket C = Pin, PC Termination D = Socket, PC Termination				
Polarization	N, 1, 2, 3, 4 See page A-6				

Prior to use, lubricate o-rings with high grade silicone lubricant (Moly-kote M55 or equivalent).

B

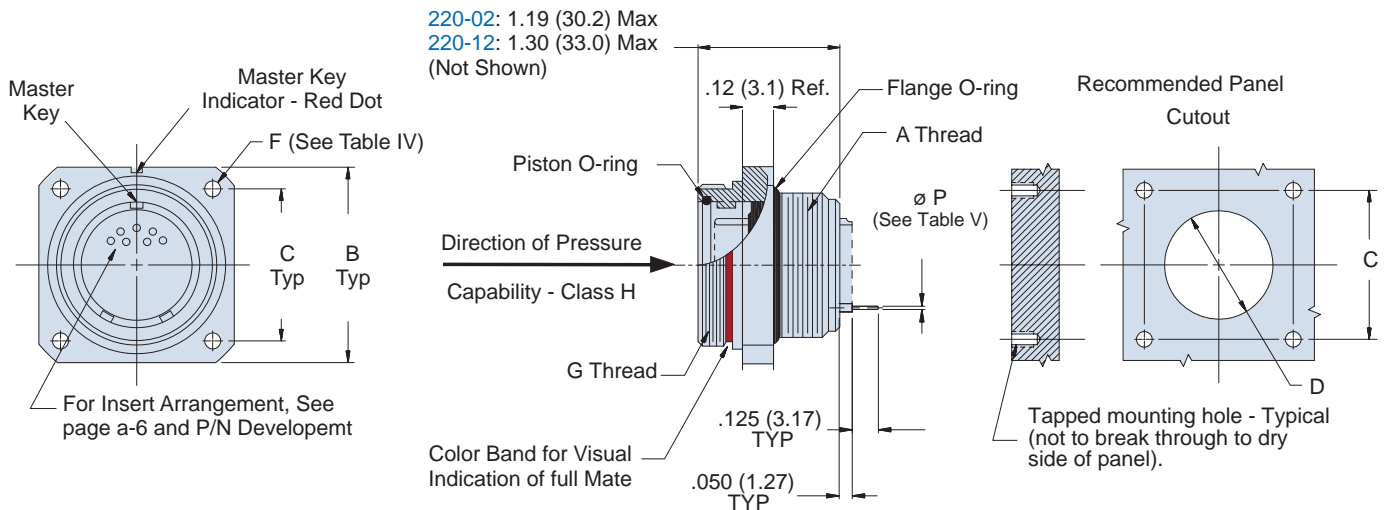

220-02 and 220-12 High-Pressure Environmental/Hermetic Square Flange Mount Receptacle

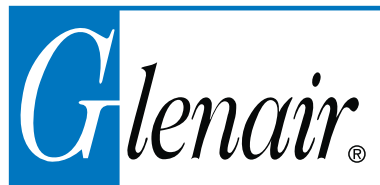

Table II: Dimensions

Shell Size	A Thread Class 2A	B Dim	C Dim	D Dia +.015 +(0.4) -.000 -(0.0)	G Thread Class 2A
10	5/8 - 24 UNEF	1.188 (30.2)	.938 (23.8)	.844 (21.4)	.750 - .1P - .1L
12	3/4 - 20 UNEF	1.312 (33.3)	1.062 (27.0)	.969 (24.6)	.875 - .1P - .1L
14	7/8 - 20 UNEF	1.438 (36.5)	1.188 (30.2)	1.078 (27.4)	1.000 - .1P - .1L
16	1 - 20 UNEF	1.562 (39.7)	1.250 (31.8)	1.219 (31.0)	1.125 - .1P - .1L
18	1 1/8 - 16 UN	1.750 (44.5)	1.375 (34.9)	1.359 (34.5)	1.250 - .1P - .1L
20	1 1/4 - 16 UN	1.875 (47.6)	1.500 (38.1)	1.515 (38.5)	1.375 - .1P - .1L
22	1 3/8 - 16 UN	2.000 (50.8)	1.625 (41.3)	1.640 (41.7)	1.500 - .1P - .1L
24	1 1/2 - 6 UN	2.125 (54.0)	1.750 (44.5)	1.765 (44.8)	1.625 - .1P - .1L

Table IV: Mounting/Hardware Information

Shell Size	F Dia	Mtg Screw Ref.
10	.125 (3.2)	No. 4
12	.125 (3.2)	No. 4
14	.125 (3.2)	No. 4
16	.125 (3.2)	No. 4
18	.125 (3.2)	No. 4
20	.125 (3.2)	No. 4
22	.125 (3.2)	No. 4
24	.156 (4.0)	No. 6

Table VI: Replacement O-Ring Part Numbers

Shell Size	Piston O-Ring	Flange O-Ring
10	2-014	2-021
12	2-016	2-023
14	2-018	2-025
16	2-020	2-027
18	2-022	2-029
20	2-024	2-030
22	2-026	2-031
24	2-028	2-032

*Parker o-ring part numbers
Compound N674-70 or equivalent.

Table V

Contact Size	Ø P
22D	0.021
	0.018
20	0.024
	0.028
16	0.0635
	0.0615
12	0.095
	0.093

