

Super-mini Terminal Block Signal Conditioners M5-UNIT

THERMOCOUPLE TRANSMITTER

Functions & Features

- Accepts direct input from a thermocouple and provides a standard process signal
- Linearization and burnout
- Cold junction compensation
- Fast response type available
- High-density mounting
- Power LED

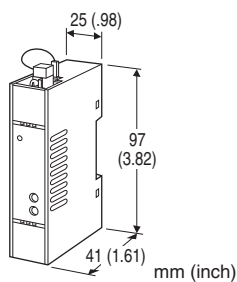

MODEL: M5TS-[1][2]-[3][4]

ORDERING INFORMATION

- Code number: M5TS-[1][2]-[3][4]
- Specify a code from below for each [1] through [4].
(e.g. M5TS-2A-R/K/BL/Q)
- Temperature range (e.g. 0 - 800°C)
 - Special output range (For codes Z, 0 & 01)
 - Specify the specification for option code /Q
(e.g. /C01/V01/S01)

[1] INPUT THERMOCOUPLE

- 1: (PR) (Usable Range 0 to 1760°C, 32 to 3200°F)
- 2: K (CA) (Usable range -270 to +1370°C, -454 to +2498°F)
- 3: E (CRC) (Usable range -270 to +1000°C, -454 to +1832°F)
- 4: J (IC) (Usable range -210 to +1200°C, -346 to +2192°F)
- 5: T (CC) (Usable range -270 to +400°C, -454 to +752°F)
- 6: B (RH) (Usable range 0 to 1820°C, 32 to 3308°F)
- 7: R (Usable range -50 to +1760°C, -58 to +3200°F)
- 8: S (Usable range -50 to +1760°C, -58 to +3200°F)
- N: N (Usable range -270 to +1300°C, -454 to +2372°F)
- 0: Specify

[2] OUTPUT

Current

- A: 4 - 20 mA DC (Load resistance 550 Ω max.)
- D: 0 - 20 mA DC (Load resistance 550 Ω max.)
- Z: Specify current (See OUTPUT SPECIFICATIONS)

Voltage

- 1: 0 - 10 mV DC (Load resistance 100 kΩ min.)
(CE not available)
- 2: 0 - 100 mV DC (Load resistance 100 kΩ min.)
(CE not available)
- 3: 0 - 1 V DC (Load resistance 100 Ω min.)
- 4: 0 - 10 V DC (Load resistance 1000 Ω min.)
- 5: 0 - 5 V DC (Load resistance 500 Ω min.)
- 6: 1 - 5 V DC (Load resistance 500 Ω min.)
- 1W: -10 - +10 mV DC (Load resistance 100 kΩ min.)
(CE not available)
- 2W: -100 - +100 mV DC (Load resistance 100 kΩ min.)
(CE not available)
- 3W: -1 - +1 V DC (Load resistance 800 Ω min.)
- 4W: -10 - +10 V DC (Load resistance 8000 Ω min.)
- 5W: -5 - +5 V DC (Load resistance 4000 Ω min.)
- 0: Specify voltage (See OUTPUT SPECIFICATIONS)
- 01: Specify voltage (See OUTPUT SPECIFICATIONS)
(CE not available)

[3] POWER INPUT

AC Power

- M: 85 - 264 V AC (Operational voltage range 85 - 264 V, 47 - 66 Hz)
(CE not available)

DC Power

- R: 24 V DC
(Operational voltage range 24 V ±10 %, ripple 10 %p-p max.)

[4] OPTIONS (multiple selections)

Response Time (0 - 90 %)

- blank: Standard (≤ 0.5 sec.)
- /K: Fast Response (Approx. 25 msec.)

Burnout

- blank: Upscale burnout
- /BL: Downscale burnout
- /BN: No burnout

Other Options

- blank: none
- /Q: Option other than the above (specify the specification)

SPECIFICATIONS OF OPTION: Q (multiple selections)

COATING (For the detail, refer to M-System's web site.)

- /C01: Silicone coating
- /C02: Polyurethane coating
- /C03: Rubber coating

ADJUSTMENT

- /V01: Multi-turn fine adjustment

TERMINAL SCREW MATERIAL

- /S01: Stainless steel

GENERAL SPECIFICATIONS

Construction: Terminal block
Connection: M3.5 screw terminals (torque 0.8 N·m)
Screw terminal: Nickel-plated steel (standard) or stainless steel
Housing material: Flame-resistant resin (black)
Isolation: Input to output to power
Overrange output: Approx. -10 to +110 % at 1 - 5 V
Zero adjustment: -2 to +2 % (front)
Span adjustment: 98 to 102 % (front)
At burnout: Downscale \leq -10 %, Upscale \geq 110 %,
 For output code 4W, Downscale \leq -3%, Upscale \geq 103%
Linearization: Standard
Cold junction compensation: CJC sensor attached to the input terminals
Power LED: Green LED turns on when the power is supplied.

INPUT SPECIFICATIONS

Minimum span: 3 mV
Input resistance: 20 k Ω min.
Burnout sensing: 0.1 μ A

Lower temperature range & span (in °C)

(PR): Lower range 0 to 880°C; min. span 370°C
K (CA): Lower range -270 to +1200°C; min. span 75°C
E (CRC): Lower range -270 to +750°C; min. span 50°C
J (IC): Lower range -210 to +800°C; min. span 60°C
T (CC): Lower range -270 to +325°C; min. span 75°C
B (RH): Lower range 0 to 750°C; min. span 780°C
R: Lower range -50 to +550°C; min. span 360°C
S: Lower range -50 to +550°C; min. span 380°C
N: Lower range -270 to +1100°C; min. span 110°C

Lower temperature range & span (in °F)

(PR): Lower range 32 to 1616°F; min. span 670°F
K (CA): Lower range -454 to +2192°F; min. span 140°F
E (CRC): Lower range -454 to +1382°F; min. span 90°F
J (IC): Lower range -346 to +1472°F; min. span 110°F
T (CC): Lower range -454 to +617°F; min. span 140°F
B (RH): Lower range 32 to 1382°F; min. span 1450°F
R: Lower range -58 to +1022°F; min. span 680°F
S: Lower range -58 to +1022°F; min. span 700°F
N: Lower range -454 to +2012°F; min. span 200°F

Note 1: The described accuracy may be partially not satisfied when the temperature ranges below 0°C. Consult M-System.

Note 2: Consult M-System for the range out of the above list.

OUTPUT SPECIFICATIONS

■ **DC Current:** 0 - 20 mA DC
Minimum span: 1 mA
Offset: Max. 1.5 times span
Load resistance: Output drive 11 V max.
 ■ **DC Voltage**
 • **Output code 0 (CE)**
Voltage range: -10 - +10 V DC
Minimum span: 1 V
Offset: Max. 1.5 times span
Load resistance: Output drive 10 mA max.; at \geq 1 V
 Max. 1.25 mA output drive for negative voltage
 • **Output code 01 (Not CE)**
Voltage range: -1 - +1 V DC
Minimum span: 10 mV
Offset: Max. 1.5 times span
Load resistance: Min. 100 k Ω
 Min. 1 M Ω for negative voltage

INSTALLATION

Power Consumption

• **AC:**
 Approx. 2 VA at 100 V
 Approx. 3 VA at 200 V
 Approx. 3 VA at 264 V
 • **DC:** Approx. 2 W
Operating temperature: -5 to +55°C (23 to 131°F)
Operating humidity: 0 to 90 %RH (non-condensing)
Mounting: DIN rail
Weight: 80 g (2.8 oz)

PERFORMANCE in percentage of span

Accuracy (whichever is greater)
K, E, J: \pm 0.1 % of FS or \pm 0.2°C (\pm 0.36°F)
T, N: \pm 0.2 % of FS or \pm 0.2°C (\pm 0.36°F)
PR, B, R, S: \pm 0.3 % of FS
 (at over 400°C for R, S and PR; over 770°C for B)
Cold junction compensation error
 (at 20°C \pm 10°C or 68°F \pm 18°F)
K, E, J, T, N: \pm 0.5°C or \pm 0.9°F
S, R, PR: \pm 1°C or \pm 1.8°F
Temp. coefficient: \pm 0.015 %/°C (\pm 0.008 %/°F)
 (at over 400°C or 750°F for R, S and PR; over 770°C or 1420°F for B)
Burnout response: \leq 10 sec.
Line voltage effect: \pm 0.1 % over voltage range
Insulation resistance: \geq 100 M Ω with 500 V DC
Dielectric strength (input to output to power to ground)
DC powered: 2000 V AC @1 minute
AC powered: 1500 V AC @1 minute

STANDARDS & APPROVALS

EU conformity:
EMC Directive
EMI EN 61000-6-4
EMS EN 61000-6-2
RoHS Directive
EN 50581

FRONT VIEW

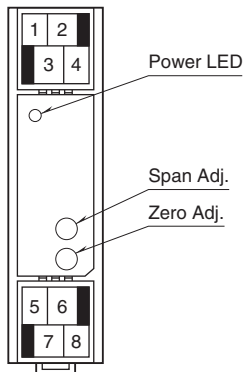

EXTERNAL DIMENSIONS unit: mm (inch)

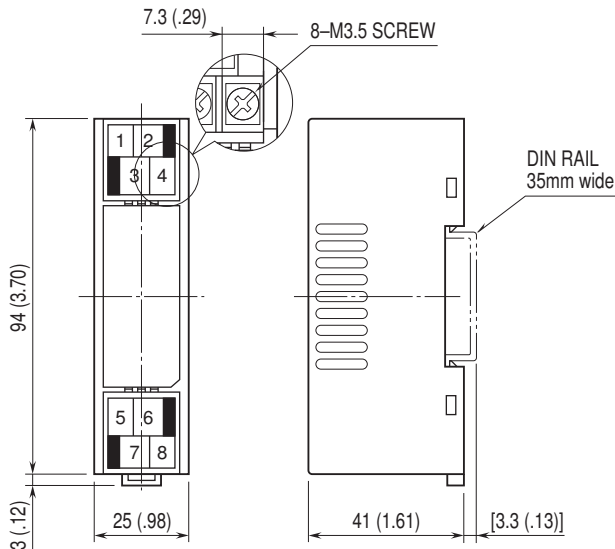

• When mounting, no extra space is needed between units.

TERMINAL ASSIGNMENTS unit: mm (inch)

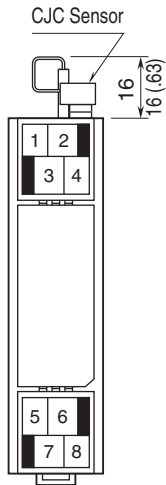

SCHEMATIC CIRCUITRY & CONNECTION DIAGRAM

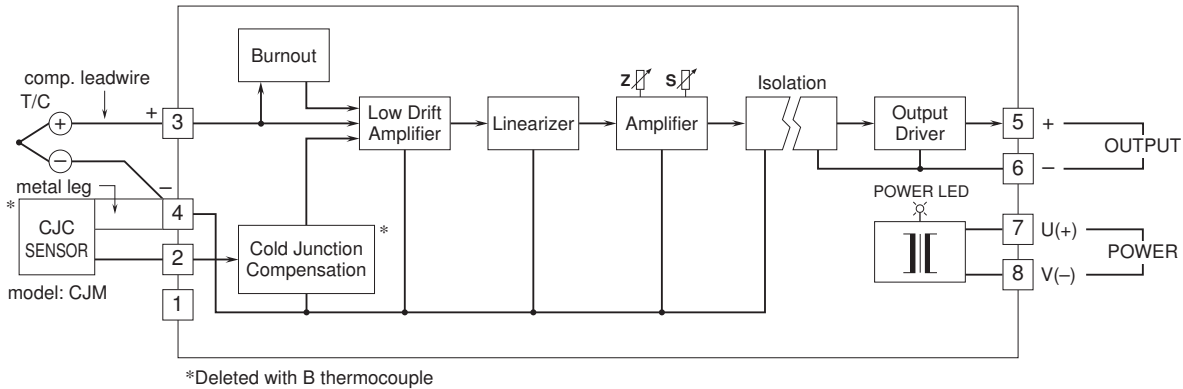

Specifications are subject to change without notice.