

SOLIDWORK GENERATED DRAWING, DON'T CHANGE BY HAND

REV.	ECN. NO.	APPD.
A	BC-13-0030642	C.S. Li
B	BC-13-0061596	C.S. Li

NOTES:

- ELECTRICAL CHARACTERISTICS:
 - CONTACT CURRENT RATING: 0.5 AMPERE MAX. PER PIN.
 - VOLTAGE RATING: 50V AC.
 - INSULATION RESISTANCE :500 MEGAOHMS MIN. AT 500V DC.
 - DIELECTRIC WITHSTANDING VOLTAGE: 300V AC RMS AT 60Hz, FOR 1 MINUTE.
 - CONTACT RESISTANCE: 55 MILLIOHMS MAX. PER PIN INITIAL.
 $\Delta R=20$ MILLIOHMS MAX. PER PIN AFTER FULL ENVIRONMENT TESTING.
- MECHANICAL CHARACTERISTICS: DURABILITY: 60 MATING CYCLES.
- OPERATION TEMPERATURE: -40°C TO +80°C.
- RECOMMENDED PROCESS CONDITION: SMT, PEAK TEMPERATURE: 260°C, 10~20S.
- KEY LABEL "*" IS A CAPITAL LETTER PER THE PART NO.
- PLEASE CONTACT FOXCONN SALES REPRESENTATIVE TO VERIFY PRODUCT DETAIL & AVAILABILITY.

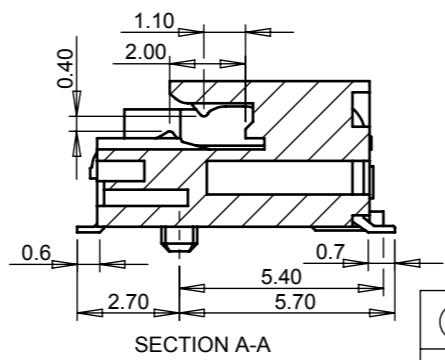
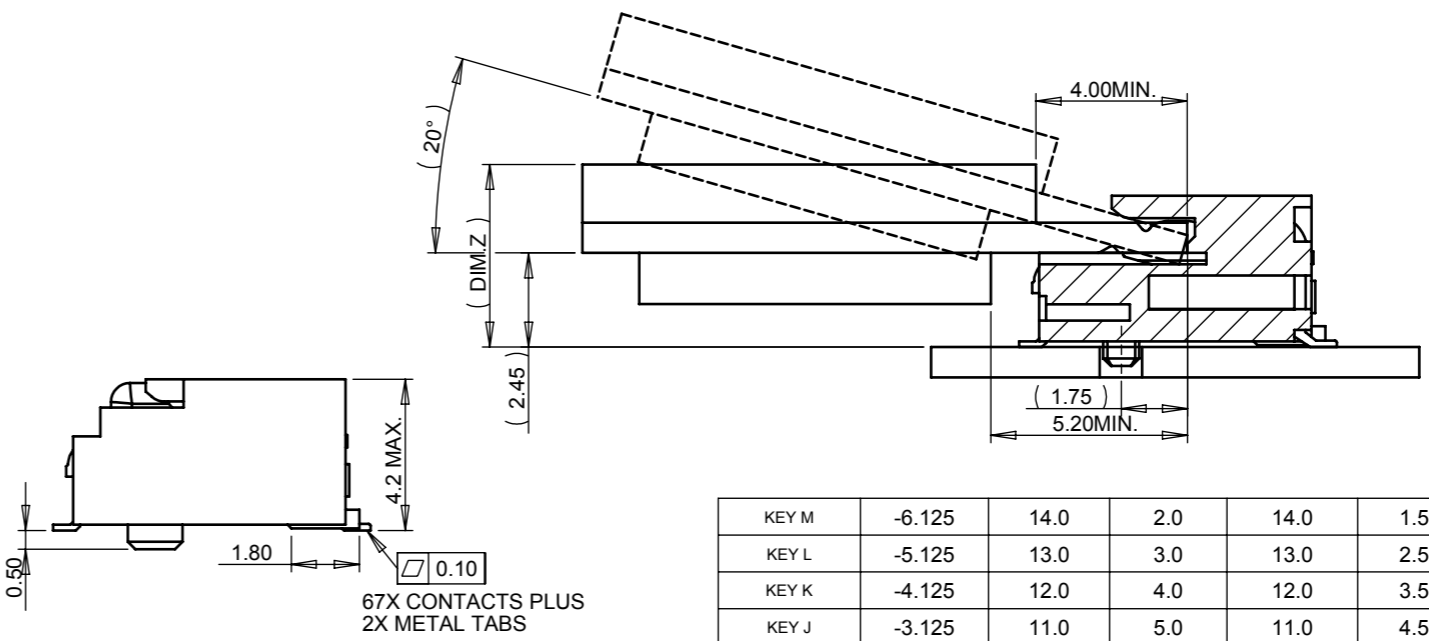
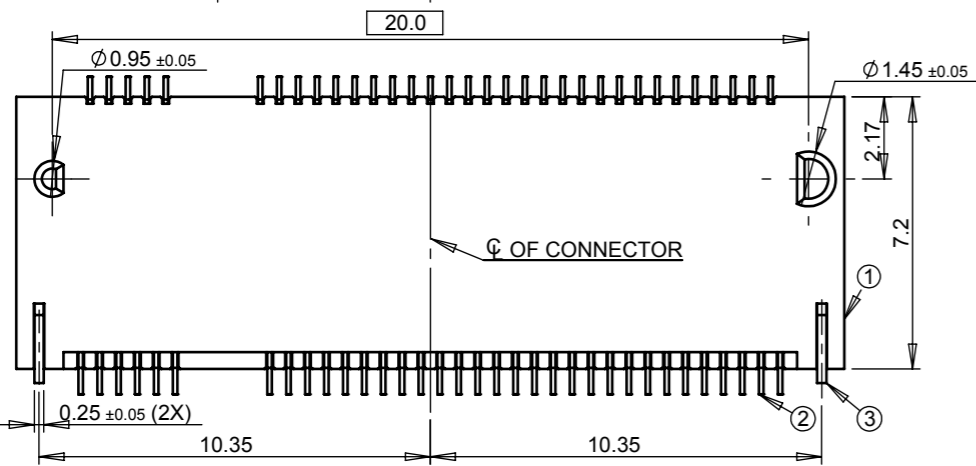
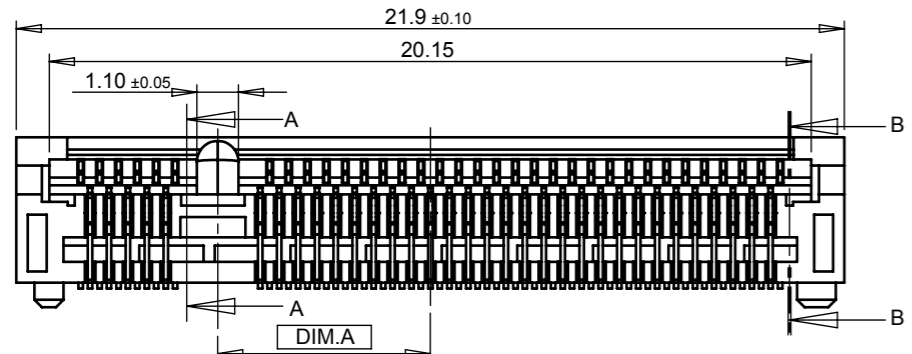
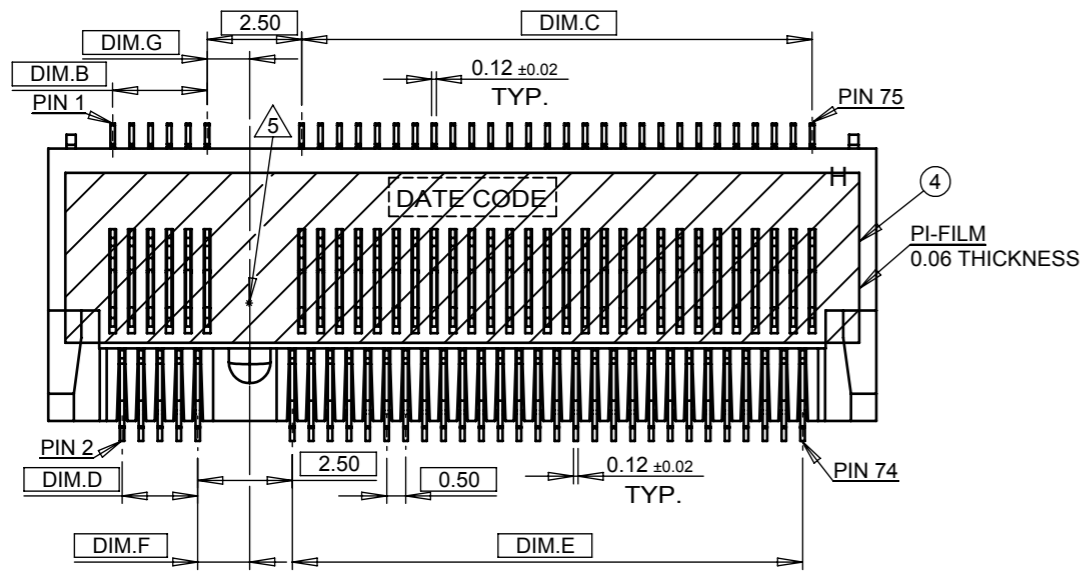

DIM.Z MAX.(mm)	MODULE TYPE
4.65	S1&D1
4.70	S2&D2
4.85	S3&D3&D4&D5

KEY NAME	DIM.A	DIM.B	DIM.C	DIM.D	DIM.E	DIM.F	DIM.G	P/N
KEY M	-6.125	14.0	2.0	14.0	1.5	1.125	1.375	AS0BC2*-S40BM-7H
KEY L	-5.125	13.0	3.0	13.0	2.5	1.125	1.375	AS0BC2*-S40BL-7H
KEY K	-4.125	12.0	4.0	12.0	3.5	1.125	1.375	AS0BC2*-S40BK-7H
KEY J	-3.125	11.0	5.0	11.0	4.5	1.125	1.375	AS0BC2*-S40BJ-7H
KEY H	-2.125	10.0	6.0	10.0	5.5	1.125	1.375	AS0BC2*-S40BH-7H
KEY G	-1.125	9.0	7.0	9.0	6.5	1.125	1.375	AS0BC2*-S40BG-7H
KEY F	1.625	6.5	9.5	6.0	9.5	1.375	1.125	AS0BC2*-S40BF-7H
KEY E	2.625	5.5	10.5	5.0	10.5	1.375	1.125	AS0BC2*-S40BE-7H
KEY D	3.625	4.5	11.5	4.0	11.5	1.375	1.125	AS0BC2*-S40BD-7H
KEY C	4.625	3.5	12.5	3.0	12.5	1.375	1.125	AS0BC2*-S40BC-7H
KEY B	5.625	2.5	13.5	2.0	13.5	1.375	1.125	AS0BC2*-S40BB-7H
KEY A	6.625	1.5	14.5	1.0	14.5	1.375	1.125	AS0BC2*-S40BA-7H

ITEM	DESCRIPTION	MATERIAL	Q'TY	TREATMENT
④	PI-FILM	POLYIMIDE	1	BROWN COLOR
③	METAL TAB	STAINLESS STEEL	2	10u" NICKEL UNDER PLATING 100u" MATTE TIN PLATING OVER ALL
②	CONTACT	COPPER ALLOY	67	50u" NICKEL UNDER PLATING GOLD FLASH PLATING AT TAIL AREA 5u" GOLD PLATING OR 10u" GOLD PLATING OR 15u" GOLD PLATING OR 30u" GOLD PLATING OR GOLD FLASH AT CONTACT AREA
①	HOUSING	THERMOPLASTIC	1	UL94V-0, HALOGEN FREE, BLACK COLOR

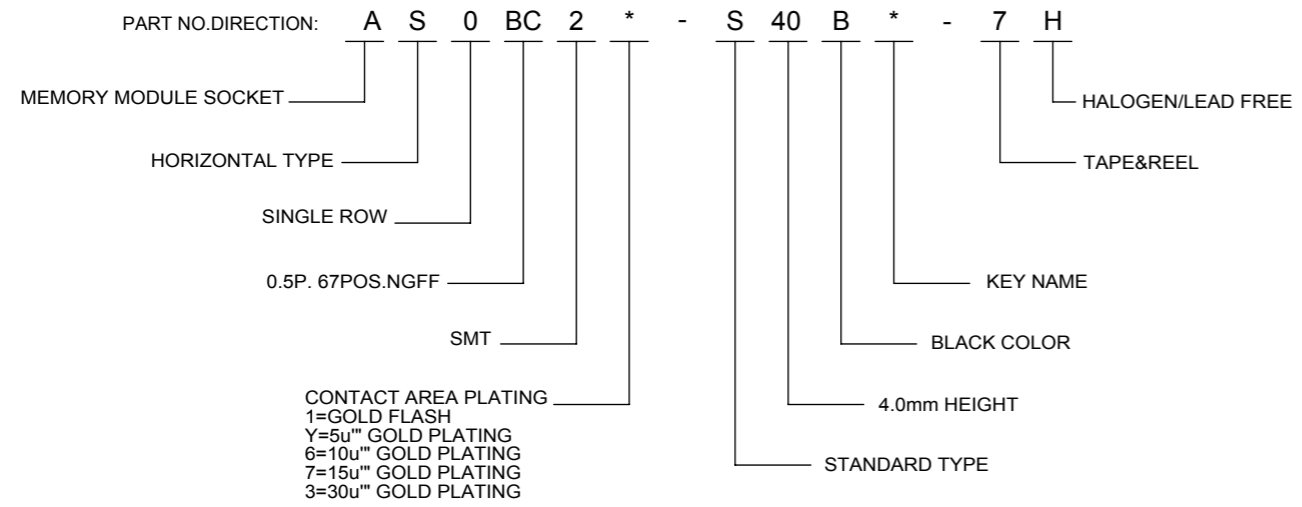

UNITS	mm	NAME (INTENDED USE)	FOXCONN
X ± 0.30	X ±	NGFF CONNECTOR	HON HAI PRECISION IND. CO., LTD. TAIPEI, TAIWAN, R.O.C.
.X ± 0.25	.X ±	PART NO. (INTENDED USE)	TITLE:
.XX ± 0.15	.XX ±	AS0BC2*-S40B*-7H	CUSTOMER DRAWING
.XXX ±	.XXX ±	APPD: C.S. Li	DWG NO.: 317-0000-2175
THESE DRAWINGS AND SPECIFICATIONS ARE THE PROPERTY OF HON HAI PRECISION IND. CO., LTD. AND SHALL NOT BE REPRODUCED, COPIED OR USED IN ANY MANNER WITHOUT THE PRIOR WRITTEN CONSENT OF HON HAI PRECISION IND. CO., LTD.		CHKD: Alex Wang	SCALE SHEET REV.
		DR: FL Liu 8/23'13	N/A 1/4 B

SOLIDWORK GENERATED DRAWING, DON'T CHANGE BY HAND

REV.	ECN. NO	APPD

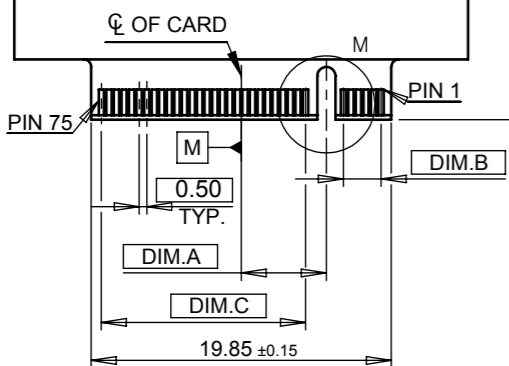
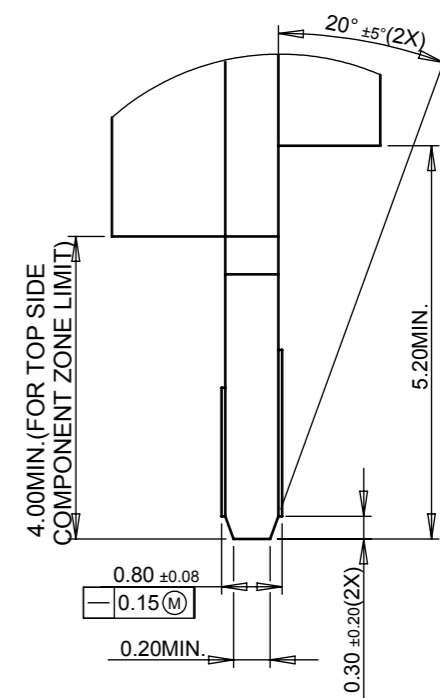
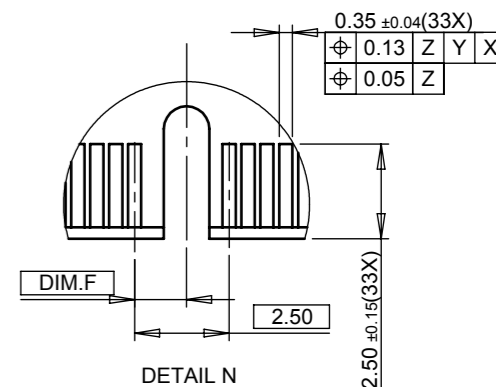
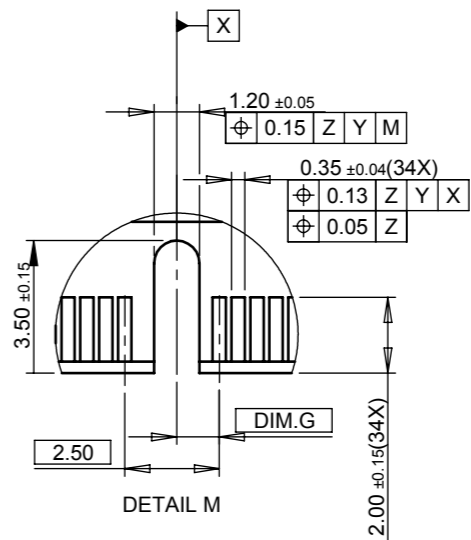
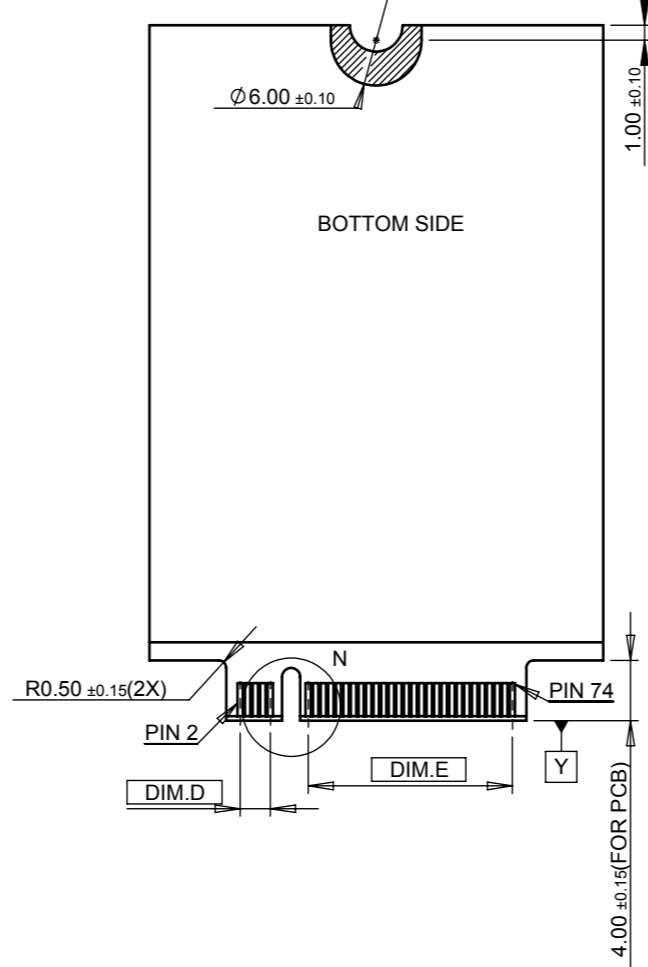
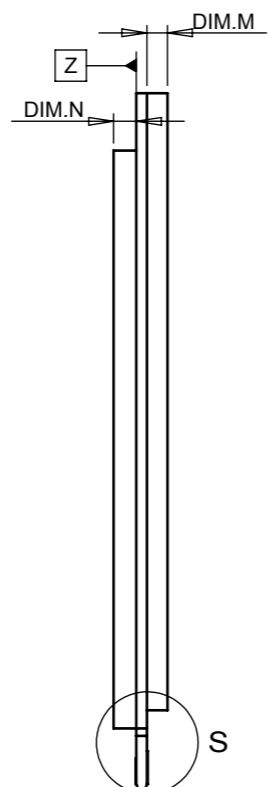
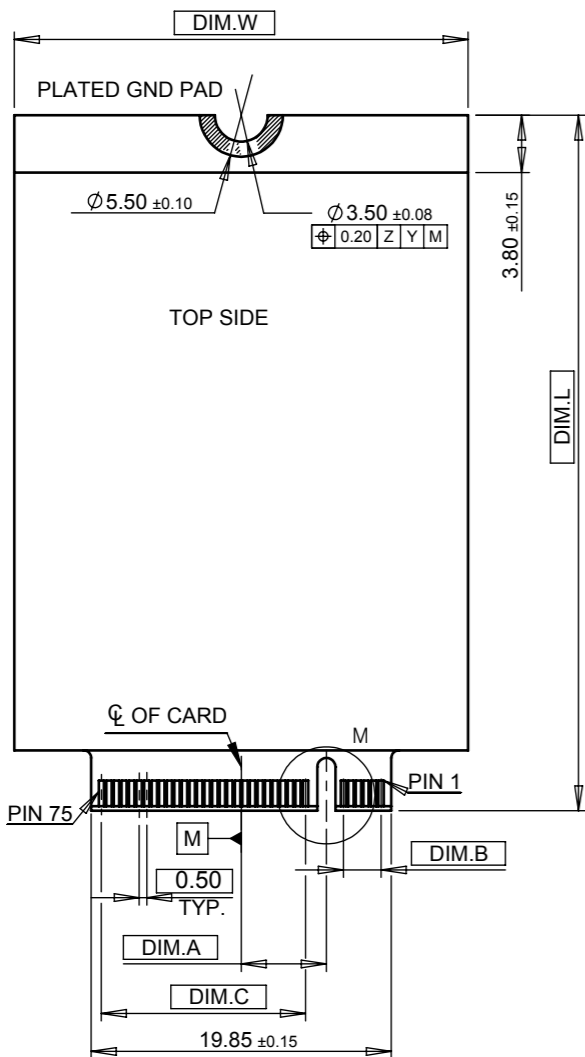

TYPE XX XX-XX-X

KEY ID

	COMPONENT MAX HEIGHT(mm)	
	DIM.N	DIM.M
S1	1.2	0
S2	1.35	0
S3	1.5	0
D1	1.2	1.35
D2	1.35	1.35
D3	1.5	1.35
D4	1.5	0.7
D5	1.5	1.5

LENGTH(mm)	30
DIM.L	42
	60
WIDTH(mm)	22
DIM.W	30

X. ± 0.15	X.° ±	UNITS mm	NAME(INTENDED USE) NGFF CONNECTOR	FOXCONN HON HAI PRECISION IND. CO.,LTD. TAIPEI, TAIWAN, R.O.C.
.XX ± 0.10	.XX° ±			
.XXX ± 0.05	.XXX° ±	FINISH	PART NO.(INTENDED USE) AS0BC2*-S40B*-7H	TITLE: CUSTOMER DRAWING
.XXX ±	.XXX° ±		Q'TY	APPD: C.S Li
THESE DRAWINGS AND SPECIFICATIONS ARE THE PROPERTY OF HON HAI PRECISION IND. CO., LTD. AND SHALL NOT BE REPRODUCED, COPIED OR USED IN ANY MANNER WITHOUT THE PRIOR WRITTEN CONSENT OF HON HAI PRECISION IND. CO., LTD.			CHKD: Alex Wang	SCALE SHEET REV. N/A 2/4 B
			DR: FL Liu 8/23'13	

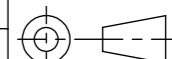

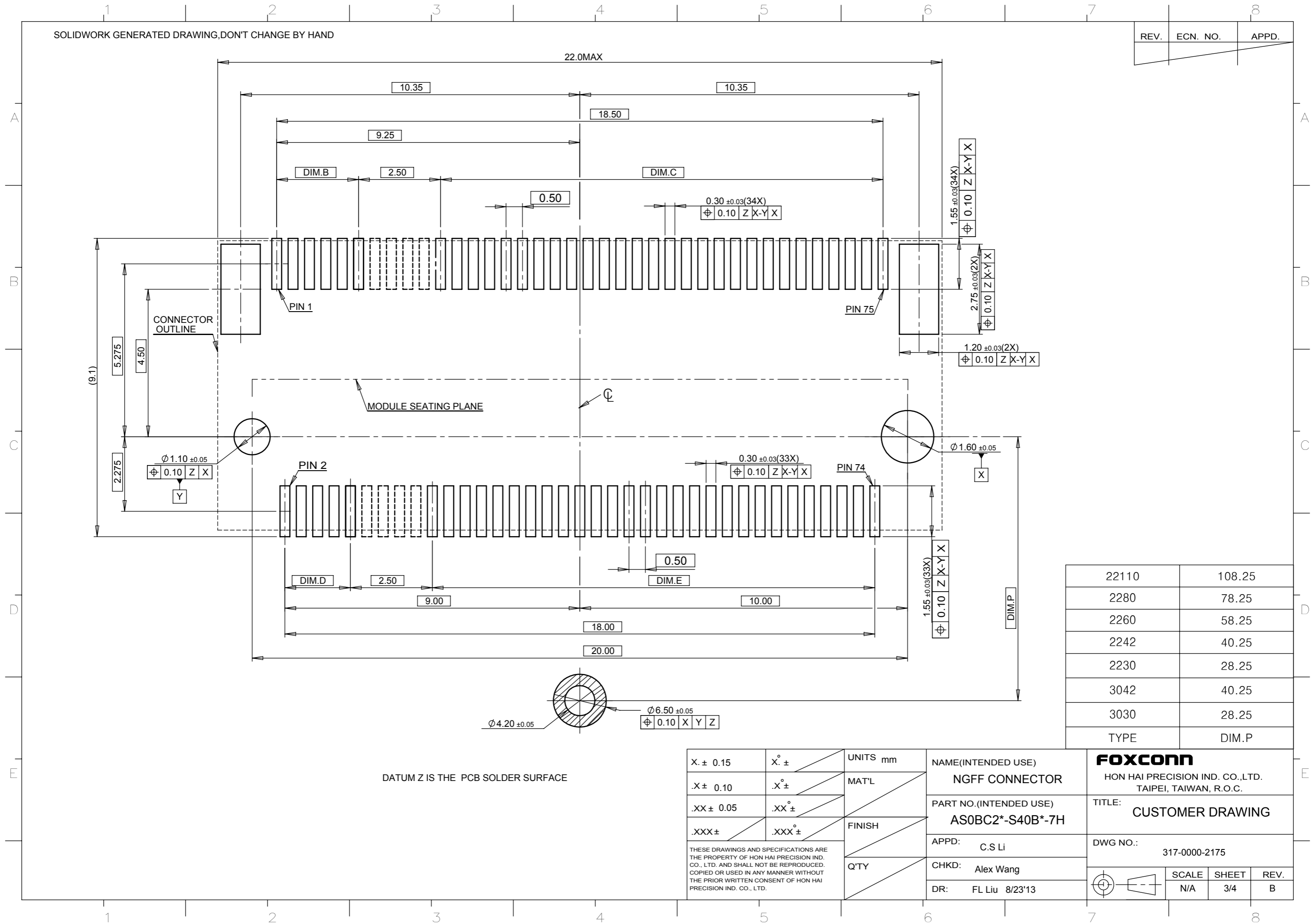

22110	108.25
2280	78.25
2260	58.25
2242	40.25
2230	28.25
3042	40.25
3030	28.25
TYPE	DIM.P

DATUM Z IS THE PCB SOLDER SURFACE

X. ± 0.15	X.° ±	UNITS mm	NAME(INTENDED USE)	FOXCONN HON HAI PRECISION IND. CO.,LTD. TAIPEI, TAIWAN, R.O.C.	
.X ± 0.10	.X° ±		NGFF CONNECTOR		
.XX ± 0.05	.XX° ±		PART NO.(INTENDED USE)		
.XXX ±	.XXX° ±		AS0BC2*-S40B*-7H		
THESE DRAWINGS AND SPECIFICATIONS ARE THE PROPERTY OF HON HAI PRECISION IND. CO., LTD. AND SHALL NOT BE REPRODUCED. COPIED OR USED IN ANY MANNER WITHOUT THE PRIOR WRITTEN CONSENT OF HON HAI PRECISION IND. CO., LTD.			APPD:	C.S Li	
			CHKD:	Alex Wang	
			DR:	FL Liu 8/23'13	
			TITLE: CUSTOMER DRAWING		
			DWG NO.: 317-0000-2175		
			SCALE	SHEET	REV.
			N/A	3/4	B

SOLIDWORK GENERATED DRAWING, DON'T CHANGE BY HAND

REV.	ECN. NO.	APPD.

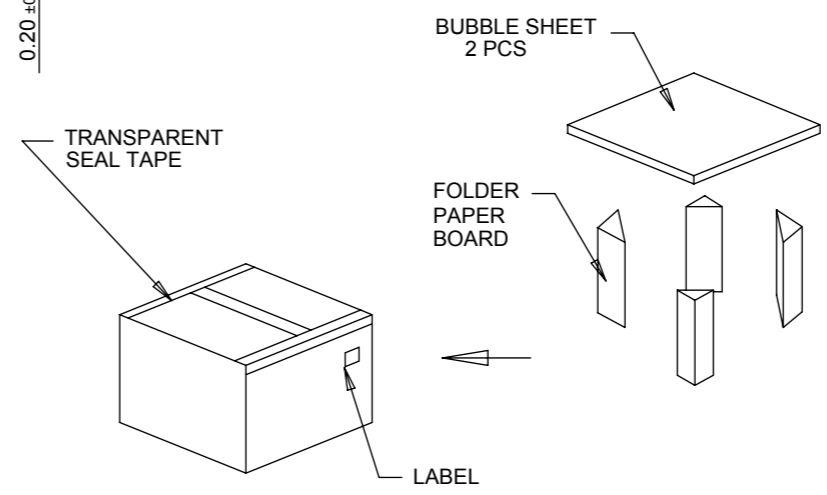
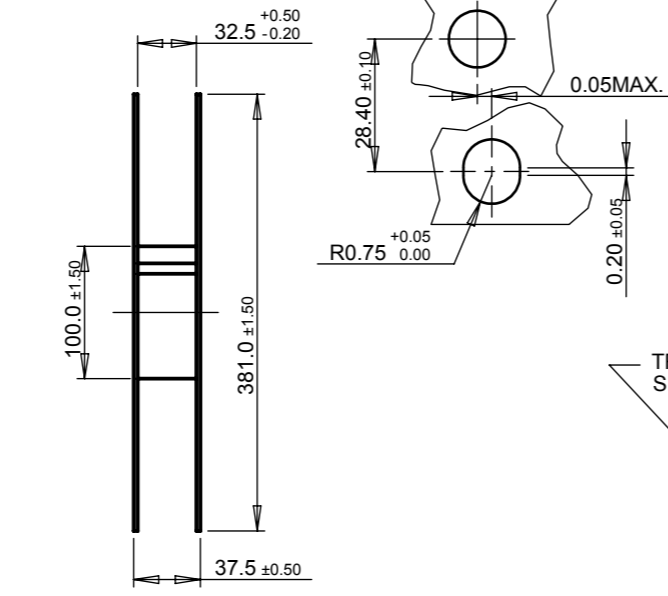
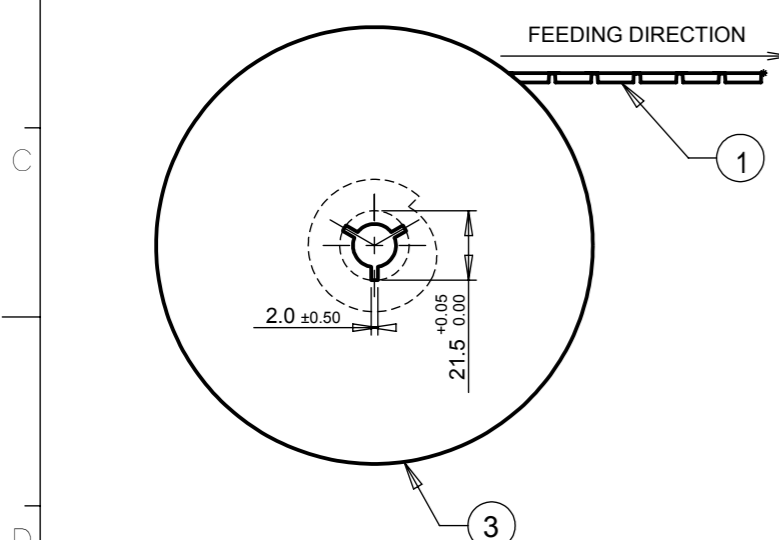
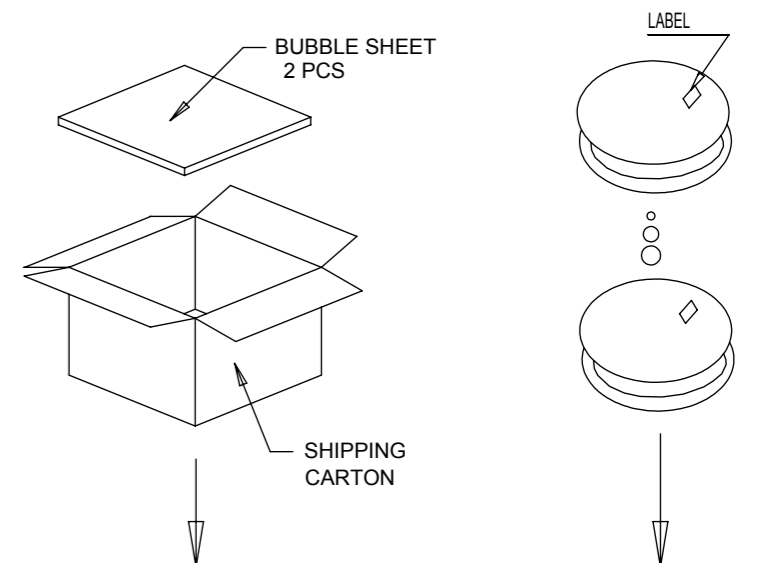
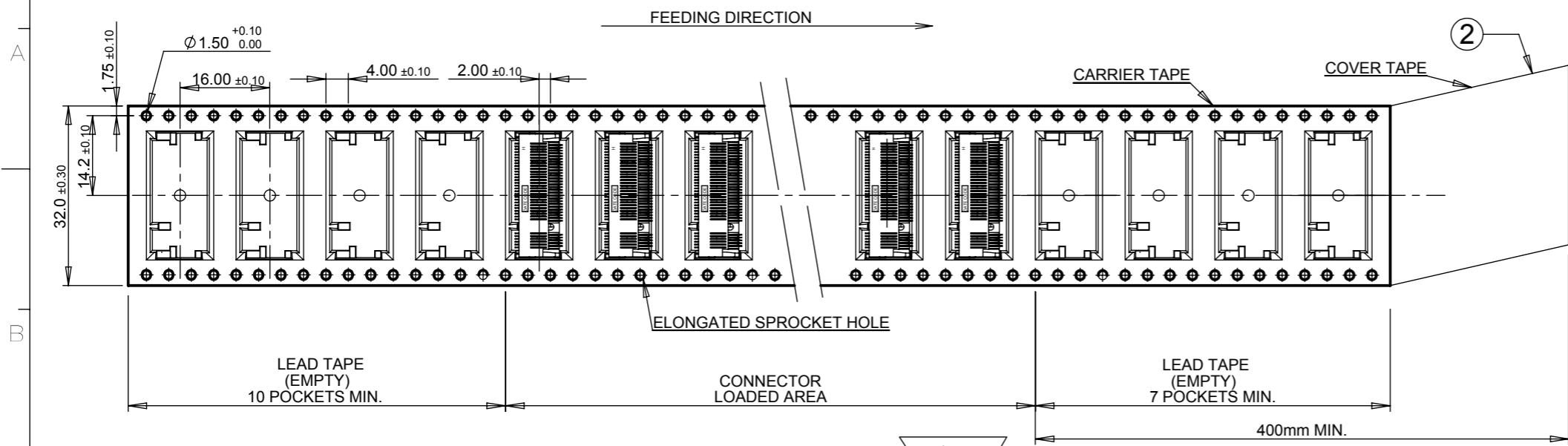

- NOTES:
- COVER TAPE PEELING STRENGTH : 0.01 kgf MIN & 0.13 kgf MAX. AT 300mm/min.
 - 10 POCKETS HOLE PITCH CUMULATIVE TOLERANCE $\pm 0.20\text{mm}$.

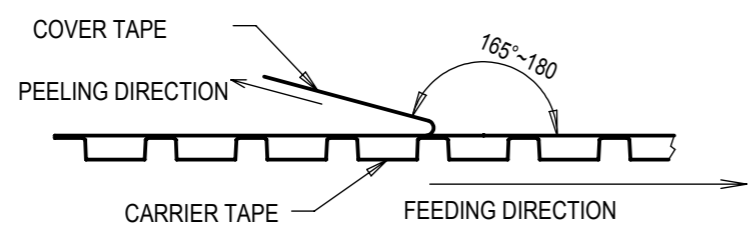

③	REEL	POLYSTYRENE
②	COVER TAPE	POLYESTER
①	CARRIER TAPE	POLYSTYRENE
ITEM	DESCRIPTION	MATERIAL

X. \pm 0.30	X. $^\circ$ \pm	UNITS mm	NAME (INTENDED USE) NGFF CONNECTOR	FOXCONN HON HAI PRECISION IND. CO., LTD. TAIPEI, TAIWAN, R.O.C.
.X \pm 0.25	.X $^\circ$ \pm	MAT'L	PART NO. (INTENDED USE) AS0BC2*-S40B*-7H	
.XX \pm 0.15	.XX $^\circ$ \pm	FINISH	APPD: C.S. Li	TITLE: CUSTOMER DRAWING
.XXX \pm	.XXX $^\circ$ \pm	Q'TY	CHKD: Alex Wang	DWG NO.: 317-0000-2175
THESE DRAWINGS AND SPECIFICATIONS ARE THE PROPERTY OF HON HAI PRECISION IND. CO., LTD. AND SHALL NOT BE REPRODUCED, COPIED OR USED IN ANY MANNER WITHOUT THE PRIOR WRITTEN CONSENT OF HON HAI PRECISION IND. CO., LTD.			DR: FL Liu 8/23'13	SCALE SHEET REV. N/A 4/4 B

AS0BC2*-S40B*-7H	940	7	6580
P/N	PCS/REEL	REEL/BOX	PCS/BOX