

EXTRACTION TOOL	ENHANCED SFP+ CAGE ASSEMBLY CONFIGURATION
2215058-1	1 X 1
2215058-2	1 X 2
2215058-3	1 X 3
2215058-4	1 X 4
2215058-5	1 X 5
2215058-6	1 X 6

Figure 1

## 1. INTRODUCTION

Enhanced SFP+ Extraction Tool Kits 2215058-[ ] are used to remove the printed circuit (pc) board from Enhanced SFP+ connector and cage assemblies described in Figure 1. The cage assemblies contain press-fit contacts. Read these instructions thoroughly before using the extraction tool kit.



### NOTE

Dimensions on this sheet are in metric units [with U.S. customary units in brackets]. Figures and illustrations are for reference only and are not drawn to scale.

## 2. DESCRIPTION

Each extraction tool kit consists of an extraction tool, a top push plate, base plate, and wall supports (one for each stacked row of the cage assembly).

The base plate features a finger mounting block that holds up to six wall supports to the base plate. See Figure 1. The top push plate is designed to be installed onto the upper tooling and the base plate is designed to be installed onto the lower tooling of the application tool. The extraction tool has cutouts (one located on each side) to accept the protruding part of the cage assembly. Each "finger" of a wall support fits into a port of the cage assembly.

During extraction, the back and sides of the extraction tool protect the cage assembly from damage, the wall supports support the individual ports of the cage assembly, and the top push plate provides a surface to apply an even force to extract the pc board from the connector and cage assembly.

### 3. APPLICATION TOOLING REQUIREMENT

Power for the extraction tool must be provided by application tools (with a ram) capable of supplying a downward force of 44.5 N [10 lb] per contact.

Manual Arbor Frame Assembly 58024-1 is available for use with these extraction tool kits. Refer to Instruction Sheet [408-6923](#) for operating procedure.



**CAUTION**

*Over-driving of the extraction tool could cause damage to the connector or cage assembly.*

### 4. EXTRACTION PROCEDURE

1. Ensure that the amount of wall supports installed onto the finger mounting block matches the amount of ports of the cage assembly. It is recommended to center the group of wall supports on the finger mounting block. Refer to Figure 1.
2. Install the top push plate onto the upper tooling and the base plate (with the wall supports) onto the lower tooling of the application tool. See Figure 2.



**CAUTION**

*Ensure that the upper tooling and lower tooling are secure; otherwise, damage to the connector and cage assembly could occur.*

3. Place the open end of the extraction tool over the cage assembly so that the cutouts align with the protruding part (at the back) of the cage assembly. Make sure that the sides of the extraction tool sit on the pc board.
4. Slide the extraction tool (with the connector and cage assembly and pc board) onto the wall supports so that each “finger” of each wall support enters a port of the cage assembly. Make sure the fingers are fully inserted into the ports. See Figure 2.

Side View

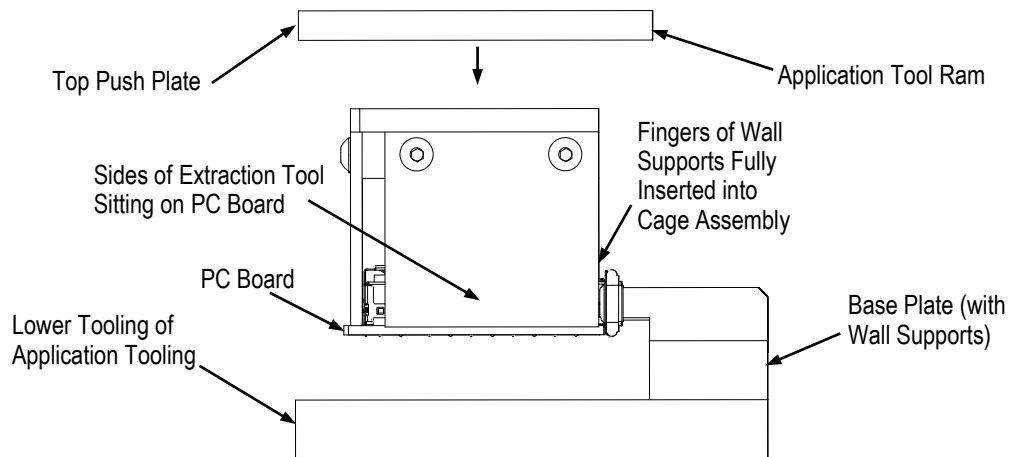

Figure 2

5. Cycle the application tool to extract the pc board from the connector and cage assembly. Then retract the ram, and carefully remove the extraction tool (with the connector and cage assembly) from the wall supports.

### 5. MAINTENANCE AND INSPECTION

The extraction tool kit is inspected before shipment. It is recommended that the extraction tool kit be inspected immediately upon arrival at your facility to ensure that it has not been damaged during shipment and that it conforms to the dimensions provided in Figure 3.

### 5.1. Daily Maintenance

It is recommended that each operator be made aware of, and responsible for, the following steps of daily maintenance:

1. Remove dust, moisture, and contaminants with a clean, soft brush or a lint-free cloth. DO NOT use objects that could damage the extraction tool kits components.
2. When the extraction tool kit is not in use, store it in a clean, dry area.

### 5.2. Periodic Inspection

Regular inspections should be performed by quality control personnel. A record of scheduled inspections should remain with the extraction tool kit or be supplied to personnel responsible for the extraction tool kit. Inspection frequency should be based on amount of use, working conditions, operator training and skill, and established standards.

## 6. REPLACEMENT AND REPAIR

Customer-replaceable parts are listed in Figure 3. A complete inventory should be stocked and controlled to prevent lost time when replacement of parts is necessary. Parts other than those listed should be replaced by TE Connectivity to ensure quality and reliability. Order replacement parts through your TE Representative, or call 1-800-526-5142, or send a facsimile of your purchase order to 717-986-7605, or write to:

CUSTOMER SERVICE (038-035)  
 TYCO ELECTRONICS CORPORATION  
 PO BOX 3608  
 HARRISBURG PA 17105-3608

## 7. REVISION SUMMARY

- Initial release of document

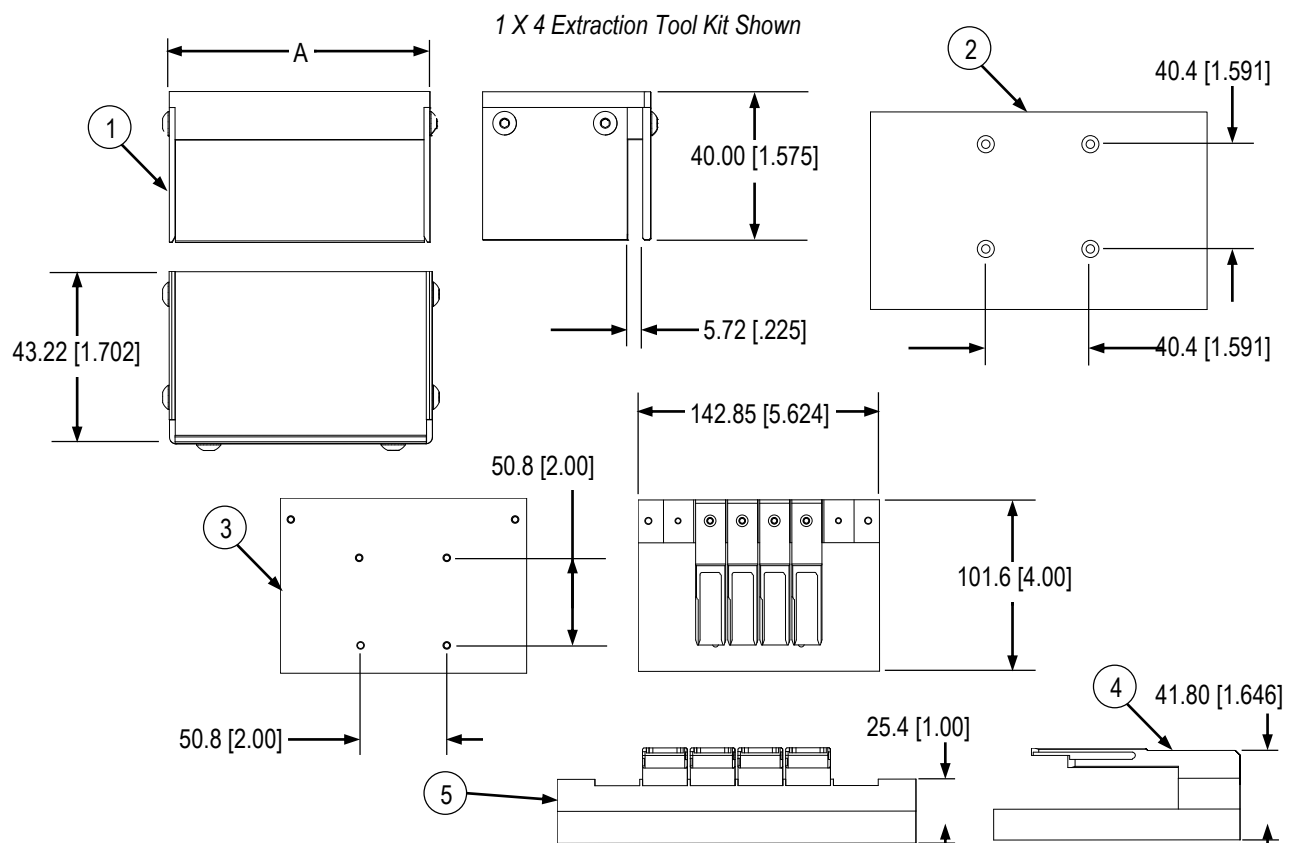

Figure 3 (cont'd)

TOOL (BY KIT PART NUMBER)	DIMENSION "A"
2215058-1	19.45 [.766]
2215058-2	33.70 [1.327]
2215058-3	47.95 [1.888]
2215058-4	62.20 [2.449]
2215058-5	76.45 [3.010]
2215058-6	90.70 [3.571]

ITEM NUMBER	DESCRIPTION	QTY PER TOOL					
		1 X 1	1 X 2	1 X 3	1 X 4	1 X 5	1 X 6
1	TOOL, Extraction	1	1	1	1	1	1
2	PLATE, Top Push	1	1	1	1	1	1
3	PLATE, Base	1	1	1	1	1	1
4	SUPPORT, Wall	1	2	3	4	5	6
5	MOUNTING BLOCK, Finger	1	1	1	1	1	1

ITEM NUMBER	EXTRACTION TOOL KIT PART NUMBER					
	2215058-1	2215058-2	2215058-3	2215058-4	2215058-5	2215058-6
1	2215059-1	2215059-2	2215059-3	2215059-4	2215059-5	2215059-6
2	211356-1					
3	2161354-1					
4	2215638-1					
5	2215637-1					

Figure 3 (end)