

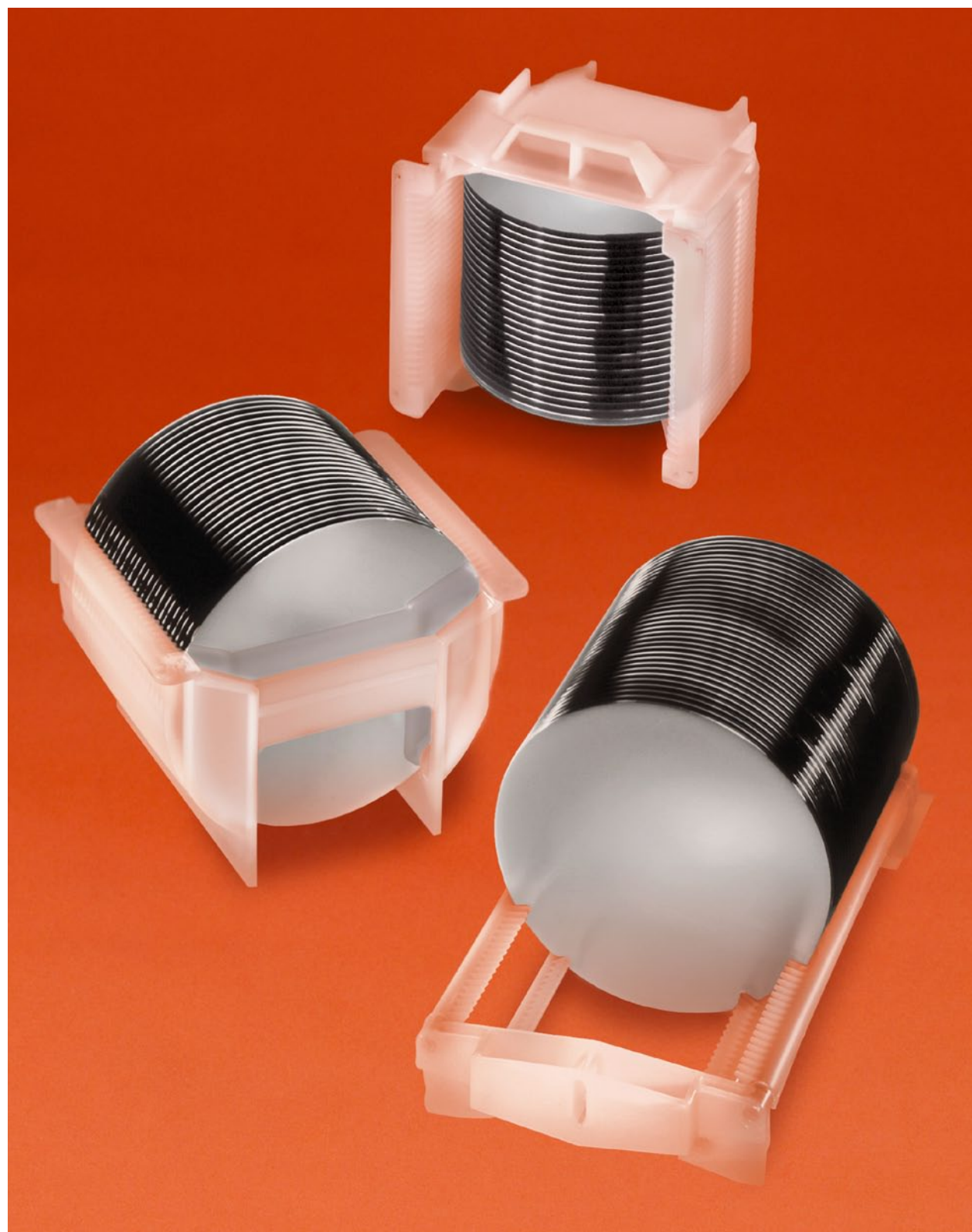

**200 MM PROCESS
WAFER CARRIERS**

For wet chemical processing applications



for wet chemical processing applications

Overview

Our traditional molded PFA process wafer carriers and modular construction PFA process enhancement wafer carriers are designed for wet chemical processing applications. The open flow carrier allows solutions to pass through evenly and quickly. They are also constructed of chemical-resistant PFA material so your processes remain uncontaminated.

Process Enhancement Wafer Carriers

Features

- One-half the volume and mass of traditional process carriers
- One-fourth the surface area of traditional process carriers
- Modular construction includes reinforcement rods for added rigidity and strength
- Lift points on carrier ends for automated handling
- V-notch locators on carrier ends and rails for location on equipment
- Wafer capacity: 50
- Pocket spacing: 6.4 mm (0.25")

Traditional Process Wafer Carriers

Features

- Low and high profile
- "H" bar for equipment interface
- Locating track notches at the center of the thirteenth pocket
- Pins and holes on the top rail (unless noted)
- Wafer capacity: 25, 26 or 50
- D1 dimension: 25.4 mm (1.00")
- Pocket spacing: A192-82M: 3.2 mm (0.13")
All others: 6.4 mm (0.25")
- Pocket flat: 1.7 mm (0.07")

Specifications

Materials:	PFA	
Temperature limits:	Continuous use (process enhancement)	165°C (329°F)
	Continuous use (traditional)	180°C (356°F)
	Wafer insertion	290°C (554°F)

Process Enhancement Wafer Carriers

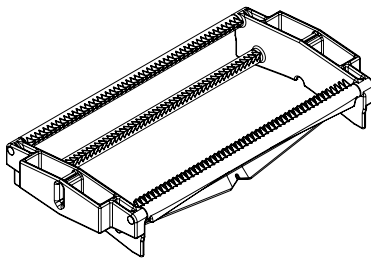

A220-200B50MP-0215

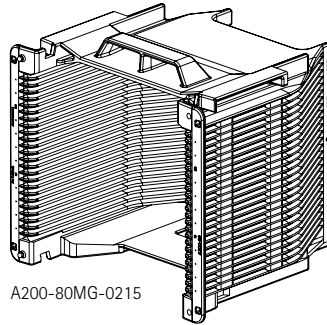

A200-80MG-0215

Traditional Process Wafer Carriers

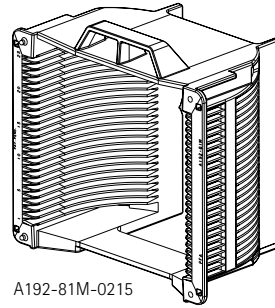

A192-81M-0215

Ordering Information

Process Enhancement Wafer Carriers

Part Number	Capacity	Automation Features	Compatible Boxes	Compatible Handles	Material	Notes
A220-200B50MP-0215	50	Lift points and V-notch locators on ends, V-notch locators on rails	None	None	Natural PFA	
A220-200B50P-0215	50	Lift points and V-notch locators on ends, V-notch locators on rails	None	None	Natural PFA	Rotated rail – contact Entegris

Traditional Process Wafer Carriers

Part Number	Capacity	End Wall Configuration	"H" bar End Flanges	Compatible Boxes	Compatible Handles	Material	Notes
A192-80M-0215	25	Handle, ¹ flanges ⁴	No	E99, E210, HA200	A057-2, A192-80-04	Natural PFA	High profile
A192-81M-0215	25	Handle, ¹ flanges ⁴	No	E99, E210, HA200	A057-1	Natural PFA	Low profile
A192-82M-0215	50	Handle, ² flanges ⁴	No	E99, E210, HA200	Contact Entegris	Natural PFA	Low profile
A200-80MG-0215	25	Handle, ² flanges ⁵	No	E210	A057-2	Natural PFA	High profile
A200-81M-0215	26	Flanges ⁴	No	E210	Contact Entegris	Natural PFA	High profile, no pins and holes

¹ Standard size, high position ² Large size, high position ³ Wide outboard ⁴ Standard outboard ⁵ C-style outboard

Handles

Entegris offers end-load and slingshot style handles molded of natural PFA material for use with traditional process wafer carriers.

End-load Style

To use, slip the handle down through the handle slot on the end wall of the carrier. Press the handle downward until the angled edges on the bottom of the handle are past the bottom of the solid end wall of the carrier, then pull up.

- Overall size: 465 mm × 71 mm × 27 mm (18.3" × 2.8" × 5.0")
- Part numbers:
 - A057-1-0215 for use with low profile carriers with handles
 - A057-2-0215 for use with high profile carriers with handles

Slingshot Style

To use, simply slip the grooves of the handle over the top flanges of the carrier.

- Overall size: 31 mm × 254 mm × 287 mm (1.2" × 10.0" × 11.3")
- Part number:
 - A192-80-04-0215 for high and low profile carriers with handle stops

Identification Options

Entegris offers a variety of identification options for carrier identification, including:

- Laser marking
- Ceramic encapsulated or PFA laminated PTFE bar coding
- Radio frequency tags
- Encapsulated alphanumeric tags

Contact Entegris to determine a suitable identification method for your application.



End-load style handle

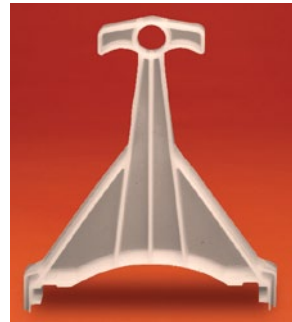

Slingshot style handle

For More Information

Please call your Regional Customer Service Center today to learn what Entegris can do for you. Visit www.entegris.com and select the Customer Service link for the center nearest you.

Terms and Conditions of Sale

All purchases are subject to Entegris' Terms and Conditions of Sale. To view and print this information, visit www.entegris.com and select the Legal Notices link from the footer.

Entegris® is a registered trademark of Entegris, Inc.

ENTEGRIS, INC.

Corporate Headquarters | 129 Concord Road | Billerica, MA 01821 USA
Customer Service Tel. +1 952 556 4181 | Customer Service Fax +1 952 556 8022
In North America 800 394 4083 | www.entegris.com