

Novel Current-Sense Measurement with Automatic Offset Correction Operates at 0.8 V and Runs on a Few MicroAmps and is Accurate to $\pm 1 \mu\text{A}$

1. Introduction

Pairing a simple circuit using nanopower analog op amps with a microcontroller can monitor single battery cells and solar harvesters. Pairing up a $0.65\text{V}/1\mu\text{A}$ nanopower op amp with the low-power Cypress PSoC3 microcontroller and some simple external circuitry can yield a very low current measurement system, suitable for monitoring miniature power harvesting solar cells or a single-cell battery. The circuit operates on a few microamps at 1.8V ; optionally, the whole circuit can be self-powered from the source being measured. The op amps operate from voltages as low as 0.65V and are connected directly to the cells; the PSoC3 microcontroller utilizes an internal boost regulator which operates from sources as low as 0.5V .

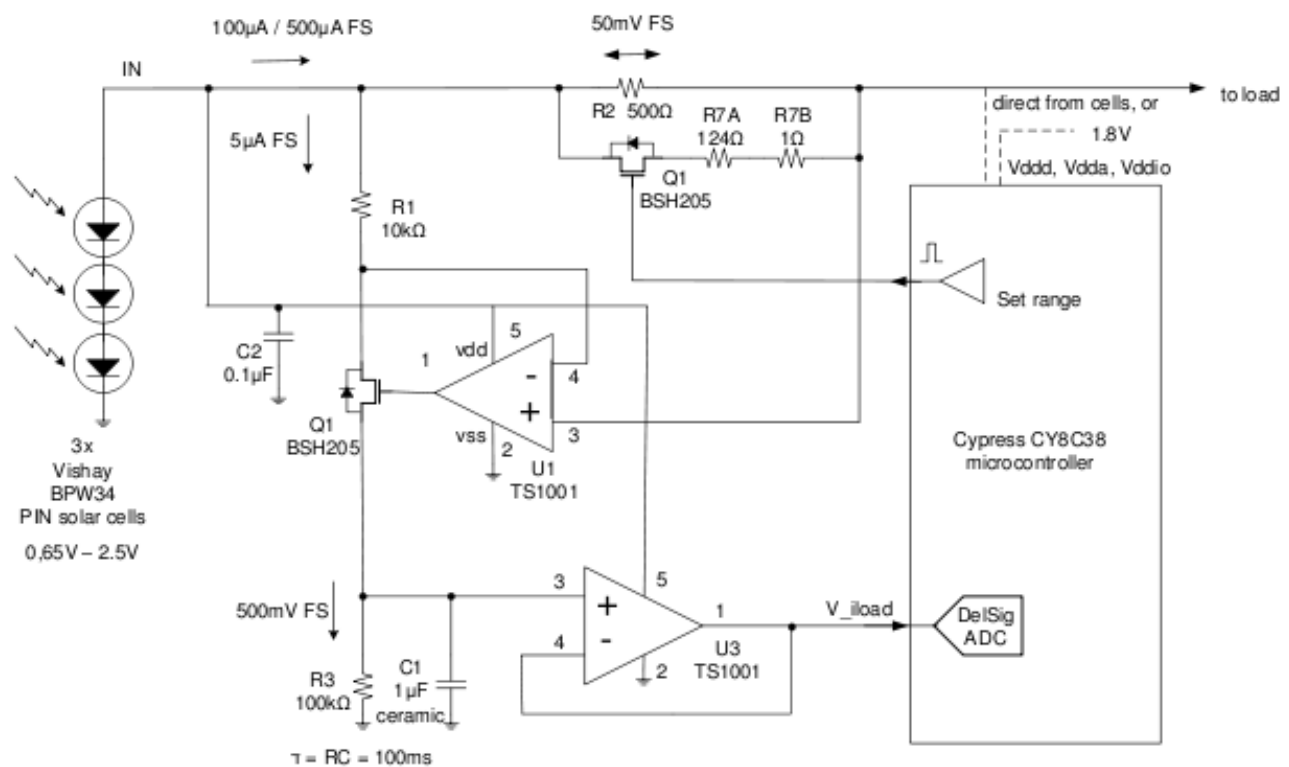

Figure 1. Current-Sense Amplifier with Input Offset Voltage Correction

The current sense amplifier is shown in Figure 1. The analog portion of the circuit operates from as low as 0.65V and draws 860nA at no load. The circuit provides a $0\text{-}500\text{mV}$ output for measured currents of $0\text{-}100\mu\text{A}$, though the scale can be adjusted by changing the values of a few resistors. With its extremely low power, the circuit can simply remain “always on,” providing a continuously monitored, averaged indication of current. The CY8C38 subsequently reads the value periodically, remaining in sleep mode and consuming less than $8\mu\text{A}$.

The analog circuit features the TS1001, a nanopower op amp capable of supply voltage operation to 0.65V configured to servo P-channel MOSFET Q1 in a current source configuration. The current source, draws current through R1 to compensate for the voltage drop across R2 caused by the current flow from the IN terminal to the load. Resistor R3 converts the current to a voltage and C1 provides filtering. The filtering is critical in allowing the current sense amplifier to continuously provide an averaged current output, enabling the microcontroller to sleep for long periods and save power, waking only periodically to read this mean current level.

Current used by Cypress CY8C38	Current used by the Current Sense Amplifier
8µA (average, polling)	860 nA

The accuracy of the circuit is extremely good and is generally limited only by the accuracy of the resistors used. 1% resistors yielded an error of no more than 1 µA.

Op amp input offset voltages need to be considered carefully in this circuit. The TS1001 op amp is specified with +/-3mV maximum input offset voltage at 25°C, which corresponds to +/-3mA of error. Another consideration is that Q1 exhibits drain-source leakage current of a few 10s of nanoamps at 25C, but this can approach 1µA over the commercial temperature range. Since the current through Q1 is effectively controlled by the op amp loop; therefore, any drain-source leakage from Q1 appears as a current floor and this generates a corresponding minimum voltage output across R3 below which current cannot be measured until the op amp “takes over” at higher measured currents. Therefore, normal methods of removing the current sense amplifier offset by subtracting the zero-load voltage at V_iloa will not work, since the offset voltage due to the op amp’s VOS and the current floor from Q1’s drain-source leakage cannot be separated.

Therefore, the offset correction scheme utilizing Q1 and R7 is implemented. Amplifier input offset voltage may be calibrated out using the principal of making two measurements of the same parameter at the two gain settings. The offset voltage then can be found as:

$$V_{OFFSET} = V_{ILOAD_G2} * \frac{R_{G1}}{R_{G1} - R_{G2}} - V_{ILOAD_G1} * \frac{R_{G2}}{R_{G1} - R_{G2}}$$

where Viloa_G1 and Viloa_G2 are the measurements made with low range and high range mode, respectively, and where:

$$R_{G1} = R_2$$

$$R_{G2} = \frac{R_2 R_7}{R_2 + R_7}$$

In this case, RG1 = 500 and RG2 = 100, effectively providing two scales of 100 µA and 500 µA full scale, respectively. The CY8C38 Microcontroller Code for Offset-Voltage-Corrected Current-Sense Amplifier follows:

```

/*****
* File Name: main.c
*
* Version: 1.0
*
* Description:
* This is source code for the Current Sense Amplifier
*
*****/
#include
#include

/*****
* Function Name: main
*****/
* Target Device:
* CY8C38 processor
*****/
void main()
{
    int32 ADCResult;
    float Iin;
    float Iin_corrected;
    char OutputString[32];

```

```

float Offset;
int16 Offsetcounter;
Offsetcounter= (int16) 0;
Offset= (float) 0;
LED_P1_2_Write(0xFFu); // Indicates active mode. Remove LED for Icc.
GAINSWITCH_P1_6_Write(0xFFu); // GAINSWITCH to mode 1
CYGlobalIntEnable; // global interrupts
//LCD_Start(); // start components (LCD optional)
isr_Start();
ADC_Start();
SleepTimer_Start(); // sleep timer params set in the GUI
for(;;)
{
    ADC_StartConvert(); // make a conversion and
wait
    while (ADC_IsEndConversion(ADC_RETURN_STATUS) == 0)
    {
        ADCResult = ADC_CountsTo_mVolts(ADC_GetResult32()); // math
        Iin= (float) ADCResult/5 ; // units microamps
        Iin_corrected= (float) Iin - Offset;
        // Optional LCD display
        /*
        sprintf(OutputString, "%5.3f",Iin_corrected); // 300usecs
        LCD_Position(0,0); // write to L
CD; 700usecs
        LCD_PrintString("I load=");
        LCD_Position(0,8);
        LCD_PrintString(OutputString);
        */
        ADC_StopConvert();
        if (Offsetcounter==32)
        {
            if ((Iin> 50) && (Iin<100))
            {
ode 2
                GAINSWITCH_P1_6_Write(0x00u); // switch gain to m
                CyDelay(50u); // delay
                ADC_StartConvert(); // make a conversio
n and wait
                while (ADC_IsEndConversion(ADC_RETURN_STATUS) == 0)
                {
                    ADCResult = ADC_CountsTo_mVolts(ADC_GetResult32());
                    Offset= (float) ADCResult/5*1.25 - Iin*0.25;
                    // Optional LCD display
                    /*
                    LCD_Position(1,0);
                    LCD_PrintString("Offset= ");
                    sprintf(OutputString, "%5.3f",Offset);
                    LCD_Position(1,8);
                    LCD_PrintString(OutputString);
                    */
                    Offsetcounter= (int16) 0;
                    ADC_StopConvert();
                    GAINSWITCH_P1_6_Write(0xFFu); // switch gain to m
ode 1
                }
            }
            else
            {
                }
            }
            else
                Offsetcounter= (int16) Offsetcounter+1;
            ADC_Sleep();
            LED_P1_2_Write(0x00u); // LED off for sleep mode.
            CyPmSaveClocks(); // sleep mode
            CyPmSleep(PM_SLEEP_TIME_NONE, PM_SLEEP_SRC_CTW);
            CyPmReadStatus(CY_PM_CTW_INT);
            CyPmRestoreClocks(); // wake up
            ADC_Wakeup();
        }
    }
}
/* [] END OF FILE */

```

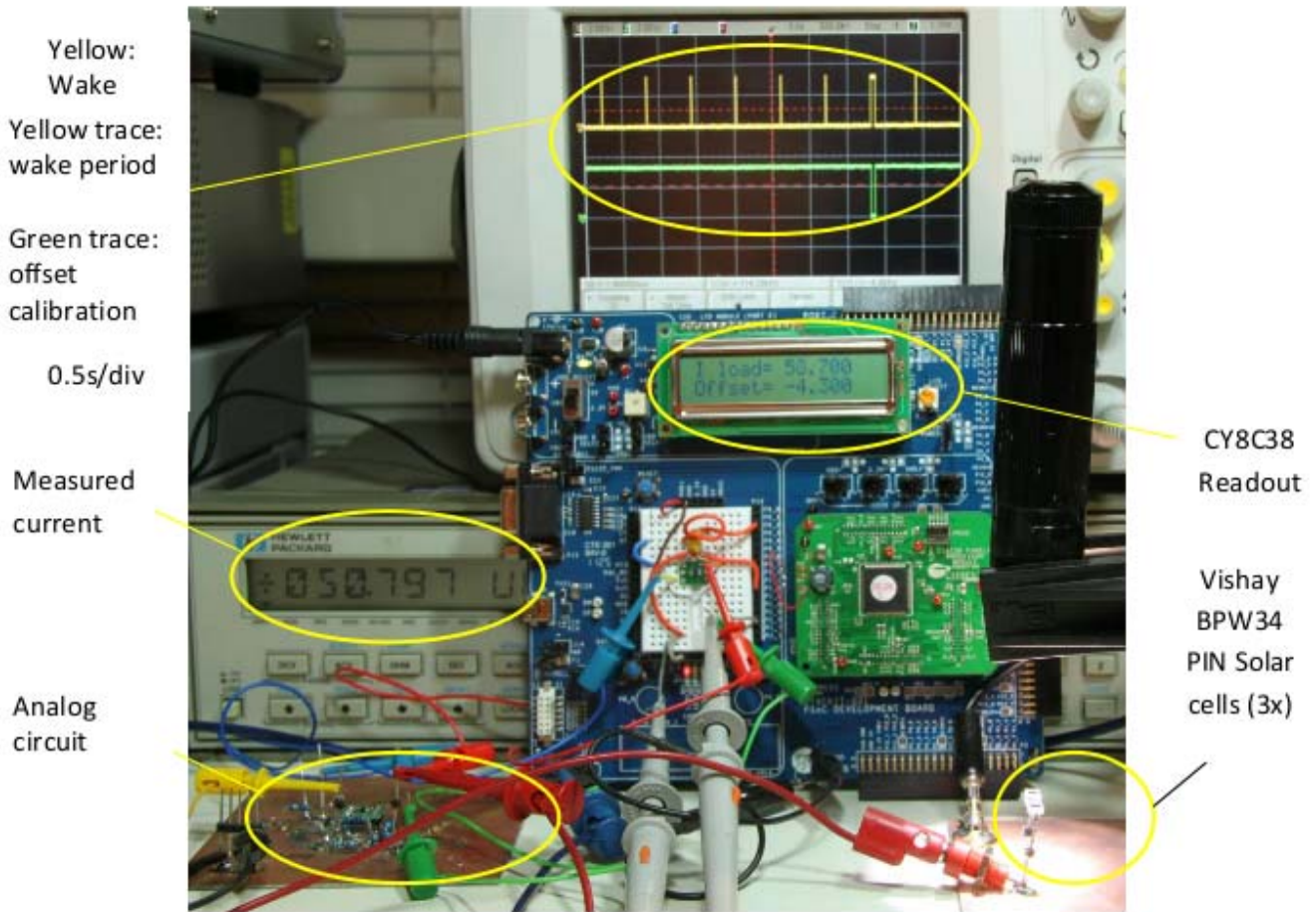

Figure 2. Lab Setup for Offset-Voltage-Corrected Current-Sense Amplifier using the TS1001 and the CY8C38 PSoC3 Microcontroller

Figure 2 shows the lab setup. The measured current is shown to match accurately the current estimated by the current sense measurement system. The oscilloscope shows wake periods approximately every 600 msec, with the offset cal period shown by the green trace (the gate voltage of Q1).

See the documentation for the TS1001 Op Amp and CY8C38 PSoC3 Microcontroller. For additional information, contact Silicon Labs.

CONTACT INFORMATION

Silicon Laboratories Inc.

400 West Cesar Chavez
Austin, TX 78701
Tel: 1+(512) 416-8500
Fax: 1+(512) 416-9669
Toll Free: 1+(877) 444-3032

Please visit the Silicon Labs Technical Support web page:
<https://www.siliconlabs.com/support/pages/contacttechnicalsupport.aspx>
and register to submit a technical support request.

Patent Notice

Silicon Labs invests in research and development to help our customers differentiate in the market with innovative low-power, small size, analog-intensive mixed-signal solutions. Silicon Labs' extensive patent portfolio is a testament to our unique approach and world-class engineering team.

The information in this document is believed to be accurate in all respects at the time of publication but is subject to change without notice. Silicon Laboratories assumes no responsibility for errors and omissions, and disclaims responsibility for any consequences resulting from the use of information included herein. Additionally, Silicon Laboratories assumes no responsibility for the functioning of undescribed features or parameters. Silicon Laboratories reserves the right to make changes without further notice. Silicon Laboratories makes no warranty, representation or guarantee regarding the suitability of its products for any particular purpose, nor does Silicon Laboratories assume any liability arising out of the application or use of any product or circuit, and specifically disclaims any and all liability, including without limitation consequential or incidental damages. Silicon Laboratories products are not designed, intended, or authorized for use in applications intended to support or sustain life, or for any other application in which the failure of the Silicon Laboratories product could create a situation where personal injury or death may occur. Should Buyer purchase or use Silicon Laboratories products for any such unintended or unauthorized application, Buyer shall indemnify and hold Silicon Laboratories harmless against all claims and damages.

Silicon Laboratories and Silicon Labs are trademarks of Silicon Laboratories Inc.
Other products or brandnames mentioned herein are trademarks or registered trademarks of their respective holders.