



FHH SX-U1

1000W Power Supply



FEATURES:

- Power factor 115Vac=0.99 230Vac=0.99
- Harmonics acc. to EN 60555-2 IEC1000-3-2 3. N+1 Redundant
- Parallel operation
- EMI:complies with EN 55022 B, FCC class B
- Safety: complies with to IEC 950 (approvals pending)



MODEL/CHANNEL		Unit	FHH-3.3SX-U1	FHH-5SX-U1	FHH-6SX-U1	FHH-12SX-U1	FHH-15SX-U1
OUTPUT	Norminal Voltage	V	3.3	5	6	12	15
	Current	A	200	200	167	88	70
	Efficiency	%	68	76	78	82	81
MODEL/CHANNEL		Unit	FHH-24SX-U1	FHH-30SX-U1	FHH-36SX-U1	FHH-48SX-U1	
OUTPUT	Norminal Voltage	V	24	30	36	48	
	Current	A	44	35	29	22	
	Efficiency	%	83	83	83	83	
	Input Regulation	mV	0.5%MAX				
	Load Regulations	mV	1%MAX				
	Temperature Coefficient	mV	0.03%/°C				
	Adjustable Voltage	-	± 10%, typical				
	Drift/Time Effect	mV	(Output V X 0.5%)+15mV/8H (After 1Hr)				
	Ripple & Noise Max.	mV	(Output V x 1%) + 100mVp-p MAX.				
	Rise Up Time	ms	500mS typ. @ 115 VAC in/ 250mS typ. @230 VAC in				
	Hold-up Time Typ.	ms	20mS MIN (at 25°C,Rated-Input-Output)				





FHH SX-U1

1000W Power Supply

	MODEL/CHANNEL	Unit	
INPUT	Current	A	16A / 8A(Input 115V/230VAC)
	Power factor	-	Active filter circuit with boost converter, 85~255VAC
	Voltage, Frequency	V	115~230VAC; 85~264VAC; 50/60Hz
	Inrush Current	A	18A MAX.(Input 115VAC), 36A MAX. (Input 230VAC)
	Leakage Current	mA	AC 115VAC, 50Hz, AC 230VAC, 50Hz, 25°C 550A
FUNCTION	Over Voltage Protection	V	Constant current limiting
	Over Current Protection	A	Output shutdown
	Switching Frequency	-	130KHz Fixed
ELECTRICAL ISOLATION	(1) Input - Output	-	(Input-Output) :AC3000V(1Minute)
	(2) Input - F.G	-	(Input-Chassis) AC2500V (1Minute)
	(3) Output - F.G	-	(Output-Chassis) AC 500V (1Minute)
	Insulation Resistance	-	(Input-Output-Chassis):50M MIN.
Environment	Operating temp. & Humidity	-	-5 ~+50°C (See output derating curve)
	Storage temp. & Humidity	-	-20~+85°C/85%
	Vibration	-	(5~10Hz) Amplitude (peak to peak) 10mm(constant) (10~55Hz) Acceleraton 2G (constant) X, Y, Z
	Shock	-	30G
	Safety	-	EN 60950-1, UL 1950, CSA 234.
	Power Factor	-	EN 60555-2, EN 55022 B, FCC level B
Dimension	Size(LxWxH)/Weight	mm/g	163x250x93/3900g





Block Diagram

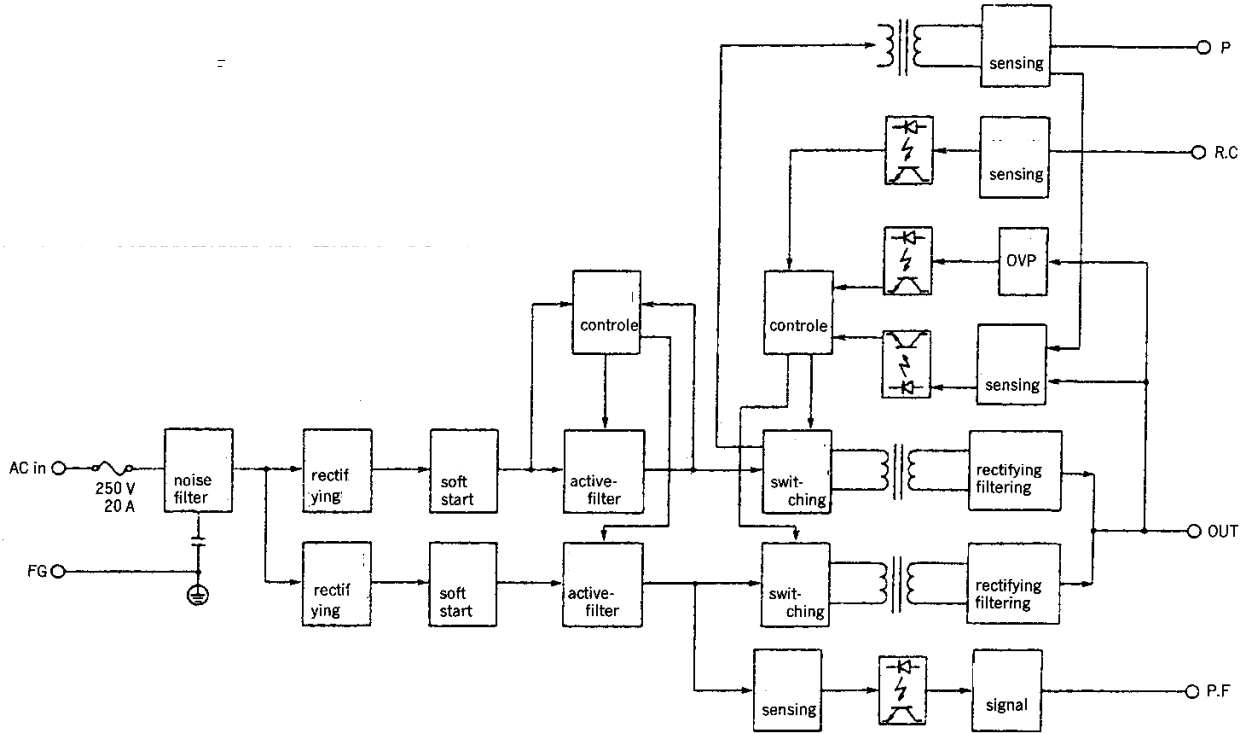

Terminal Connection

NO		7	F G
1	R. C	8	AC in (N)
2	R C G	9	AC in (L)
3	P		
4	P. F		
5	- S		
6	+ S		





Load and Output

