

## Remote I/O R3 Series

### PULSE OUTPUT MODULE

(open collector output, 16 points)

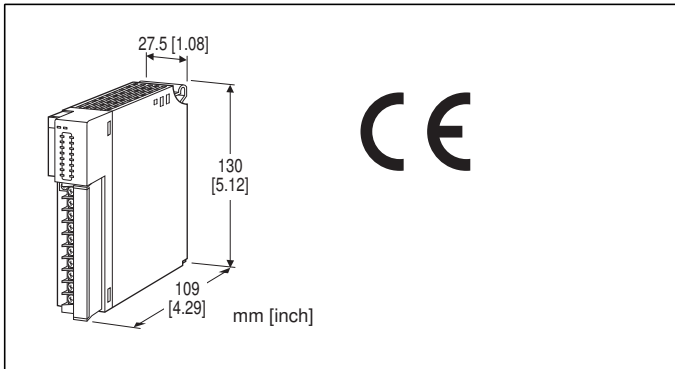

### MODEL: R3-PC16A[1][2]

#### ORDERING INFORMATION

- Code number: R3-PC16A[1][2]
- Specify a code from below for each of [1] and [2].  
(e.g. R3-PC16AW/CE/Q)
- Specify the specification for option code /Q  
(e.g. /C01)

#### NO. OF CHANNELS

16: 16

#### OUTPUT

A: Open collector

#### [1] COMMUNICATION MODE

S: Single

W: Dual

#### [2] OPTIONS (multiple selections)

##### Standards & Approvals

blank: Without CE

/CE: CE marking

##### Other Options

blank: none

/Q: Option other than the above (specify the specification)

#### SPECIFICATIONS OF OPTION: Q

**COATING (For the detail, refer to M-System's web site.)**

/C01: Silicone coating

/C02: Polyurethane coating

/C03: Rubber coating

#### GENERAL SPECIFICATIONS

##### Connection

**Internal bus:** Via the Installation Base (model: R3-BSx)

**Output:** M3 separable screw terminal (torque 0.5 N·m)

**Internal power:** Via the Installation Base (model: R3-BSx)

**Screw terminal:** Nickel-plated steel

**Isolation:** Output to internal bus or internal power

**RUN indicator:** Bi-color (red/green) LED;

Red when the bus A operates normally;

Green when the bus B operates normally;

Amber when both buses operate normally.

**ERR indicator:** Bi-color (red/green) LED;

Red with external power supply abnormality;

Green in normal operating conditions.

**Output status indicator:** Red LED; turns on with the output ON.

**Pulse width adjustment:** Side DIP SW

#### OUTPUT SPECIFICATIONS

**Output:** Open collector, 16 points

**Max. frequency:** 100 Hz (selectable with DIP SW)

**Max. output pulse number per setting:** 2000

(No output when a number greater than 2000 is set.)

**Totalized pulse range:** 1 - 10000 ('0' at reset only)

Max. pulse range selectable from 1 to 65535 using the R3CON PC Configurator Software. Refer to the R3CON Users Manual for detailed information.

**Count at overflow:** Reset and restart at '1.'

**Rated load voltage:** 24 V DC  $\pm 10\%$

**Maximum load current:** 0.1 A per point

**Maximum rush current:** 0.5 A for max. 10 msec.

**Maximum leak current at OFF:** 0.1 mA

**Maximum voltage drop at ON:** 0.1 V DC typical; 1.2 V DC max.

**Common:** All 16 points (2 terminals)

**Common current:** Max. 1.6 A per common

**External power supply:** 24 V DC  $\pm 10\%$  approx. 0.02 A

#### INSTALLATION

**Operating temperature:** -10 to +55°C (14 to 131°F)

**Operating humidity:** 30 to 90 %RH (non-condensing)

**Atmosphere:** No corrosive gas or heavy dust

**Mounting:** Installation Base (model: R3-BSx)

**Weight:** 200 g (0.44 lb)

#### PERFORMANCE

**Data allocation:** 16

**Current consumption:** Approx. 100 mA

**Insulation resistance:**  $\geq 100\text{ M}\Omega$  with 500 V DC

**Dielectric strength:** 2000 V AC @ 1 minute

(output to internal bus or internal power)

2000 V AC @ 1 minute (power input to FG; isolated on the power supply module)

## STANDARDS & APPROVALS

### EU conformity:

EMC Directive

EMI EN 61000-6-4

EMS EN 61000-6-2

RoHS Directive

## FUNCTIONS

### MANUAL COUNT RESET

- 1) Remove Network Module or its cables and interrupt communication with other devices.
- 2) Turn ON the Count Reset SW (SW3-1).
- 3) Return the module to the base and turn the power supply on.
- 4) ERR LED turns on and the module starts resetting its counter. When the resetting is complete, the LED turns to green. DO NOT remove the power while the red LED is on. The RUN LED starts blinking at the same time.
- 5) After the green LED is confirmed, turn the power supply off.
- 6) Turn OFF the Count Reset SW (SW3-1).
- 7) Return the Network module onto the base and turn the power supply on.

Note: Count Reset SW must be turned OFF after this procedure because the module does not start counting with ON state.

## EXTERNAL VIEW

### FRONT VIEW

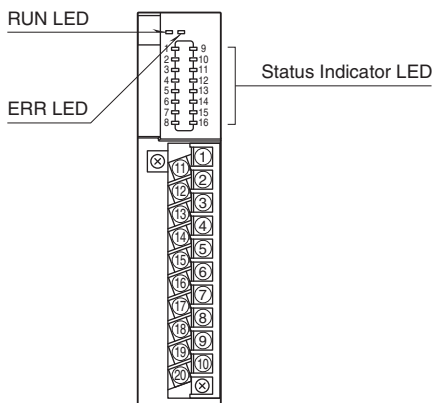

### SIDE VIEW

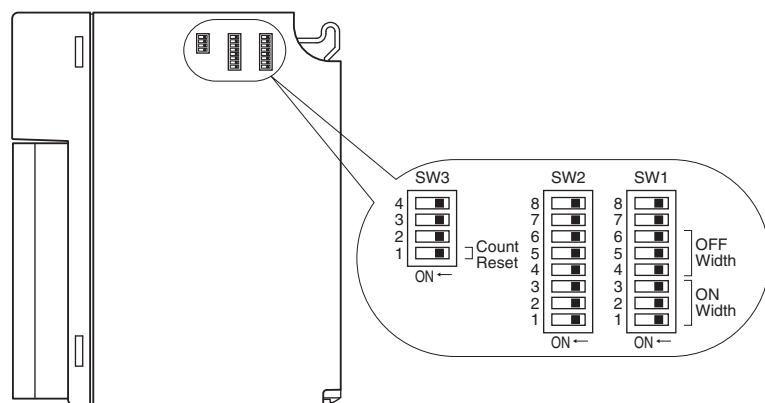

Count Reset SW must be turned off during operation.

## EXTERNAL DIMENSIONS & TERMINAL ASSIGNMENTS unit: mm [inch]

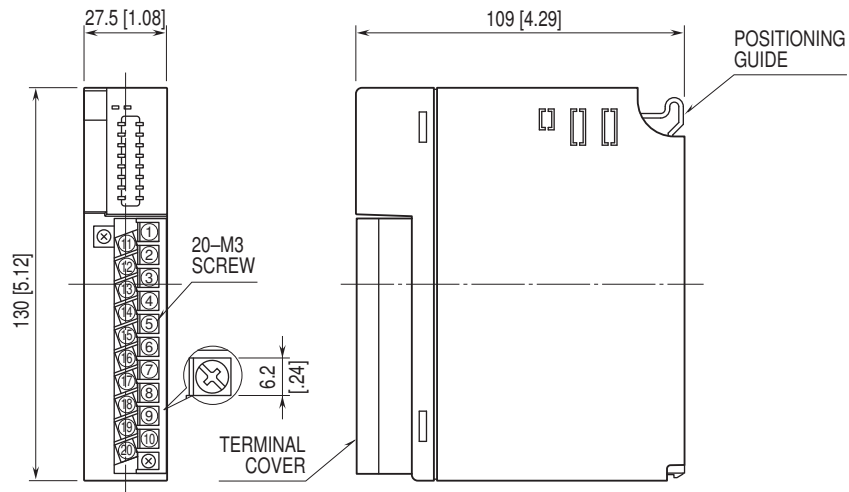

## SCHEMATIC CIRCUITRY & CONNECTION DIAGRAM

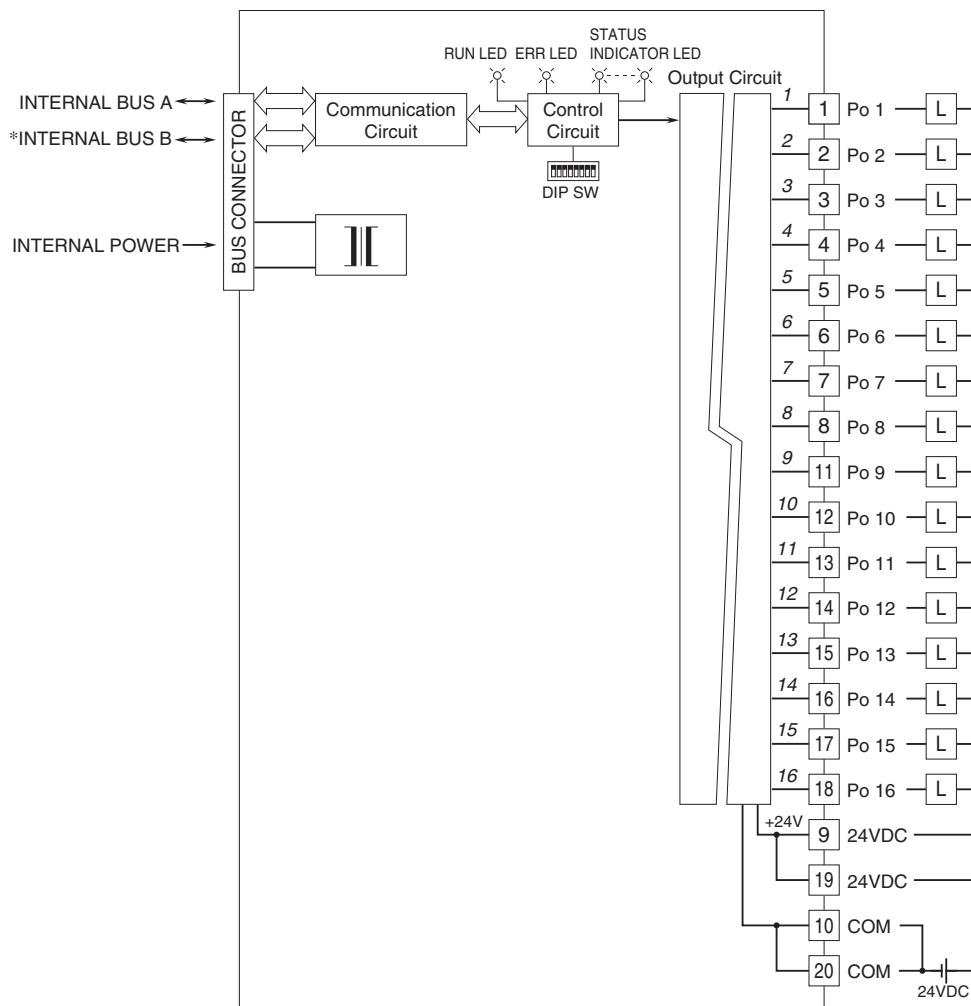

Numbers in italic indicate LED No.s assigned to the front panel LEDs.  
 \* For dual redundant communication.



Specifications are subject to change without notice.