



## RLTMLL-671 3-5W

LOW NOISE LASER



## Green Diode Pumped Solid State Laser

All solid state 671 nm low noise laser featuring of compact size, long lifetime, and low cost, which is widely used for DNA sequencing, flow cytometry, cell sorting, chip inspection, holograpy, spectrum analysis, etc.



Specifications	
Wavelength	671 ±1 nm
Output Power	3 - 5 W
Transverse Mode	Near TEM <sub>00</sub>
Operating Mode	CW
Power Stability (rms, over 4 hours)	< 1%, < 3%, < 5%
Warm-up time	< 15 min
M <sup>2</sup> factor	< 3.0 – 6.0
Beam Divergence (full angle)	< 2.0 mrad
Beam Diameter (at the aperture)	~ 4.0 mm
Beam Height (from base plate)	93.5 mm
Polarization ratio	> 100:1
<b>Noise of amplitude (rms, 1 - 20Mhz)</b>	<b>&lt; 1%</b>
Operating Temperature	10 - 35 °C
Power Supply (90-260VAC)	PSU-FDA (included)
Expected Lifetime	10000 hours
<b>Warranty period</b>	<b>1 year</b>

Options	
Fiber coupling	Multi mode/single mode fiber, SMA-905/FC connector



**LASER RADIATION**  
AVOID DIRECT EXPOSURE TO BEAM  
**DO NOT STARE INTO BEAM**  
NEVER VIEW THROUGH OPTICAL INSTRUMENTS



## RLTMLL laser head



333 x 140 x 125 mm<sup>3</sup>, 6.1 kg

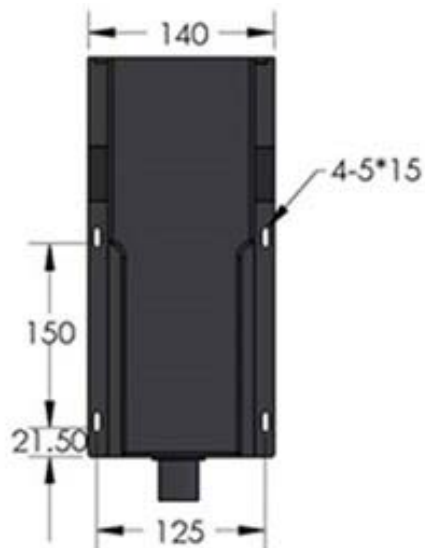

All dimensions in mm

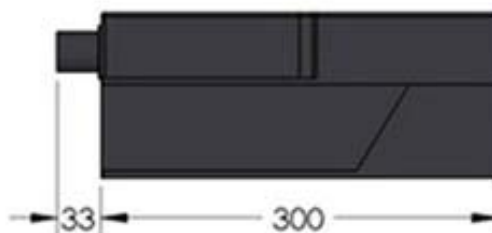
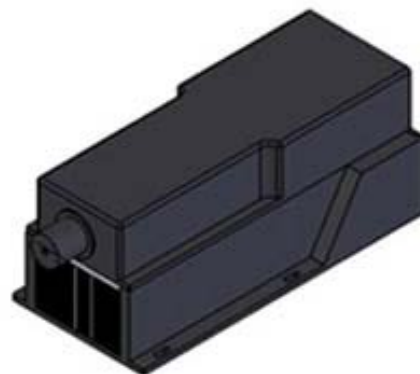



## PSU-FDA power supply



307 x 168 x 123 mm<sup>3</sup>, 5.1 kg

